

VARVEL[®]
MOTION CONTROL SINCE 1955

technology made in Italy



RD



* VS made in China

Technology Made in Italy

Since 1955 Varvel has been making speed reducers and variators for light industry applications. Reliable partner in power transmission equipment offers also customized solutions always according to a socially responsible company values. Modularity and flexibility lead Varvel products by a unique kit form, common to all gearbox series. This feature allows distributors an easier job to set up required products in few minutes.



Helical Gearboxes

RD



Helical Gearboxes RD

PRODUCT DESCRIPTION

Housing & Covers
Aluminium die cast (5 sizes)
Cast iron (2 sizes)

Gearing
20MnCr5 alloy steel
Case hardened
Profile ground or shaved

Bearings
Ball or roller types
according to sizes
and technical requirements

Multipurpose housing
Foot & Foot/Flange Mountings
One housing for 2- & 3-stages



Lubrication
Synthetic long-life oil Grade ISO VG 320
No oil plugs
In-house filling

Input
NEMA and IEC
motor adapters and
Universal elastic coupling

Oil seals
Nitrile Butadiene Rubber -NBR
as standard;
Viton and Silicon on request

Output
Solid shafts
imperial and metric

CONTENTS

Product Description	2-3	Dimensions	
Symbols & Formulas.....	3	RD 02 - 03	26-27
Modular System	4-5	RD 12 - 13	28-29
Elastic Coupling "G"	6	RD 22 - 23	30-31
Elastic Coupling "G" Selection	7	RD 32 - 33	32-33
NEMA Flanges and Elastic Couplings	8	RD 42 - 43	34-35
IEC Flanges and Elastic Couplings	9	RD 52 - 53	36-37
Electronic Catalogue - 3D-Models - 2D-Drawings	10	RD 62 - 63	38-39
Order Designation.....	11	Summary of "Operation and Manual Instructions".....	40
Input Arrangements	12		
Mounting Positions	13		
Service Factors	14-16		
External Loads	17		
Components & Conversion Factors	18		
Ratings			
RD 02 - 03	19		
RD 12 - 13	20		
RD 22 - 23	21		
RD 32 - 33	22		
RD 42 - 43	23		
RD 52 - 53	24		
RD 62 - 63	25		

Helical Gearboxes RD

PRODUCT DESCRIPTION

The helical gearboxes Series RD feature a one-piece cast housing complete with inner support to accommodate 2 or 3 gear stages into the same casing. Manufactured to latest ISO engineering design specifications the housing is checked by computer-aided structural analysis for deflection and stress distribution.

Significant strains caused by the effects of torque and external loads do not deflect the monolithic ribwork of the housing, which significantly improves the integrity of the sealed surfaces.

The helical gearboxes, Series RD are manufactured in B3 base mounted configuration; they can be easily converted to B5 flange mounting by fitting of the appropriate additional adaptor flange onto the footed body.

Single-setup machining on state-of-the-art CNC production lines, the most recent calculation techniques and process controls give superior operational reliability, maximum output torques, high overhung and thrust load capacity, and long working life-time.

SYMBOLS & FORMULAS

D	[in]	Transmission element PCD	
F _r	[lb]	Application overhung load (OHL)	
F _{r1}	[lb]	Catalogue input overhung load (input OHL)	
F _{r2}	[lb]	Catalogue output overhung load (output OHL)	
F _{r2b(x)}	[lb]	Permissible OHL at position 'X' on output shaft, bearing lifetime condition	
F _{r2s(x)}	[lb]	Permissible OHL same as F _{r2b(x)} , shaft bending and torsional stress condition	
SF		Service factor	$FS = \frac{M_2}{M_{(app)}}$
i _n		Nominal reduction ratio	
i _r		Actual reduction ratio	
J ₁	[ft ² -lb]	Gearbox moment of inertia at input shaft	
J ₂	[ft ² -lb]	Application moment of inertia	
J _m	[ft ² -lb]	Motor moment of inertia	
k _(a)		Mass acceleration factor	
k _(t)		Transmission element factor	
Lub H/V	[pt]	Lubricant [pt]: H = horizontal mounting / V = vertical mounting	
M ₂	[in-lb]	Gearbox maximum output torque	$M_2 = \frac{1800 * P_1 * \eta}{n_2}$
M _(app)	[in-lb]	Application torque	
n ₁	[RPM]	Input speed	
n ₂	[RPM]	Output speed	
P ₁	[HP]	Input power @ 60Hz	$P_1 = \frac{M_2 * n_2}{1800 * \eta}$
W	[lb]	Weight: mounting B3-H & average reduction ratio	
η		Efficiency: 0.96 - 2-stage units 0.94 - 3-stage units	

Helical Gearboxes RD

MODULAR SYSTEM

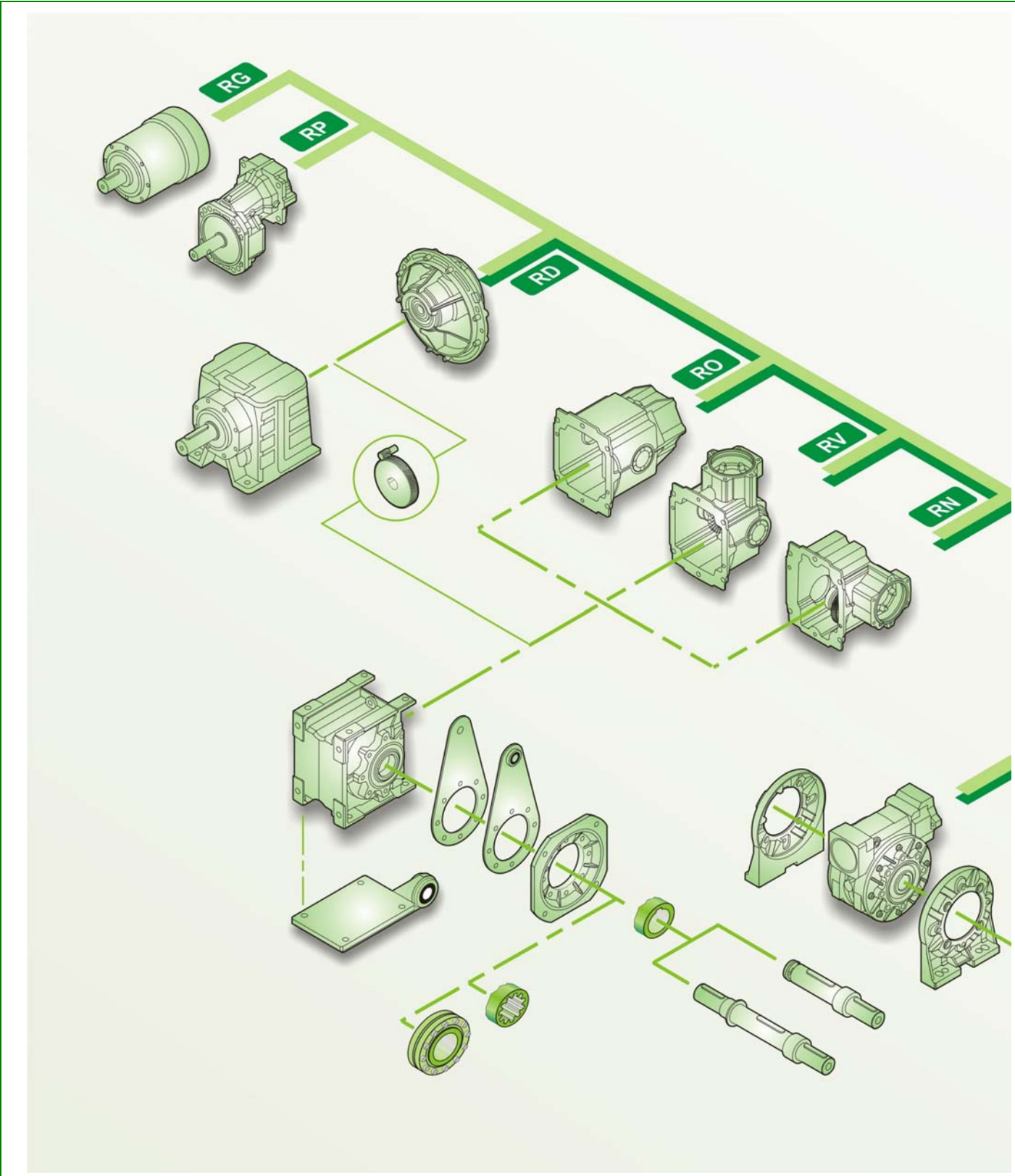

Helical Gearboxes RD

MODULAR SYSTEM

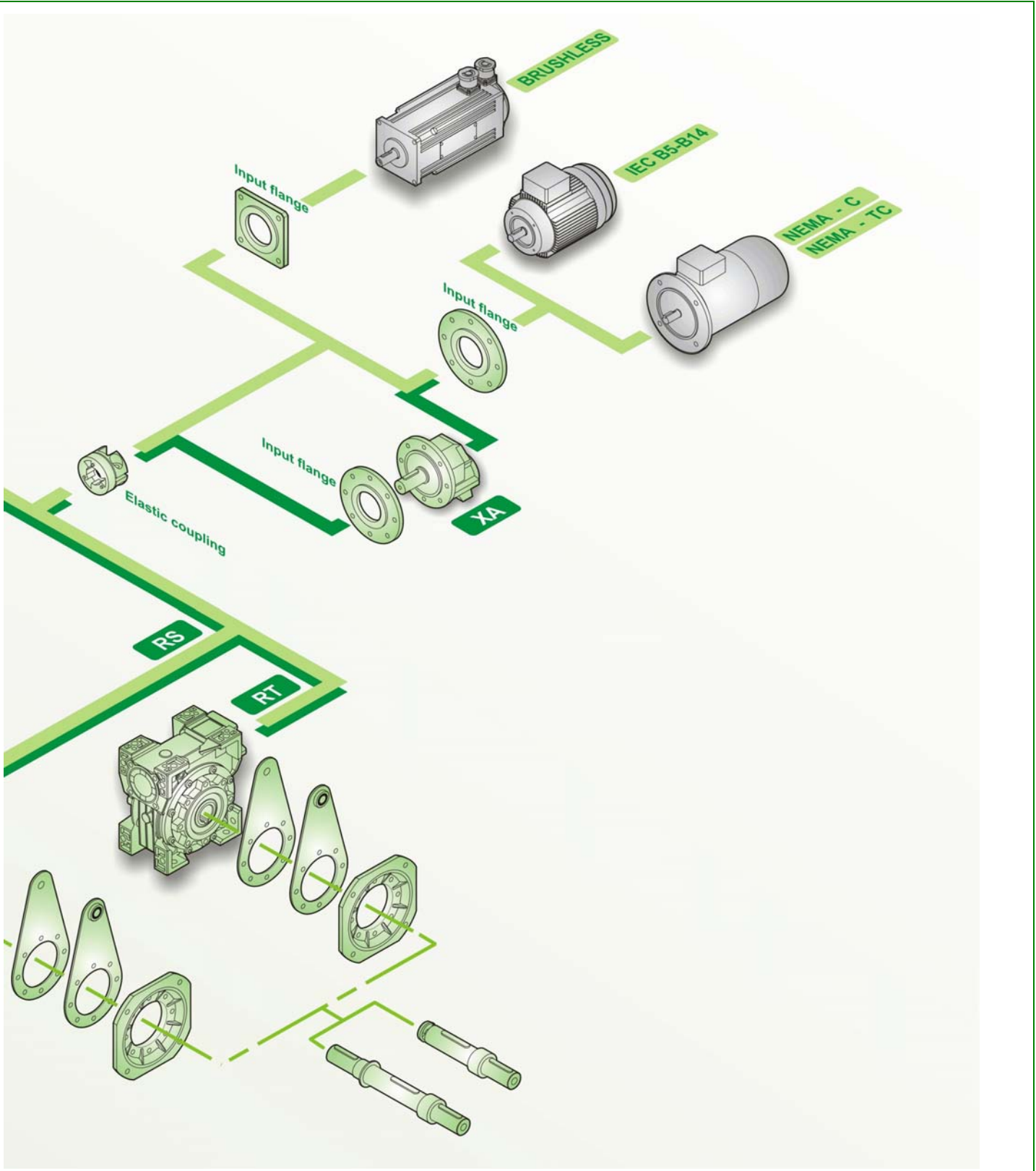

Helical Gearboxes RD

ELASTIC COUPLING "G"

Reducer half-coupling

- Material: steel alloy 20MnCr5
- Input shaft built-in
- Two bearing set
- Unchanged casing dimensions

Spider

- External tooth connection
- Material: Thermoplastic Elastomer
- Elastollan[®] TPU - Polyurethane
- Hytrel[®] TPE - Polyester
- Hardness
 - TPU 98 Shore A
 - TPE 72 Shore D
- Temperature
 - TPU -4 / +167 °F (-20/+75 °C)
 - TPE -22 / +212 °F (-30/+100 °C)

Motor half-coupling

- Material:
 - Aluminium die cast (G3, G5, G6)
 - Alloy steel 36SMnPb14 (GS8)
 - Alloy steel C43 on demand (GS3, GS5, GS6)
- Dynamic balancing
- Fitting:
 - Clamp (G3, G5, G6)
 - Key (GS3, GS5, GS6, GS8)
- Bores:
 - NEMA C / TC
 - IEC 72 / N42948

Advantages:

- One gearbox only for each reduction ratio
- Greater flexibility
- Increased stock rotation
- Fretting corrosion elimination between key and keyway
- Zero backlash in gearbox/motor connection
- Allowed angular misalignment 1° max
- High torsional rigidity
- High vibration damping

Input flanges:

- Material:
 - Aluminium up to IEC112 and NEMA 180TC
 - Cast iron from IEC 132 and NEMA 210TC

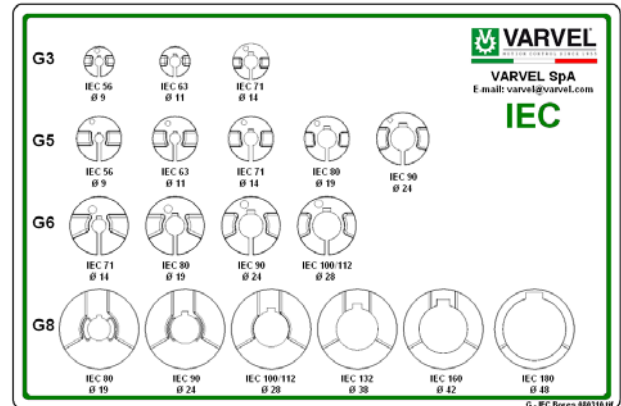
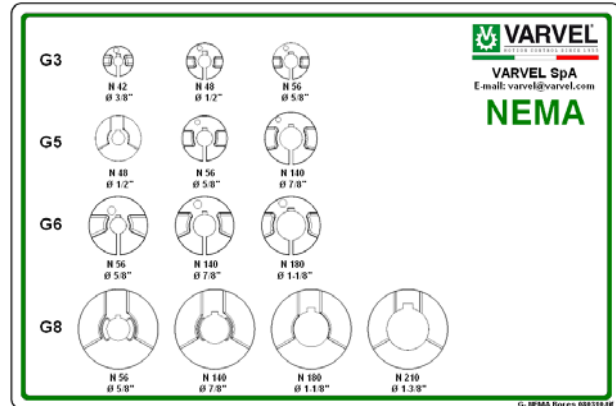

Helical Gearboxes RD

ELASTIC COUPLING "G" SELECTION

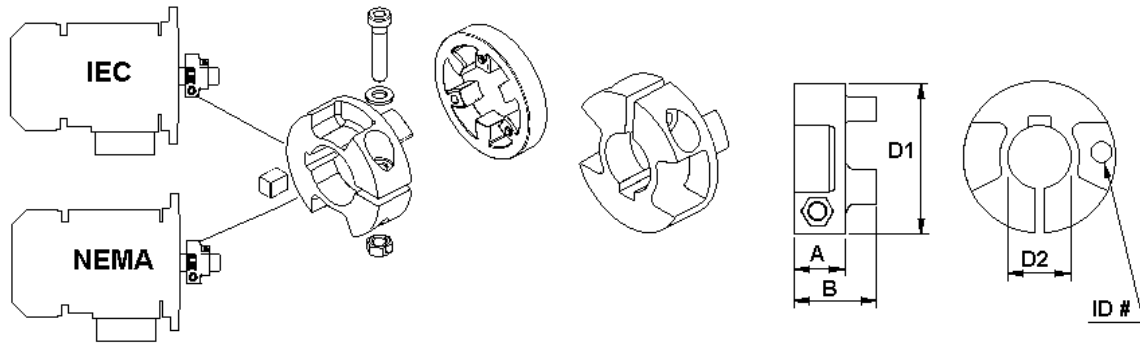

Coupling Size	IEC NEMA	Kit Code	RD Size	Mt [Nm]	Mt1 [Nm]	Mt2 [Nm]	A [mm]	B [mm]	D1 [mm]	D2 [mm / inch]	Coupling ID#
G3	IEC	KG3.009	03	4.5 - 6	15	8 - 10	11	19	30	9	309
		KG3.011	03	4.5 - 6	15	8 - 10			30	11	311
		KG3.014	03	7 - 8.5	28	18 - 22			36	14	314
	NEMA	KG3.N42	03	4.5 - 6	16	8 - 10			30	3/8"	3N42
		KG3.N48	03	4.5 - 6	18	10 - 12			36	1/2"	3N48
G5	IEC	KG5.009	02-12-13-23	8.9 - 10	14	8 - 10	14.5	23	45	9	509
		KG5.011	02-12-13-23		15	8 - 10			45	11	511
		KG5.014	02-12-13-23		30	12 - 17			45	14	514
		KG5.019	02-12-23		40	20 - 25			45	19	519
		KG5.024	12-23		70	30 - 40			52	24	524
	NEMA	KG5.N48	02		30	20 - 24			40	1/2"	5N48
		KG5.N56	02-12-13-23	45	30 - 35	45	5/8"	5N56			
		KG5.N140	12-23	60	40 - 45	52	7/8"	5N140			
G6	IEC	KG6.014	22-32-33-42-43	15.3 - 18	60	30 - 40	19.5	31.5	58	14	614
		KG6.019	22-32-33-42-43		90	50 - 65				19	619
		KG6.024	22-32-33-42-43		130	85 - 100				24	624
		KG6.028	22-32-42		180	100 - 120				28	628
		NEMA	KG6.N56		22-32-33-42-43	50				---	5/8"
		KG6.N140	22-32-33-42-43		85	---				7/8"	6N140
		KG6.N180	22-32-42-43	200	---	1-1/8"	6N180				
G8	IEC	* KGS8.19	52-53-62-63	15	150	---	35	51	79	19	819
		* KGS8.24	52-53-62-63		250	---				24	824
		* KGS8.28	52-53-62-63		350	---				28	828
		* KGS8.38	52-62-63		500	---				38	838
		* KGS8.42	52-62		500	---				42	842
		* KGS8.48	52-62		500	---				48	848
	NEMA	* KGS8.N056	52-53-62-63		140	---				5/8"	8N56
		* KGS8.N140	52-53-62-63		200	---				7/8"	8N140
		* KGS8.N180	52-53-62-63		300	---				1-1/8"	8N180
		* KGS8.N210	52-53-62-63		500	---				1-3/8"	8N210

Mt - Screw locking torque
 Mt1 - Transmissible torque with key
 Mt2 - Transmissible torque without key
 * - Coupling GS8: steel and key fit

Helical Gearboxes RD

NEMA FLANGES & ELASTIC COUPLINGS

RD	Flange	NEMA	Kit Code		
			Flange	Type	Kit Code
RD 02	FM 40	48 C	K531.227.N48	G5 ø 1/2"	KG5.N48
RD 03		56 C	K531.227.N56	G5 ø 5/8"	KG5.N56
RD 12	FM 50	42 C	K531.227.N48	G3 ø 3/8"	KG3.N42
RD 13		48 C	K531.227.N48	G3 ø 1/2"	KG3.N48
RD 22	FM 70	56 C	K532.227.N56	G5 ø 5/8"	KG5.N56
RD 23		140 TC	K532.227.N56	G5 ø 7/8"	KG5.N140
RD 32	FM 70	56 C	K533.227.N56	G6 ø 5/8"	KG6.N56
RD 33		140 C	K533.227.N56	G6 ø 7/8"	KG6.N140
RD 42	FM 85	180 C	K533.227.N180	G6 ø 1-1/8"	KG6.N180
RD 43		56 C	K533.227.N56	G5 ø 5/8"	KG5.N56
RD 52	FM 150	140 C	K533.227.N56	G5 ø 7/8"	KG5.N140
RD 53		180 C	K533.227.N56	G5 ø 5/8"	KG5.N180
RD 62	FM 150	210 TC	K533.227.N180	G6 ø 5/8"	KG6.N56
RD 63		56 C	K533.227.N56	G6 ø 7/8"	KG6.N140
RD 02	FM 40	48 C	K531.227.N48	G5 ø 1/2"	KG5.N48
RD 03		56 C	K531.227.N56	G5 ø 5/8"	KG5.N56
RD 12	FM 50	42 C	K531.227.N48	G3 ø 3/8"	KG3.N42
RD 13		48 C	K531.227.N48	G3 ø 1/2"	KG3.N48
RD 22	FM 70	56 C	K532.227.N56	G5 ø 5/8"	KG5.N56
RD 23		140 TC	K532.227.N56	G5 ø 7/8"	KG5.N140
RD 32	FM 70	56 C	K533.227.N56	G6 ø 5/8"	KG6.N56
RD 33		140 TC	K533.227.N56	G6 ø 7/8"	KG6.N140
RD 42	FM 85	180 TC	K533.227.N180	G6 ø 1-1/8"	KG6.N180
RD 43		56 C	K533.227.N56	G5 ø 5/8"	KG5.N56
RD 52	FM 150	140 TC	K533.227.N56	G5 ø 7/8"	KG5.N140
RD 53		180 TC	K533.227.N56	G5 ø 5/8"	KG5.N180
RD 62	FM 150	210 TC	K533.227.N180	G6 ø 5/8"	KG6.N56
RD 63		56 C	K533.227.N56	G6 ø 7/8"	KG6.N140
RD 02	FM 40	48 C	K531.227.N48	G5 ø 1/2"	KG5.N48
RD 03		56 C	K531.227.N56	G5 ø 5/8"	KG5.N56
RD 12	FM 50	42 C	K531.227.N48	G3 ø 3/8"	KG3.N42
RD 13		48 C	K531.227.N48	G3 ø 1/2"	KG3.N48
RD 22	FM 70	56 C	K532.227.N56	G5 ø 5/8"	KG5.N56
RD 23		140 TC	K532.227.N56	G5 ø 7/8"	KG5.N140
RD 32	FM 70	56 C	K533.227.N56	G6 ø 5/8"	KG6.N56
RD 33		140 TC	K533.227.N56	G6 ø 7/8"	KG6.N140
RD 42	FM 85	180 TC	K533.227.N180	G6 ø 1-1/8"	KG6.N180
RD 43		56 C	K533.227.N56	G5 ø 5/8"	KG5.N56
RD 52	FM 150	140 TC	K533.227.N56	G5 ø 7/8"	KG5.N140
RD 53		180 TC	K533.227.N56	G5 ø 5/8"	KG5.N180
RD 62	FM 150	210 TC	K533.227.N180	G6 ø 5/8"	KG6.N56
RD 63		56 C	K533.227.N56	G6 ø 7/8"	KG6.N140

* - Coupling GS8: steel and key fit

Helical Gearboxes RD

IEC FLANGES & ELASTIC COUPLINGS

RD	Flange	IEC	Kit Code		Coupling	
			Flange B5	Flange B14	Type	Kit Code
RD 02	FM 40	IEC56	K531.206.120	K531.206.080	G5 ø09	KG5.009
		IEC63	K531.206.140	K531.206.090	G5 ø11	KG5.011
		IEC71	K531.206.160	K531.206.105	G5 ø14	KG5.014
		IEC80	---	K531.206.120	G5 ø19	KG5.019
RD 03	FM 40	IEC56	K531.206.120	K531.206.080	G3 ø09	KG3.009
		IEC63	K531.206.140	K531.206.090	G3 ø11	KG3.011
		IEC71	K531.206.160	K531.206.105	G3 ø14	KG3.014
RD 12	FM 50	IEC56	K532.206.120	---	G5 ø09	KG5.009
		IEC63	K532.206.140	K532.206.090	G5 ø11	KG5.011
		IEC71	K532.206.160	K532.206.105	G5 ø14	KG5.014
		IEC80	K532.206.200	K532.206.120	G5 ø19	KG5.019
		IEC90	K532.206.200	K532.206.140	G5 ø24	KG5.024
RD 13	FM 50	IEC56	K532.206.120	---	G5 ø09	KG5.009
		IEC63	K532.206.140	K532.206.090	G5 ø11	KG5.011
		IEC71	K532.206.160	K532.206.105	G5 ø14	KG5.014
RD 22	FM 70	IEC71	K533.206.160	K533.206.105	G6 ø14	KG6.014
		IEC80	K533.206.200	K533.206.120	G6 ø19	KG6.019
		IEC90	K533.206.200	K533.206.140	G6 ø24	KG6.024
		IEC 100/112	K533.206.250	K533.206.160	G6 ø28	KG6.028
RD 23	FM 70	IEC63	K533.206.140	---	G5 ø11	KG5.011
		IEC71	K533.206.160	K533.206.105	G5 ø14	KG5.014
		IEC80	K533.206.200	K533.206.120	G5 ø19	KG5.019
		IEC90	K533.206.200	K533.206.140	G5 ø24	KG5.024
RD 32 RD 33	FM 70	IEC71	K533.206.160	K533.206.105	G6 ø14	KG6.014
		IEC80	K533.206.200	K533.206.120	G6 ø19	KG6.019
		IEC90	K533.206.200	K533.206.140	G6 ø24	KG6.024
		* IEC 100/112	K533.206.250	K533.206.160	G6 ø28	KG6.028
RD 42 RD 43	FM 85	IEC71	K534.206.160	---	G6 ø14	KG6.014
		IEC80	K534.206.200	K534.206.120	G6 ø19	KG6.019
		IEC90	K534.206.200	K534.206.140	G6 ø24	KG6.024
		** IEC 100/112	K534.206.250	K534.206.160	G6 ø28	KG6.028
RD 52	FM 130 & FM 150	IEC 80	K536.206.200	---	*** GS8 ø19	KGS8.019
		IEC 90	K536.206.200	---	*** GS8 ø24	KGS8.024
		IEC 100/112	K536.206.250	---	*** GS8 ø28	KGS8.028
		IEC 132	K537.206.300	K536.206.200	*** GS8 ø38	KGS8.038
		IEC 160	K565.206.350	K536.206.250	*** GS8 ø42	KGS8.042
		IEC 180	K565.206.350	---	*** GS8 ø48	KGS8.048
RD 53	FM 130	IEC 80	K536.206.200	---	*** GS8 ø19	KGS8.019
		IEC 90	K536.206.200	---	*** GS8 ø24	KGS8.024
		IEC 100/112	K536.206.250	---	*** GS8 ø28	KGS8.028
RD 62	FM 130 & FM 150	IEC 80	K536.206.200	---	*** GS8 ø19	KGS8.019
		IEC 90	K536.206.200	---	*** GS8 ø24	KGS8.024
		IEC 100/112	K536.206.250	---	*** GS8 ø28	KGS8.028
		IEC 132	K537.206.300	K536.206.200	*** GS8 ø38	KGS8.038
		IEC 160	K565.206.350	K536.206.250	*** GS8 ø42	KGS8.042
		IEC 180	K565.206.350	---	*** GS8 ø48	KGS8.048
RD 63	FM 130 & FM 150	IEC 80	K536.206.200	---	*** GS8 ø19	KGS8.019
		IEC 90	K536.206.200	---	*** GS8 ø24	KGS8.024
		IEC 100/112	K536.206.250	---	*** GS8 ø28	KGS8.028
		IEC 132	K537.206.300	K536.206.200	*** GS8 ø38	KGS8.038

- * - IEC100/112: not for RD33
- ** - IEC112: not for RD43
- *** - Coupling GS8: steel and key fit

Helical Gearboxes RD

ELECTRONIC CATALOGUE - 3D-MODELS - 2D-DRAWINGS



Modularity and flexibility have been leading the design of Varvel products since 2000. The gearbox-kit concept was carried out allowing anyone to assemble the unit in a few minutes with standard tooling.

This feature provides the highest flexibility to Varvel's distributors and resellers who - thanks to a limited kit selection - are able to immediately configure the required product.

VARSIZE® selection programme, available from our site

www.varvel.com

allows a friendly sizing of Varvel product range.

2D/3D Drawings

A guided selection allows 2D/3D models to be downloaded for the most popular CAD systems.

Guided selection

This service returns a list of applicable product configurations upon a given sequence of application parameters (power, output torque, rpm, service factor etc.); a PDF data sheet featuring performance data and dimensional drawings is generated for each configuration, as well as the 3D model and 2D drawings.



Helical Gearboxes RD

Example: FRD32/B3-H4 31.5 N56 AU35

ORDER DESIGNATION

F	RD	52	B3-H4		31.5	N56	AU	DFU
↓	↓	↓	↓		↓	↓	↓	↓
	<div style="border: 1px solid black; padding: 5px; width: fit-content; margin: auto;"> <p style="text-align: center; margin: 0;">TYPE</p> <hr style="border: 0; border-top: 1px solid black; margin: 5px 0;"/> <p style="text-align: center; margin: 0;">RD - Helical gearbox</p> </div>		<div style="border: 1px solid black; padding: 5px; width: fit-content; margin: auto;"> <p style="text-align: center; margin: 0;">MOUNTING POSITION</p> <hr style="border: 0; border-top: 1px solid black; margin: 5px 0;"/> <p style="text-align: center; margin: 0;">Page 5</p> <p style="text-align: center; margin: 0;">B3 - Foot mounting</p> <p style="text-align: center; margin: 0;">B5 - Flange mounting</p> </div>					<div style="border: 1px solid black; padding: 5px; width: fit-content; margin: auto;"> <p style="text-align: center; margin: 0;">OUTPUT FLANGE mm</p> <hr style="border: 0; border-top: 1px solid black; margin: 5px 0;"/> <p style="text-align: center; margin: 0;">120</p> <p style="text-align: center; margin: 0;">140</p> <p style="text-align: center; margin: 0;">160</p> <p style="text-align: center; margin: 0;">...</p> <p style="text-align: center; margin: 0;">300</p> <p style="text-align: center; margin: 0;">350</p> </div>
INPUT TYPE		SIZE		REDUCTION RATIO 1:		MOTOR ADAPTER	OUTPUT SHAFT DIA.	
		A)	B)	A)	B)	NEMA	in	
M - Motorized Unit F - Motor Flange S - Without Mtr Flange nil - Solid input		02	03	2.5	40	N42	0.625"	
		12	13	3.15	50	N48	0.750"	
		22	23	4.0	63	N56	1.000"	
		32	33	5.0	80	N140	1.250"	
		42	43	6.3	100	N180	1.375"	
		52	53	8.0	125	N210	1.625" / 2.125"	
		62	63	10.0	160		2.125" / 2.375"	
				12.5	200			
				16.0	250			
				20.0	315			
				25.0	400			
				31.5	500			
				40	630			
				50				
				63				
A) - 2-stages B) - 3-stages								

Helical Gearboxes RD

INPUT ARRANGEMENTS

NEMA INPUT

FRD NEMA	02	03	12	13	22	23	32	33	42	43	52	53	62	63
42	--	G3	--	--	--	--	--	--	--	--	--	--	--	--
48	G5	G3	--	--	--	--	--	--	--	--	--	--	--	--
56	G5	--	G5	G5	G6	G5	G6	G6	G6	G6	G8	G8	G8	G8
140	--	--	G5	--	G6	G5	G6	G6	G6	G6	G8	G8	G8	G8
180	--	--	--	--	G6	--	G6	--	G6	G6	G8	G8	G8	G8
210	--	--	--	--	--	--	--	--	--	--	G8	G8	G8	G8

G3, G5, G6 = Elastic coupling 'G' input, aluminium die cast type
 GS8 = Elastic coupling 'G' input, steel type

IEC INPUT

FRD IEC	02	03	12	13	22	23	32	33	42	43	52	53	62	63
56	□ ■	□ ■	□ ■	□ ■	--	--	--	--	--	--	--	--	--	--
63	□ ■	□ ■	□ ■	□ ■	--	□ ■	--	--	--	--	--	--	--	--
71	□ ■	□ ■	□ ■	□ ■	□ ■	□ ■	□ ■	□ ■	□ ■	□ ■	--	--	--	--
80	□ ■	--	□ ■	--	□ ■	□ ■	□ ■	□ ■	□ ■	□ ■	□ ■	□ ■	□ ■	□ ■
90	--	--	□ ■	--	□ ■	□ ■	□ ■	□ ■	□ ■	□ ■	□ ■	□ ■	□ ■	□ ■
100	--	--	--	--	□ ■	--	□ ■	--	□ ■	--	□ ■	□ ■	□ ■	□ ■
112	--	--	--	--	□ ■	--	□ ■	--	□ ■	--	□ ■	□ ■	□ ■	□ ■
132	--	--	--	--	--	--	--	--	■	--	□ ■	--	□ ■	□ ■
160	--	--	--	--	--	--	--	--	--	--	□ ■	--	□ ■	--
180	--	--	--	--	--	--	--	--	--	--	□ ■	--	□ ■	--

□ = IEC with G-Coupling (standard)
 ■ = IEC with quill input (on demand)

Helical Gearboxes RD

MOUNTING POSITIONS

B3

Foot mounting

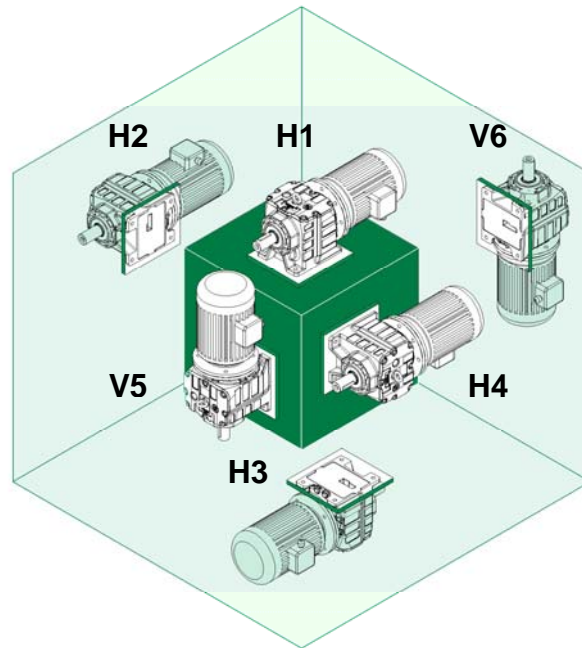

B5

Flange mounting

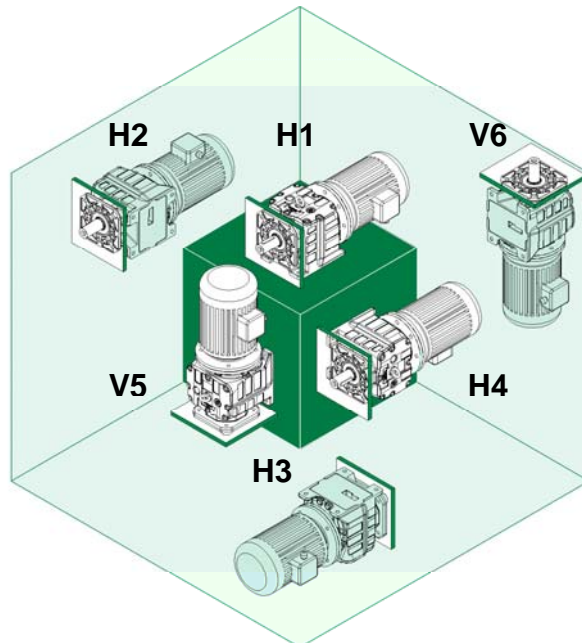

Helical Gearboxes RD

SERVICE FACTORS

SERVICE FACTOR of the gearbox

Service factor SF1.0 is meant as typical of 8 hours/day operation, with uniform load, starts/ stops lower than 60 per hour and ambient temperature between 60 and 95 °F.

The ratio between gearbox maximum output torque M_2 of each reduction ratio - listed in gearbox RD ratings, pages 10 to 16 - and application torque $M_{(app)}$ states the service factor to be bigger than the Application factors listed below.

Application	Load duration (hrs/day)			Application	Load duration (hrs/day)		
	< 3	3 - 10	> 10		< 3	3 - 10	> 10
Agitators (mixers)				Elevators			
Pure liquids	1.00	1.00	1.25	Bucket	1.00	1.25	1.50
Liquids and solids	1.00	1.00	1.50	Centrifugal discharge	1.00	1.00	1.25
Liquids - variable density	1.00	1.25	1.50	Escalators	1.00	1.00	1.25
Blowers				Freight	1.00	1.25	1.50
Centrifugal	1.00	1.00	1.25	Gravity discharge	1.00	1.00	1.25
Lobe	1.00	1.25	1.50	Extruders			
Vane	1.00	1.25	1.50	General	1.50	1.50	1.50
Brewing and distilling				Plastics			
Bottling machinery	1.00	1.25	1.25	Variable speed drive	1.50	1.50	1.50
Brew kettles - continuous duty	1.25	1.25	1.25	Fixed speed drive	1.75	1.75	1.75
Cookers - continuous duty	1.25	1.25	1.25	Rubber			
Mash tubs - continuous duty	1.25	1.25	1.25	Continuous screw operation	1.75	1.75	1.75
Scale hopper - frequent starts	1.25	1.25	1.25	Intermittent screw operation	1.75	1.75	1.75
Can filling machine	1.00	1.00	1.25	Fans			
Car dumpers	1.50	1.75	2.00	Centrifugal	1.00	1.00	1.25
Car pullers	1.00	1.25	1.50	Cooling towers	2.00	2.00	2.00
Clarifiers	1.00	1.00	1.25	Forced draft	1.25	1.25	1.25
Classifiers	1.00	1.25	1.50	Induced draft	1.50	1.50	1.50
Clay working machinery				Industrial and mine	1.50	1.50	1.50
Brick press	1.50	1.75	2.00	Feeders			
Briquette machine	1.50	1.75	2.00	Apron	1.00	1.25	1.50
Pug mill	1.00	1.25	1.50	Belt	1.00	1.25	1.50
Compactors	2.00	2.00	2.00	Disc	1.00	1.00	1.25
Compressors				Reciprocating	1.50	1.75	2.00
Centrifugal	1.00	1.00	1.25	Screw	1.00	1.25	1.50
Lobe	1.00	1.25	1.50	Food industry			
Reciprocating, multi-cylinder	1.50	1.50	1.75	Cereal cooker	1.00	1.00	1.25
Reciprocating, single-cylinder	1.75	1.75	2.00	Dough mixer	1.25	1.25	1.50
Conveyors				Meat grinders	1.25	1.25	1.50
- General purpose				Slicers	1.25	1.25	1.50
Uniformly loaded or fed	1.00	1.00	1.25	Generators and excitors	1.00	1.00	1.25
- Heavy duty				Hammer mills	1.75	1.75	2.00
Not uniformly fed	1.00	1.25	1.50	Hoists			
- Reciprocating or shaker	1.50	1.75	2.00	Heavy duty	1.25	1.75	2.00
Crusher				Medium duty	1.25	1.25	1.50
Stone or ore	1.75	1.75	2.00	Skip hoist	1.25	1.25	1.50
Dredges				Laundry			
Cable reels	1.25	1.25	1.50	Tumblers	1.25	1.25	1.50
Conveyors	1.25	1.25	1.50	Washers	1.50	1.50	2.00
Cutter head drives	2.00	2.00	2.00	Lumber industry			
Pumps	2.00	2.00	2.00	Barkers			
Screen drives	1.75	1.75	2.00	Spindle feed	1.25	1.25	1.50
Stackers	1.25	1.25	1.50	Main drive	1.75	1.75	1.75
Winches	1.25	1.25	1.50	Conveyors			
				Burner	1.25	1.25	1.50
				Main or heavy duty	1.50	1.50	1.50
				Main log	1.75	1.75	2.00
				Re-saw, merry-go-round	1.25	1.25	1.50

Helical Gearboxes RD

SERVICE FACTORS

Application	Load duration (hrs/day)			Application	Load duration (hrs/day)		
	< 3	3 - 10	> 10		< 3	3 - 10	> 10
Conveyors				Mixers			
Slab	1.75	1.75	2.00	Concrete	1.25	1.25	1.50
Transfer	1.25	1.25	1.50	Paper mills			
Chains				Agitator (mixer)	1.50	1.50	1.50
Floor	1.50	1.50	1.50	Agitator for pure liquors	1.25	1.25	1.25
Green	1.50	1.50	1.75	Barking drums	2.00	2.00	2.00
Cut-off saws				Barkers -mechanical	2.00	2.00	2.00
Chain	1.50	1.50	1.75	Beater	1.50	1.50	1.50
Drag	1.50	1.50	1.75	Breaker stack	1.25	1.25	1.25
Debarking drums	1.75	1.75	2.00	Calendar	1.25	1.25	1.25
Feeds				Chipper	2.00	2.00	2.00
Edger	1.25	1.25	1.50	Chip feeder	1.50	1.50	1.50
Gang	1.75	1.75	1.75	Coating rolls	1.25	1.25	1.25
Trimmer	1.25	1.25	1.50	Conveyors			
Log deck	1.75	1.75	1.75	Chip, bark, chemical	1.25	1.25	1.25
Log hauls - incline - well type	1.75	1.75	1.75	Log (including slab)	2.00	2.00	2.00
Log turning devices	1.75	1.75	1.75	Couch rolls	1.25	1.25	1.25
Planer feed	1.25	1.25	1.50	Cutter	2.00	2.00	2.00
Planer tilting hoists	1.50	1.50	1.50	Cylinder molds	1.25	1.25	1.25
Rolls -live-off bearings - roll cases	1.75	1.75	1.75	Dryers			
Sorting table	1.25	1.25	1.50	Paper machine	1.25	1.25	1.25
Tipple hoist	1.25	1.25	1.50	Conveyor type	1.25	1.25	1.25
Transfers				Embosser .	1.25	1.25	1.25
Chain	1.50	1.50	1.75	Extruder	1.50	1.50	1.50
Crane way	1.50	1.50	1.75	Fourdrinier rolls (includes lump breaker, dandy roll, wire turning, and return rolls)	1.25	1.25	1.25
Tray drives	1.25	1.25	1.50	Jordan	1.50	1.50	1.50
Veneer lathe drives	1.25	1.25	1.50	Kiln drive	1.50	1.25	1.50
Metal mills				Mt Hope roll	1.25	1.50	1.25
Draw bench carriage and main drive	1.25	1.25	1.50	Paper rolls	1.25	1.25	1.25
Runout table				Platter	1.50	1.50	1.50
Non-reversing				Presses - felt and suction	1.25	1.25	1.25
Group drives	1.50	1.50	1.50	Pulper	2.00	2.00	2.00
Individual drives	2.00	2.00	2.00	Pumps - vacuum	1.50	1.50	1.50
Reversing	2.00	2.00	2.00	Reel (surface type)	1.25	1.25	1.25
Slab pushers	1.50	1.50	1.50	Screens			
Shears	2.00	2.00	2.00	Chip	1.50	1.50	1.50
Wire drawing machine	1.25	1.25	1.50	Rotary	1.50	1.50	1.50
Wire winding machine	1.25	1.50	1.50	Vibrating	2.00	2.00	2.00
Metal strip processing machinery				Size press	1.25	1.25	1.25
Bridles	1.25	1.25	1.50	Super calendar	1.25	1.25	1.25
Coilers and uncoilers	1.00	1.00	1.25	Thickener (AC motor)	1.50	1.50	1.50
Edge trimmers	1.00	1.25	1.50	(DC motor)	1.25	1.25	1.25
Flatteners	1.25	1.25	1.50	Washer (AC motor)	1.50	1.50	1.50
Loopers (accumulators)	1.00	1.00	1.25	(DC motor)	1.25	1.25	1.25
Pinch rolls	1.25	1.25	1.50	Wind and unwind stand	1.00	1.00	1.25
Scrap choppers	1.25	1.25	1.50	Winders (surface type)	1.25	1.25	1.25
Shears	2.00	2.00	2.00	Yankee dryers	1.25	1.25	1.25
Slitters	1.00	1.25	1.50	Plastics industry			
Mills, rotary type				Primary processing			
Ball and rod	2.00	2.00	2.00	Intensive internal mixers			
Spur ring gear	2.00	2.00	2.00	Batch mixers	1.75	1.75	1.75
Helical ring gear	1.50	1.50	1.50	Continuous mixers	1.50	1.50	1.50
Direct connected	2.00	2.00	2.00	Batch drop mill - two smooth rolls	1.25	1.25	1.25
Cement kilns	1.50	1.50	1.50	Continuous feed, holding and blend mill	1.25	1.25	1.50
Dryers and coolers	1.50	1.50	1.50	Compounding mill	1.25	1.25	1.25
				Calendars	1.50	1.50	1.25

Helical Gearboxes RD

SERVICE FACTORS

Application	Load duration (hrs/day)			Application	Load duration (hrs/day)		
	< 3	3 - 10	> 10		< 3	3 - 10	> 10
Plastics industry				Sand muller	1.25	1.25	1.50
Secondary processing				Sewage disposal equipment			
Blow molders	1.50	1.50	1.50	Bar screens	1.25	1.25	1.25
Coating	1.25	1.25	1.25	Chemical feeders	1.25	1.25	1.25
Film	1.25	1.25	1.25	Dewatering screens	1.50	1.50	1.50
Pipe	1.25	1.25	1.25	Scum breakers	1.50	1.50	1.50
Pre-plasticizers	1.50	1.50	1.50	Slow or rapid mixers	1.50	1.50	1.50
Rods	1.25	1.25	1.25	Sludge collectors	1.25	1.25	1.25
Sheet	1.25	1.25	1.25	Thickeners	1.50	1.50	1.50
Tubing	1.25	1.25	1.50	Vacuum filters	1.50	1.50	1.50
Pullers - barge haul	1.25	1.25	1.50	Screens			
Pumps				Air washing	1.00	1.00	1.25
Centrifugal	1.00	1.00	1.25	Rotary - stone or gravel	1.25	1.25	1.50
Proportioning	1.25	1.25	1.00	Travelling water intake	1.00	1.00	1.25
Reciprocating				Sugar industry			
Single acting, three or more cylinders	1.25	1.25	1.50	Beet slicer	2.00	2.00	2.00
Double acting, two or more cylinders	1.25	1.25	1.50	Cane knives	1.50	1.50	1.50
Rotary				Crushers	1.50	1.50	1.50
Gear type	1.00	1.00	1.25	Mills (low speed end)	1.75	1.75	1.75
Lobe	1.00	1.00	1.25	Textile industry			
Vane	1.00	1.00	1.25	Batchers	1.25	1.25	1.50
Rubber industry				Calendars	1.25	1.25	1.50
Intensive internal mixers				Cards	1.25	1.25	1.50
Batch mixers	1.75	1.75	1.75	Dry cans	1.25	1.25	1.50
Continuous mixers	1.50	1.50	1.50	Dryers	1.25	1.25	1.50
Mixing mill - two smooth rolls (if corrugated rolls are used, then use the same selection factors that are used for a cracker warmer).	1.50	1.50	1.50	Dyeing machinery	1.25	1.25	1.50
Batch drop mill - two smooth rolls	1.50	1.50	1.50	Looms	1.25	1.25	1.50
Cracker warmer - two rolls; one corrugated roll	1.75	1.75	1.75	Mangles	1.25	1.25	1.50
Cracker - two corrugated rolls.	2.00	2.00	2.00	Nappers	1.25	1.25	1.50
Holding, feed and blend mill - two rolls	1.25	1.25	1.25	Pads	1.25	1.25	1.50
Refiner - two rolls	1.50	1.50	1.50	Slashers	1.25	1.25	1.50
Calendars	1.50	1.50	1.50	Soapers	1.25	1.25	1.50
				Spinners	1.25	1.25	1.50
				Tenter frames	1.25	1.25	1.50
				Washers	1.25	1.25	1.50
				Winders	1.25	1.25	1.50

This application guide is given by way of an example and therefore, may not include all the possible cases.

Should the application not be referable to any of the listed cases, the table below gives two service factors - one referred to both load type and work duration, and another one to starts and stops number of the duty cycle - of which the product is the gearbox oversizing coefficient in order to have a torque good enough to perform the required work.

Application: Conveyor 1000 in-lb @ 84 RPM - uniform load - 24 hrs/day → $F_1 = 1.4$; 60 start/stops per hour → $F_2 = 1.0$;

Required torque $1000 \times 1.4 \times 1.0 = 1400$ in-lb

Gearbox to select FRD22 1/20 (84 RPM) 1683 in-lb (gearbox service factor $SF_{1.7} = 1683$ in-lb : 1000 in-lb)

SERVICE FACTOR

$$SF = F_1 \times F_2$$

F_1 = Load & time factor
 a = Uniform load
 b = Variable load
 c = Shock load
 F_2 = Running factor
 d = Start/stops per hour

	F_1	a	b	c	F_2	d
	3 - 4 hrs	0.8	1.0	1.5	6	0.8
	8 - 10 hrs	1.0	1.2	1.8	60	1.0
	10 - 24 hrs	1.4	1.6	2.0	120	1.2

Helical Gearboxes RD

EXTERNAL LOADS

OHL - OVERHUNG LOADS - OUTPUT [lb]

Overhung (radial) loads have to be checked with the rating factor F_{r2} given in the selection tables.

Each transmission element fitted on the gearbox output shaft gives its own transmission element factor $k_{(t)}$ according to the following table.

- Application OHL

$k_{(t)}$	Transmission Element	
1.15	Gear	- Tooth No. < 17
1.40	Chain sprocket	- Tooth No. < 13
1.25	Chain sprocket	- Tooth No. < 20
1.00	Chain sprocket	- Tooth No. > 20
2.50	V-belt pulley	
1.25	Toothed belt pulley	

$$F_r = \frac{2 * M_2}{D} * k_{(t)}$$

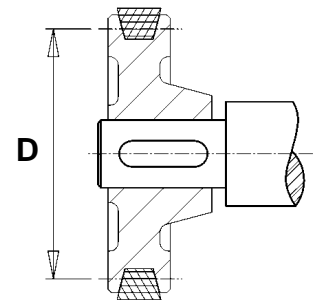

- Catalogue OHL at mid shaft $F_{r2} \geq F_r$ Catalogue value to be greater than application OHL

RD	0	1	2	3	4	5	6
a [inch]	0.69	0.79	0.98	1.18	1.38	1.57	1.97
a [mm]	17.5	20	25	30	35	40	50

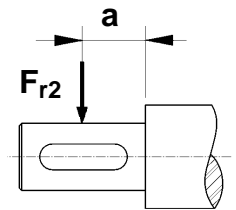

- OHL offset from gearbox centre * or ** values as appropriate to be greater than application OHL

$$F_{r2b(x)} \geq F_r$$

$$F_{r2b(x)} = F_{r2} * \frac{c}{x + b}$$

$$F_{r2s(x)} \geq F_r$$

$$F_{r2s(x)} = F_{r2} * \frac{a}{x}$$

RD	0	1	2	3	4	5	6
a [inch]	0.69	0.79	0.98	1.18	1.38	1.57	1.97
b [inch]	0.61	0.91	0.94	1.06	1.22	1.46	1.54
c [inch]	1.30	1.69	1.93	2.24	2.60	3.03	3.50

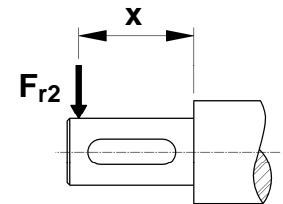

AXIAL LOADS - OUTPUT

Axial load values are assumed to be 20% of OHL, either on tensile and compressive stress, besides OHL itself.

$$F_{a2} = F_{r2} * 0.2$$

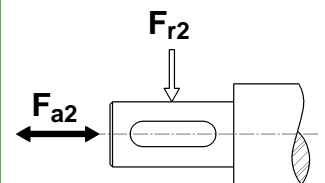

Helical Gearboxes RD

COMPONENTS & CONVERSION FACTORS

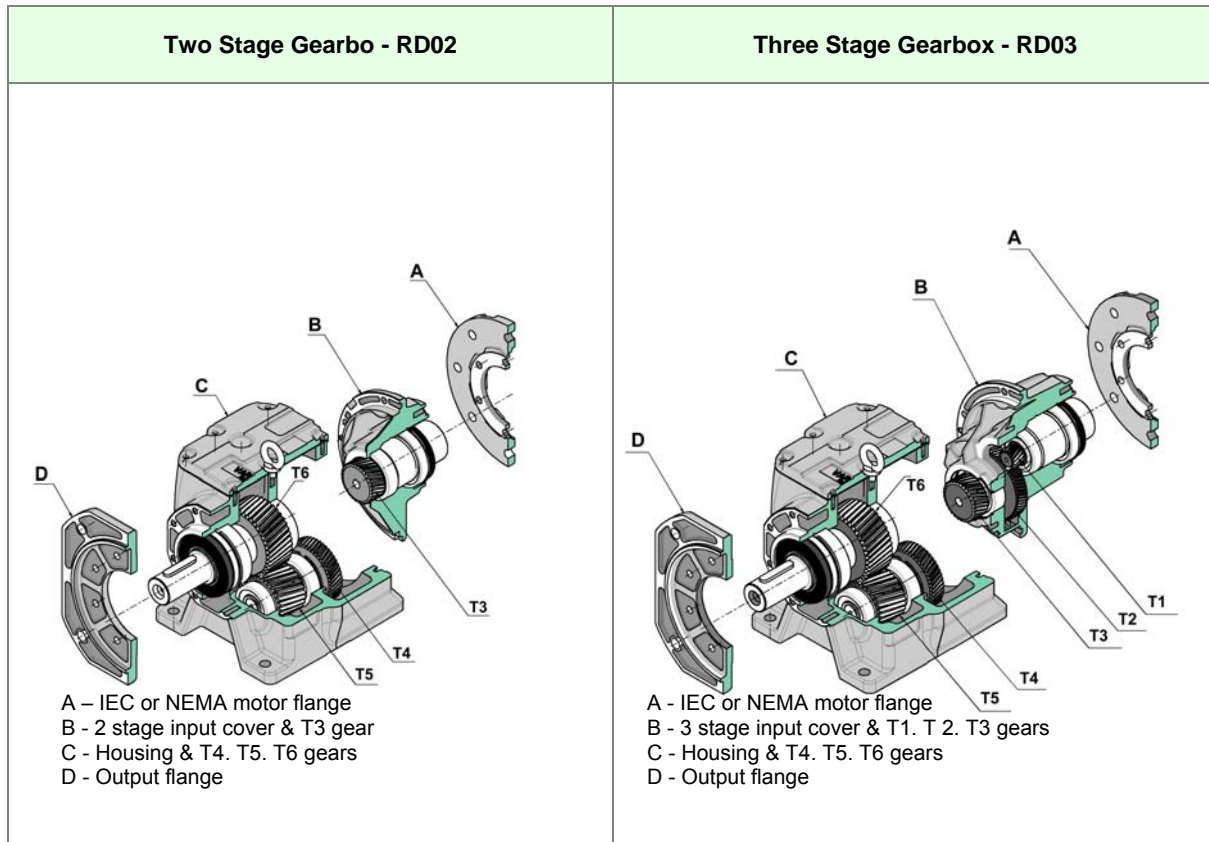

Imperial	CONVERSIONS	Metric
1 lb = 4.45 N 1 lb = 0.454 kg 1 oz = 0.028 kg	Mass & Force	1 N = 0.225 lb 1 kg = 2.205 lb 1 kg = 35.27 oz
HP (60Hz) = kW (50Hz) × 1.341 × 1.2 HP (50 Hz) = kW (50 Hz) × 1.341 HP = in-lb × RPM : (63025 × eff.)	Power	kW (50 Hz) = HP (60 Hz) × 0.745 × 0.833 kW (50 Hz) = HP (50 Hz) × 0.745 kW = Nm × RPM : (9550 × eff.)
1 in-lb = 0.113 Nm 1 ft-lb = 1.355 Nm ft-lb = 108 × k × HP × eff. × ratio in-lb = 9 × k × HP × eff. × ratio = 8000 × k × HP × eff. × o/p speed (where k = motor pole #, i.e. 2, 4, 6, 8)	Torque	1 Nm = 8.851 in-lb 1 Nm = 0.738 ft-lb Nm = 9550 × kW × eff. : RPM
1 qt (US) = 0.946 litre	Volume	1 litre = 1.057 qt (US)

RD02 & RD03

Helical Gearboxes RD

1800 RPM

SELECTION

440 in-lb	i_n	i_r	n_2	M_2	P_1	F_{r1}	F_{r2}	$J_1 \times 10^{-4}$	NEMA SIZES		
	nominal	actual	[RPM]	[in-lb]	[HP]	[lb]	[lb]	[lb x ft ²]	42	48	56
RD02 2s	2,5	2.568	654	266	3.05	*	97	12.4608		G5	G5
	3,15	3.277	512	292	2.63	*	94	10.5434		G5	G5
	4,0	4.256	395	319	2.21	*	97	9.2169		G5	G5
	5,0	5.276	318	336	1.89	*	117	8.5121		G5	G5
	6,3	6.253	281	425	2.04	8	144	10.1946		G5	G5
	8,0	7.979	210	434	1.63	25	162	9.1504		G5	G5
	10,0	10.362	162	443	1.31	39	184	8.3911		G5	G5
	12,5	12.844	131	443	1.04	47	207	7.9758		G5	G5
	16,0	16.320	103	451	0.82	55	229	7.6364		G5	G5
	20,0	21.533	78	451	0.64	61	263	7.3706		G5	G5
	25,0	26.747	62	460	0.52	66	270	7.2259		G5	G5
	31,5	30.222	55	460	0.45	67	270	7.1642		G5	G5
	35,5	34.675	48	310	0.27	143	321	7.3303		G5	G5
	40	43.070	40	310	0.22	145	321	7.1974		G5	G5
50	48.667	35	310	0.18	146	319	7.1428		G5	G5	
RD03 3s	40	36.892	44	460	0.37	17	270	7.2734	G3	G3	
	50	47.074	36	460	0.30	33	270	15.2610	G3	G3	
	63	61.135	28	460	0.23	47	270	15.0498	G3	G3	
	80	75.782	22	460	0.18	56	270	14.9478	G3	G3	
	100	96.288	18	460	0.15	63	270	14.8789	G3	G3	
	125	127.047	13	460	0.12	70	270	14.8362	G3	G3	
	160	157.805	11	460	0.08	75	270	14.8172	G3	G3	
	180	178.311	9.5	460	0.08	77	270	14.8101	G3	G3	
	200	204.583	8.3	319	0.05	82	319	14.8338	G3	G3	
	250	254.113	6.6	319	0.03	84	319	14.8172	G3	G3	
	280	287.133	5.9	319	0.03	85	319	14.8101	G3	G3	
315	324.444	5.2	319	0.03	85	319	15.3346	G3	G3		
<p>2s & 3s - Number of reduction stages * - Recommended input in-line coupling drive G3, G5 - Elastic coupling 'G type' input</p>											
RD	Lub. H		Lub. V		Weight						
	US qt	litres	US qt	litres	lb	kg					
02	0.21	0.20	0.30	0.28	6.7	3.0					
03	0.32	0.30	0.40	0.38	7.2	3.2					

Helical Gearboxes RD

RD12 & RD13

SELECTION

1800 RPM

885 in-lb	i_n	i_r	n_2	M_2	P_1	F_{r1}	F_{r2}	$J_1 \times 10^{-4}$	NEMA SIZES	
	nominal	actual	[RPM]	[in-lb]	[HP]	[lb]	[lb]	[lb x ft ²]	56	140
RD12 2s	2.5	2.534	672	398	4.19	*	292	26.4641	G5	G5
	3.15	3.081	534	398	3.70	*	315	22.1452	G5	G5
	4	4.011	420	443	3.08	*	337	18.2510	G5	G5
	5	5.073	336	487	2.60	*	360	15.9753	G5	G5
	6.3	6.686	264	797	3.45	*	382	19.8315	G5	G5
	8	8.129	210	797	2.87	*	405	17.6578	G5	G5
	10	10.581	168	797	2.23	*	427	15.6027	G5	G5
	12.5	13.384	132	797	1.78	*	427	14.3213	G5	G5
	16	16.309	108	797	1.48	4	427	13.5500	G5	G5
	20	20.391	84	797	1.19	12	427	12.8975	G5	G5
	25	26.522	66	841	0.94	17	449	12.3659	G5	G5
	31.5	32.653	54	841	0.77	22	449	12.0740	G5	G5
	40	39.083	42	620	0.45	133	449	12.3018	G5	G5
	50	48.118	36	620	0.37	142	449	12.0313	G5	G5
63	61.670	26	620	0.28	144	449	11.8059	G5	G5	
RD13 3s	40	40.103	42	841	0.64	27	337	12.4988	G5	
	50	52.201	36	841	0.49	47	360	36.8319	G5	
	63	66.028	26	841	0.39	61	382	36.5305	G5	
	80	80.432	22	885	0.32	72	405	36.3858	G5	
	100	100.596	17	885	0.27	79	427	36.2790	G5	
	125	130.843	13	885	0.20	90	449	36.2125	G5	
	160	165.075	11	885	0.17	92	449	46.1793	G5	
	200	206.460	8.4	885	0.13	94	449	46.0915	G5	
	250	268.538	6.6	885	0.10	97	449	46.0393	G5	
	315	330.615	5.4	885	0.08	101	449	46.0155	G5	
	400	395.719	4.2	620	0.05	108	494	46.0393	G5	
	500	487.197	3.4	620	0.03	110	494	46.0155	G5	
630	624.413	2.6	620	0.03	115	494	46.0013	G5		
2s & 3s	- Number of reduction stages									
*	- Recommended input in-line coupling drive									
G5	- Elastic coupling 'G type' input									
RD	Lub. H		Lub. V		Weight					
	US qt	litres	US qt	litres	lb	kg				
12	0.53	0.50	0.74	0.70	10.8	4.8				
13	0.53	0.50	0.90	0.85	10.8	4.8				

RD22 & RD23

Helical Gearboxes RD

1800 RPM

SELECTION

1770 in-lb	i_n	i_r	n_2	M_2	P_1	F_{r1}	F_{r2}	$J_1 \times 10^{-4}$	NEMA SIZES		
	nominal	actual	[RPM]	[in-lb]	[HP]	[lb]	[lb]	[lb x ft ²]	56	140	180
RD22 2s	2.5	2.548	672	752	8.36	*	247	82.0335	G6	G6	G6
	3.15	3.133	534	797	7.33	*	303	68.8062	G6	G6	G6
	4	3.917	420	885	6.29	*	337	58.9889	G6	G6	G6
	5	5.013	336	929	5.23	*	382	51.7702	G6	G6	G6
	6.3	6.717	264	1549	6.92	*	416	64.6605	G6	G6	G6
	8	8.267	210	1593	5.68	*	449	57.3373	G6	G6	G6
	10	10.333	168	1593	4.59	*	472	51.6491	G6	G6	G6
	12.5	13.227	132	1593	3.64	*	494	47.2899	G6	G6	G6
	16	16.29	108	1637	2.98	*	517	44.6748	G6	G6	G6
	20	20.667	84	1682	2.38	*	539	42.5343	G6	G6	
	25	26.729	66	1682	1.86	9	562	40.8969	G6	G6	
	31.5	31.477	54	1682	1.59	11	584	40.1921	G6	G6	
	40	39.388	42	1239	0.89	162	652	39.4019	G6		
	50	50.758	36	1239	0.69	166	685	39.7650	G6		
63	62.127	26	1239	0.57	171	719	39.2429	G6			
RD23 3s	40	40.759	42	1770	1.26	31	517	41.5305	G5	G5	
	50	52.172	36	1770	0.99	63	539	61.0084	G5	G5	
	63	64.256	26	1770	0.80	85	562	60.4887	G5		
	80	81.519	22	1770	0.65	103	584	60.1256	G5		
	100	105.431	17	1770	0.50	124	607	59.8717	G5		
	125	124.159	13	1770	0.42	133	629	59.7886	G5		
	160	164.938	11	1770	0.32	97	652	73.5617	G5		
	200	209.25	8.4	1770	0.25	117	674	73.3007	G5		
	250	270.63	6.6	1770	0.20	130	719	73.1275	G5		
	315	318.704	5.4	1770	0.17	135	787	73.0800	G5		
	400	398.802	4.2	1239	0.10	157	787	73.1109	G5		
500	513.92	3.4	1239	0.07	164	787	73.0658	G5			
630	629.039	2.6	1239	0.07	171	787	73.0492	G5			
<p>2s & 3s - Number of reduction stages * - Recommended input in-line coupling drive G5, G6 - Elastic coupling 'G type' input</p>											
RD	Lub. H		Lub. V		Weight						
	US qt	litres	US qt	litres	lb	kg					
22	0.85	0.80	1.06	1.0	17.8	7.9					
23	0.85	0.80	1.32	1.25	19.1	8.5					

Helical Gearboxes RD

RD32 & RD33

SELECTION

1800 RPM

3720 in-lb	i_n	i_r	n_2	M_2	P_1	F_{r1}	F_{r2}	$J_1 \times 10^{-4}$	NEMA SIZES		
	nominal	actual	[RPM]	[in-lb]	[HP]	[lb]	[lb]	[lb x ft ²]	56	140	180
RD32 2s	2.5	2.697	672	1682	17.58	187	472	179.416	G6	G6	G6
	3.15	3.324	534	1814	15.39	191	494	140.133	G6	G6	G6
	4	4.160	420	1947	13.19	198	517	111.032	G6	G6	G6
	5	5.331	336	2080	10.98	202	562	89.5560	G6	G6	G6
	6.3	6.261	264	3275	15.61	207	607	125.695	G6	G6	G6
	8	7.717	210	3275	12.79	220	697	104.767	G6	G6	G6
	10	9.658	168	3319	10.34	231	809	88.4525	G6	G6	G6
	12.5	12.375	132	3363	8.16	240	854	75.8043	G6	G6	G6
	16	16.451	108	3452	6.24	249	899	77.1023	G6	G6	G6
	20	19.362	84	3452	5.35	249	944	68.9319	G6	G6	G6
	25	25.255	66	3496	4.16	258	1011	56.5898	G6	G6	G6
	31.5	33.214	54	3540	2.82	272	1056	53.2699	G6	G6	G6
	40	38.571	42	2522	1.84	310	1101	55.8874	G6	G6	G6
	50	50.727	36	2522	1.42	312	1124	52.8617	G6	G6	
63	63.333	26	2522	1.16	315	1124	51.1888	G6	G6		
RD33 3s	40	38.063	42	3717	2.82	22	899	56.5945	G6	G6	
	50	48.772	36	3717	2.23	79	921	114.444	G6	G6	
	63	64.836	26	3717	1.69	130	944	123.789	G6	G6	
	80	76.310	22	3717	1.46	155	989	119.072	G6	G6	
	100	99.535	17	3762	1.12	187	1011	111.027	G6	G6	
	125	130.903	13	3762	0.85	196	1034	110.643	G6		
	160	167.799	11	3762	0.67	191	1056	162.119	G6		
	200	197.495	8.4	3762	0.57	202	921	157.598	G6		
	250	257.602	6.6	3806	0.44	209	966	149.530	G6		
	315	307.214	5.4	3806	0.37	213	1011	149.656	G6		
	400	393.429	4.2	2567	0.18	258	1124	149.807	G6		
	500	517.418	3.4	2567	0.15	263	1124	149.591	G6		
630	646.000	2.6	2567	0.12	270	1124	149.499	G6			
2s & 3s	- Number of reduction stages										
G6	- Elastic coupling 'G type' input										
RD	Lub. H		Lub. V		Weight						
	US qt	litres	US qt	litres	lb	kg					
32	1.4	1.3	1.9	1.8	30.3	13.5					
33	1.7	1.6	2.2	2.1	32.6	14.5					

RD42 & RD43

Helical Gearboxes RD

1800 RPM

SELECTION

6200 in-lb	i_n	i_r	n_2	M_2	P_1	F_{r1}	F_{r2}	$J_1 \times 10^{-4}$	NEMA SIZES		
	nominal	actual	[RPM]	[in-lb]	[HP]	[lb]	[lb]	[lb x ft ²]	56	140	180
RD42 2s	2.5	2.489	672	2655	29.67	110	517	442.880	G6	G6	G6
	3.15	3.111	534	2832	25.65	119	562	355.386	G6	G6	G6
	4	3.960	420	3363	23.80	126	607	292.287	G6	G6	G6
	5	4.830	336	3540	20.62	130	674	256.478	G6	G6	G6
	6.3	6.286	264	5487	25.48	225	697	323.587	G6	G6	G6
	8	7.857	210	5487	20.62	240	787	279.045	G6	G6	G6
	10	10.000	168	5487	16.43	256	831	245.158	G6	G6	G6
	12.5	12.199	132	5487	13.41	265	1034	224.819	G6	G6	G6
	16	15.223	108	5753	11.06	272	1281	208.049	G6	G6	G6
	20	19.643	84	5753	9.55	281	1303	194.297	G6	G6	G6
	25	24.478	66	5753	7.04	285	1348	185.728	G6	G6	G6
	31.5	29.643	54	5753	5.87	288	1371	180.469	G6	G6	G6
	40	41.538	42	3983	2.51	355	1573	184.038	G6	G6	
	50	50.303	36	3983	2.01	357	1685	179.318	G6	G6	
63	62.963	26	3983	1.84	357	1798	175.272	G6	G6		
RD43 3s	40	41.875	42	6196	4.19	90	1124	178.414	G6	G6	
	50	51.084	36	6196	3.52	144	1146	234.833	G6	G6	
	63	63.747	26	6196	2.51	193	1169	243.924	G6	G6	
	80	82.254	22	6196	2.85	240	1169	238.775	G6	G6	
	100	102.502	17	6196	1.84	272	1191	230.578	G6	G6	
	125	124.129	13	6196	1.51	294	1214	230.118	G6	G6	
	160	160.689	11	6196	1.17	281	1236	281.371	G6	G6	
	200	207.341	8.4	6196	1.01	261	1258	276.767	G6	G6	
	250	258.379	6.6	6196	0.67	290	1303	268.723	G6		
	315	312.297	5.4	6196	0.59	312	1348	268.770	G6		
	400	438.462	4.2	4071	0.37	362	1573	268.936	G6		
	500	530.976	3.4	4071	0.20	371	1685	268.723	G6		
630	664.609	2.6	4071	0.18	375	1798	268.604	G6			
2s & 3s - Number of reduction stages G6 - Elastic coupling 'G type' input											
RD	Lub. H		Lub. V		Weight						
	US qt	litres	US qt	litres	lb	kg					
42	2.3	2.2	3.2	3.0	45.0	20.0					
43	2.3	2.2	3.6	3.4	48.3	21.5					

Helical Gearboxes RD

RD52 & RD53

SELECTION

1800 RPM

11,500 in-lb	i_n	i_r	n_2	M_2	P_1	F_{r1}	F_{r2}	$J_1 \times 10^{-4}$	NEMA SIZES			
	nominal	actual	[RPM]	[in-lb]	[HP]	[lb]	[lb]	[lb x ft ²]	56	140	180	210
RD52 2s	2.5	2.557	672	5576	54,75	169	765	620,027	G8	G8	G8	G8
	3.15	3.241	534	6107	48,31	178	833	497,531	G8	G8	G8	G8
	4	3.926	420	6638	46,70	191	900	409,206	G8	G8	G8	G8
	5	4.840	336	7523	43,16	196	1013	359,064	G8	G8	G8	G8
	6.3	6.454	264	10267	44,12	338	1035	552,680	G8	G8	G8	G8
	8	8.185	210	10356	35,11	360	1170	390,673	G8	G8	G8	G8
	10	9.915	168	10444	29,15	383	1238	343,212	G8	G8	G8	G8
	12.5	12.222	132	10533	23,83	401	1553	314,759	G8	G8	G8	G8
	16	15.452	108	10621	19,00	410	1913	291,266	G8	G8	G8	G8
	20	20.298	84	10798	14,65	421	1958	272,021	G8	G8	G8	G8
	25	25.989	66	10887	11,59	428	2025	260,156	G8	G8	G8	G8
	31.5	31.429	54	10975	9,66	432	2048	252,657	G8	G8	G8	G8
	40	40.476	42	7523	5,15	540	2363	257,664	G8	G8	G8	
	50	53.333	36	7523	3,86	551	2520	251,043	G8	G8		
63	66.667	26	7523	3,06	563	2700	245,372	G8	G8			
RD53 3s	40	39.333	42	11241	8,05	158	1710	249,786	G8	G8	G8	
	50	47.984	36	11329	6,60	218	1755	328,760	G8	G8	G8	
	63	59.878	26	11418	5,48	290	1755	341,504	G8	G8	G8	
	80	77.262	22	11506	4,19	362	1778	334,290	G8	G8	G8	
	100	96.280	17	11506	3,38	410	1778	322,804	G8	G8		
	125	129.800	13	11506	2,58	446	1823	322,163	G8	G8		
	160	157.143	11	11506	2,09	326	1845	393,924	G8	G8		
	200	195.824	8.4	11506	1,77	394	1890	387,469	G8	G8		
	250	264.000	6.6	11506	1,29	434	1958	376,221	G8	G8		
	315	332.308	5.4	7966	0,72	473	2025	376,292	G8			
	400	402.424	4.2	7966	0,56	540	2363	376,506	G8			
	500	503.704	3.4	7966	0,48	563	2520	376,221	G8			
630	629.630	2.6	7966	0,40	574	2700	376,055	G8				
2s & 3s - Number of reduction stages G8 - Elastic coupling 'G type' input												
RD	Lub. H		Lub. V		Weight							
	US qt	litres	US qt	litres	lb	kg						
52	4.8	4.5	5.8	5.5	110	49						
53	4.8	4.5	6.9	6.5	117	52						

RD62 & RD63

Helical Gearboxes RD

1800 RPM

SELECTION

20,350 in-lb	i_n	i_r	n_2	M_2	P_1	F_{r1}	F_{r2}	$J_1 \times 10^{-4}$	NEMA SIZES			
	nominal	actual	[RPM]	[in-lb]	[HP]	[lb]	[lb]	[lb x ft ²]	56	140	180	210
RD62 2s	2.5	2.616	642	11506	117.34	247	1146	1594.37	G8	G8	G8	G8
	3.15	3.318	506	12391	100.57	258	1258	1279.40	G8	G8	G8	G8
	4	4.019	418	14161	97.22	274	1348	1052.23	G8	G8	G8	G8
	5	4.955	340	15931	92.86	285	1506	923.325	G8	G8	G8	G8
	6.3	6.571	256	17702	78.45	490	1551	1421.21	G8	G8	G8	G8
	8	8.333	202	17702	61.35	526	1753	1004.55	G8	G8	G8	G8
	10	10.095	167	18587	53.14	562	1865	882.580	G8	G8	G8	G8
	12.5	12.444	136	18587	43.08	584	2315	809.348	G8	G8	G8	G8
	16	15.733	107	18587	34.03	596	2877	748.978	G8	G8	G8	G8
	20	20.667	82	18587	25.98	607	2921	699.500	G8	G8	G8	G8
	25	24.615	68	18587	21.79	618	3034	668.911	G8	G8	G8	G8
	31.5	33.200	50	19649	16.76	640	3079	649.690	G8	G8	G8	G8
	40	40.500	42	14161	10.06	764	3528	662.528	G8	G8	G8	G8
	50	49.800	34	14161	8.21	775	3775	645.537	G8	G8	G8	G8
63	56.000	30	14161	7.21	787	4045	630.990	G8	G8	G8	G8	
RD63 3s	40	39.708	42	19472	14.42	202	2562	642.286	G8	G8	G8	G8
	50	48.948	35	19472	11.73	315	2629	845.394	G8	G8	G8	G8
	63	61.884	28	19472	9.22	420	2629	878.118	G8	G8	G8	G8
	80	81.289	20	20357	7.38	539	2674	859.585	G8	G8	G8	G8
	100	104.082	16	20357	6.20	584	2674	830.088	G8	G8	G8	
	125	125.867	13	20357	5.70	629	2697	828.427	G8	G8	G8	
	160	157.333	11	20357	4.69	472	2764	1012.93	G8	G8	G8	
	200	201.571	8.3	20357	3.02	562	2832	996.367	G8	G8	G8	
	250	265.600	6.4	20357	2.35	629	2921	967.392	G8	G8		
	315	332.000	5.0	20357	1.84	674	3034	967.582	G8	G8		
	355	373.333	3.7	20357	2.68	787	3528	968.175	G8	G8		
	450	448.000	3.7	20357	1.34	809	3775	967.392	G8	G8		
	560	560.000	3.0	20357	1.17	831	4045	966.965	G8	G8		
2s & 3s - Number of reduction stages G8 - Elastic coupling 'G type' input												
RD	Lub. H		Lub. V		Weight							
	US qt	litres	US qt	litres	lb	kg						
62	7.4	7.0	9.5	9.0	139	62						
63	7.4	7.0	11.6	11.0	157	70						

Helical Gearboxes RD

RD02 & RD03

DIMENSIONS

FOOT MOUNTING

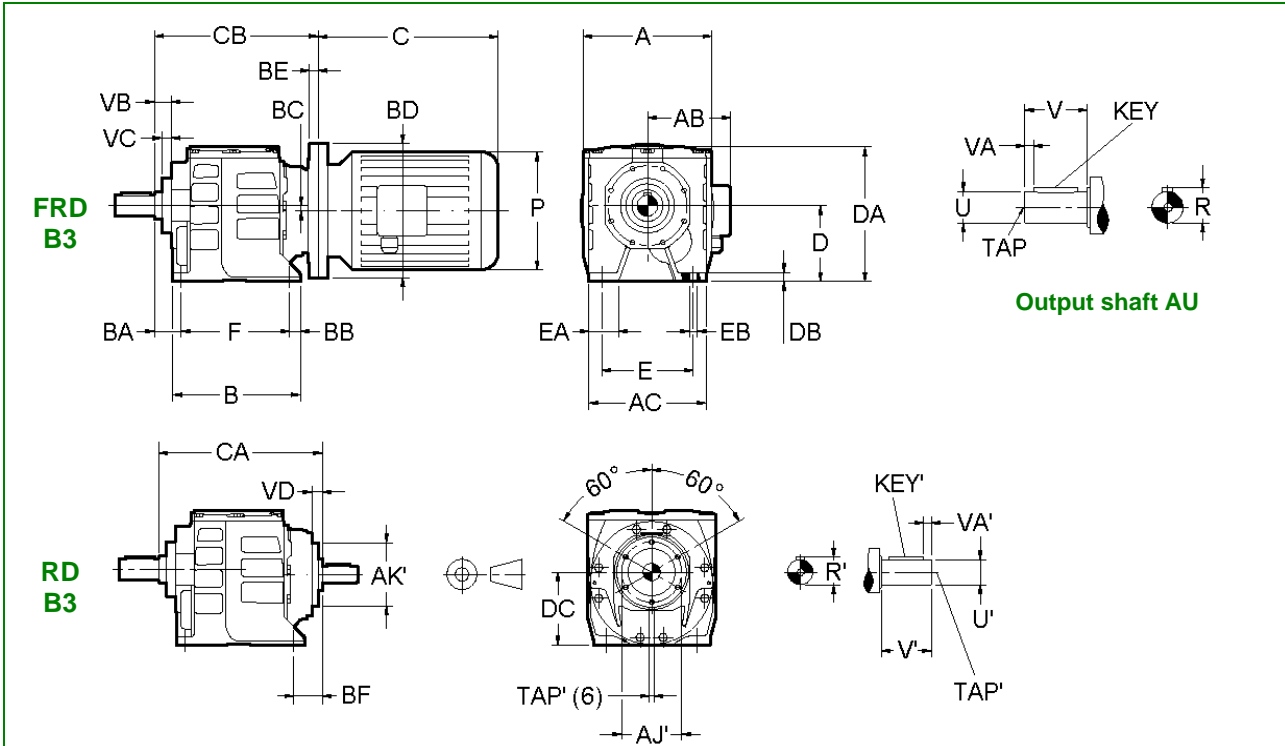

Gear-case flange input	A	AC	B	BA	BB	BC	CB	D	DA	DB	E	EA	EB ∅	F	VB	VC
FRD 02 - 03	3.94	3.78	4.53	0.81	0.43	0.18	6.10	2.36	4.37	0.26	3.15	0.91	0.35	3.74	0.39	0.35
	100	96	115	20.5	11	4.5	155	60	111	6.5	80	23	9	95	10	9

Note: CB: max. length with the biggest input flange
 AB, BD, C, P: according to specific motor manufacturer dimensions

Output shaft	R	U ∅ h6	V	VA	KEY	TAP	
AU 0.625 imperial	0.705	0.625	1.38	0.20	$\frac{3}{16} \times \frac{3}{16} \times 1 \frac{1}{16}$	$\frac{1}{4} - 20 \times 0.63$	Standard Imperial
AU 17 metric	0.75	0.67	1.38	0.20	---	---	Standard Metric
	19	17	35	5	5 x 5 x 25	M6 x 16	
AU 20 metric	0.89	0.79	1.57	0.20	---	---	Optional Metric
	22.5	20	40	5	6 x 6 x 30	M6 x 16	

Gear-case shaft input	AJ'	AK' ∅ g6	BF RD02	BF RD03	CA RD02	CA RD03	DC	R'	U' ∅ h6	V'	VA'	VD	KEY'	TAP'
RD 02 - 03	2.36	2.05	0.98	1.10	5.51	5.63	2.19	0.49	0.43	0.91	0.16	2.36	---	---
	60	52	25	28	140	143	55.5	12.5	11	23	4	13	4 x 4 x 15	M5 x 12.5

Dimensions are inch / mm

RD02 & RD03

Helical Gearboxes RD

FLANGE MOUNTING

DIMENSIONS

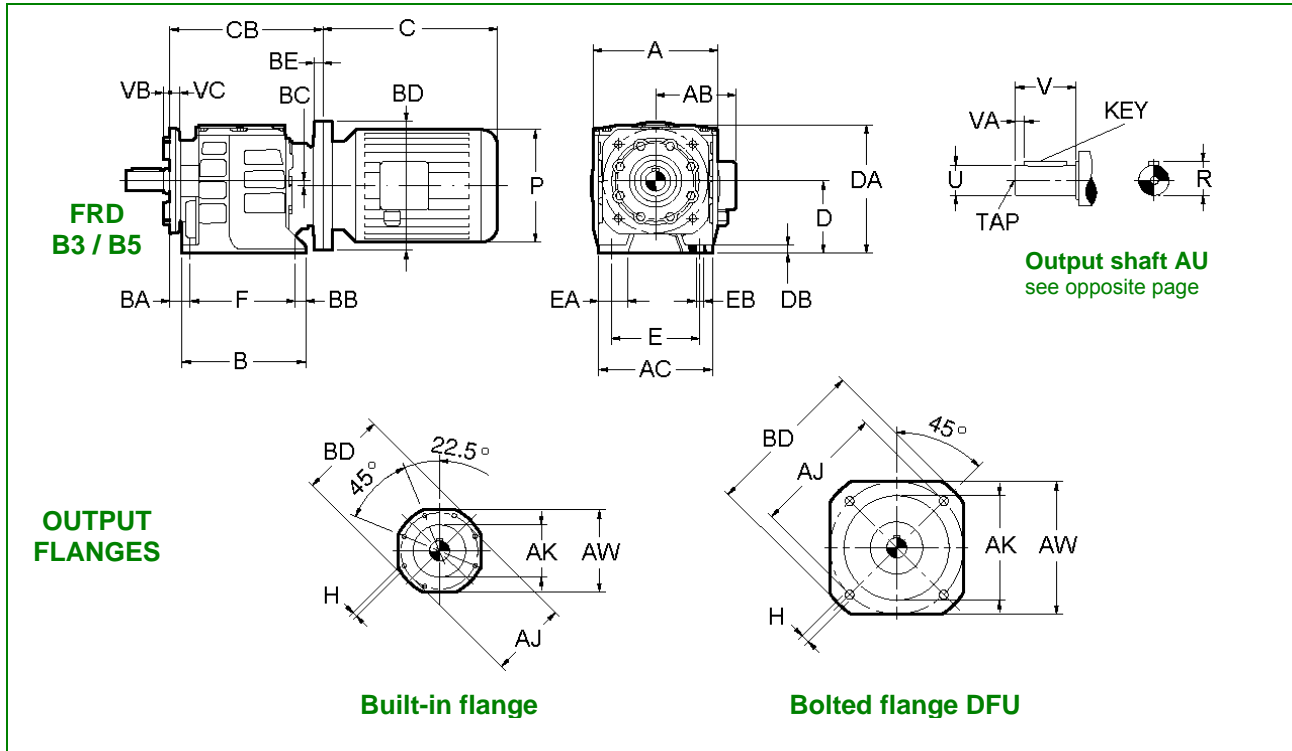

Gear-case	A	AC	B	BA	BB	BC	CB	D	DA	DB	E	EA	EB ∅	F	VB	VC
FRD 02 - 03	3.94	3.78	4.53	1.18	0.43	0.18	6.10	2.36	4.37	0.26	3.15	0.91	0.35	3.74	0.12	0.39
	100	96	115	20.5	11	4.5	155	60	111	6.5	80	23	9	95	3	10

Note: CB: max. length with the biggest input flange
 AB, BD, C, P: according to specific motor manufacturer dimensions

Output flange	AJ	AK	AW □	BD	H thread / bore
Built-in flange	2.95 75	2.36 60 _{g6}	3.23 82	3.39 84	--- M6 x 14 (7)
DFU120	3.94 100	3.15 80 _{h7}	3.94 100	4.72 120	∅ 0.28 (4) ∅ 7 (4)
DFU140	4.63 115	3.74 95 _{h7}	4.53 115	5.51 140	∅ 0.35 (4) ∅ 9 (4)
DFU160	6.12 130	4.33 110 _{h7}	6.12 130	6.30 160	∅ 0.35 (4) ∅ 9 (4)

Dimensions are inch / mm

Helical Gearboxes RD

RD12 & RD13

DIMENSIONS

FOOT MOUNTING

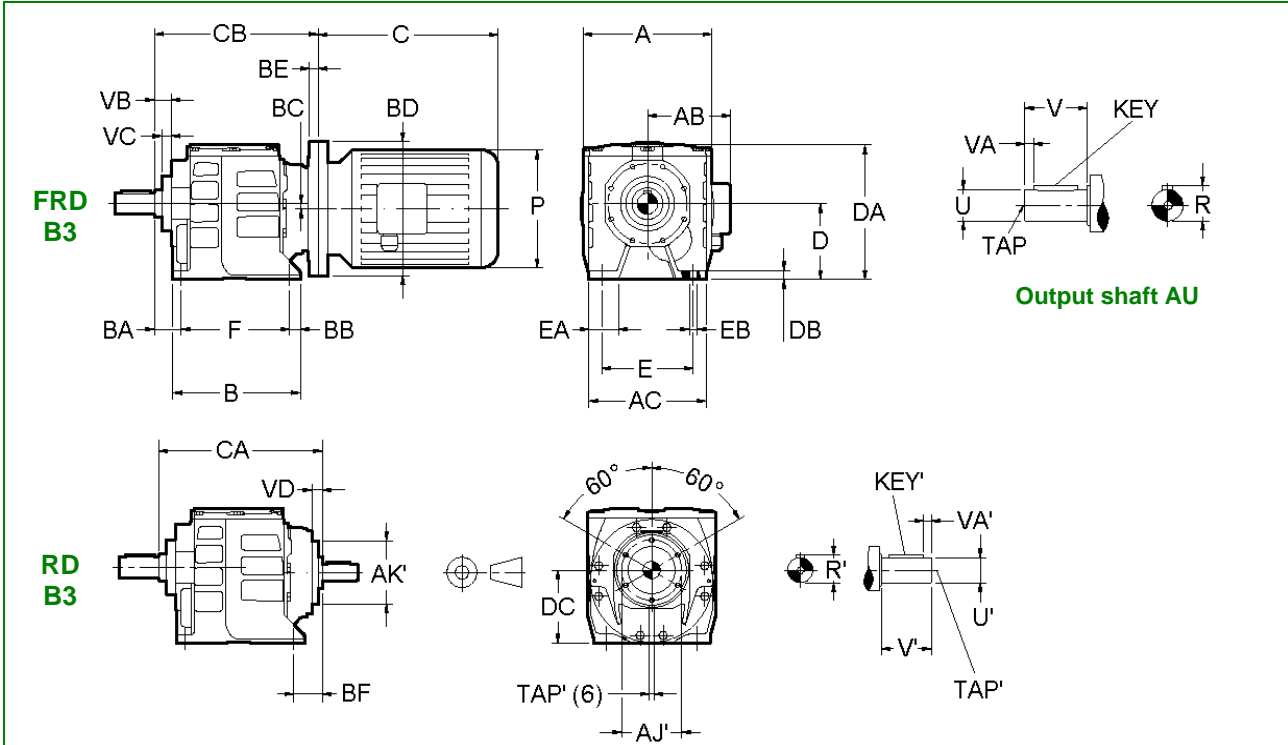

Gear-case flange input	A	AC	B	BA	BB	BC	CB	D	DA	DB	E	EA	EB ∅	F	VB	VC
FRD12 - 13	5.51	5.31	5.20	0.71	0.45	0.20	6.89	2.95	5.17	0.31	4.33	1.50	0.35	4.33	0.39	0.35
	140	135	132	18	11.5	5	175	75	131	8	110	38	9	110	10	9

Note: CB: max. length with the biggest input flange
 AB, BD, C, P: according to specific motor manufacturer dimensions

Output shaft	R	U ∅ h6	V	VA	KEY	TAP	
AU 0.75 imperial	0.83	0.75	1.57	0.25	$\frac{3}{16} \times \frac{3}{16} \times 1 \frac{1}{16}$	$\frac{1}{4} - 20 \times 0.63$	Standard Imperial
AU 20 metric	0.89	0.79	1.57	0.20	---	---	Standard Metric
	22.5	20	40	5	6 x 6 x 30	M6 x 16	
AU 25 metric	1.10	0.98	1.97	0.20	---	---	Optional Metric
	28	25	50	5	8 x 7 x 40	M6 x 16	

Gear-case shaft input	AJ'	AK' ∅ g6	BF RD12	BF RD13	CA RD12	CA RD13	DC	R'	U' ∅ h6	V'	VA'	VD	KEY'	TAP'
RD12 - 13	2.76	2.36	0.91	1.30	5.94	6.34	2.76	0.63	0.55	1.18	0.10	0.51	---	---
	70	60	23	33	151	161	70	16	14	30	2.5	13	5 x 5 x 25	M6 x 12

Dimensions are inch / mm

RD12 & RD13

Helical Gearboxes RD

FLANGE MOUNTING

DIMENSIONS

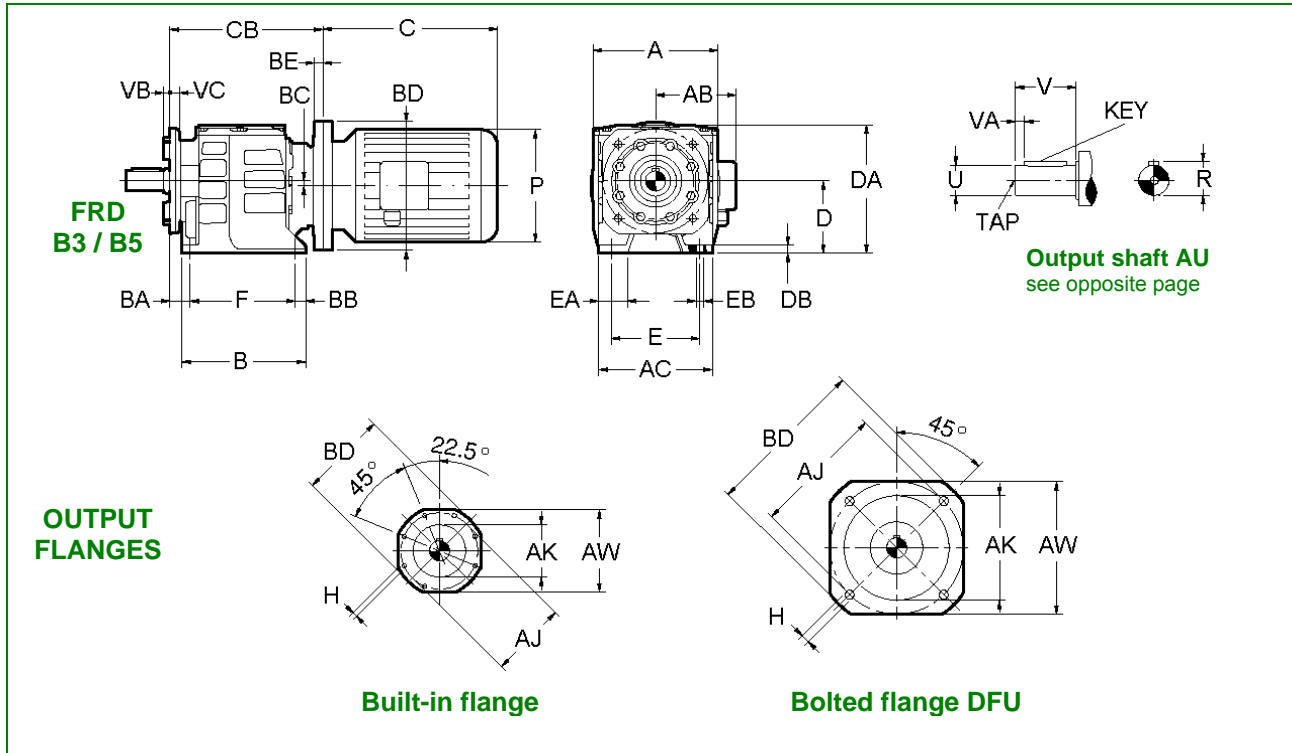

Gear-case	A	AC	B	BA	BB	BC	CB	D	DA	DB	E	EA	EB ∅	F	VB	VC
FRD12 - 13	5.51	5.31	5.20	0.71	0.45	0.20	6.89	2.95	5.16	0.31	4.33	1.50	0.35	4.33	0.12	0.35
	140	135	132	18	11.5	5	175	75	131	8	110	38	9	110	3	9

Note: CB: max. length with the biggest input flange
 AB, BD, C, P: according to specific motor manufacturer dimensions

Output flange	AJ	AK	AW □	BD	H thread / bore
Built-in flange	2.95 75	2.24 60 _{g6}	3.23 82	3.31 84	--- M6 x 14 (7)
DFU120	3.94 100	3.15 80 _{h7}	3.94 100	4.72 120	∅ 0.28 (4) ∅ 7 (4)
DFU140	4.53 115	3.74 95 _{h7}	4.53 115	5.51 140	∅ 0.35 (4) ∅ 9 (4)
DFU160	6.12 130	4.33 110 _{h7}	5.12 130	6.30 160	∅ 0.35 (4) ∅ 9 (4)

Dimensions are inch / mm

Helical Gearboxes RD

RD22 & RD23

DIMENSIONS

FOOT MOUNTING

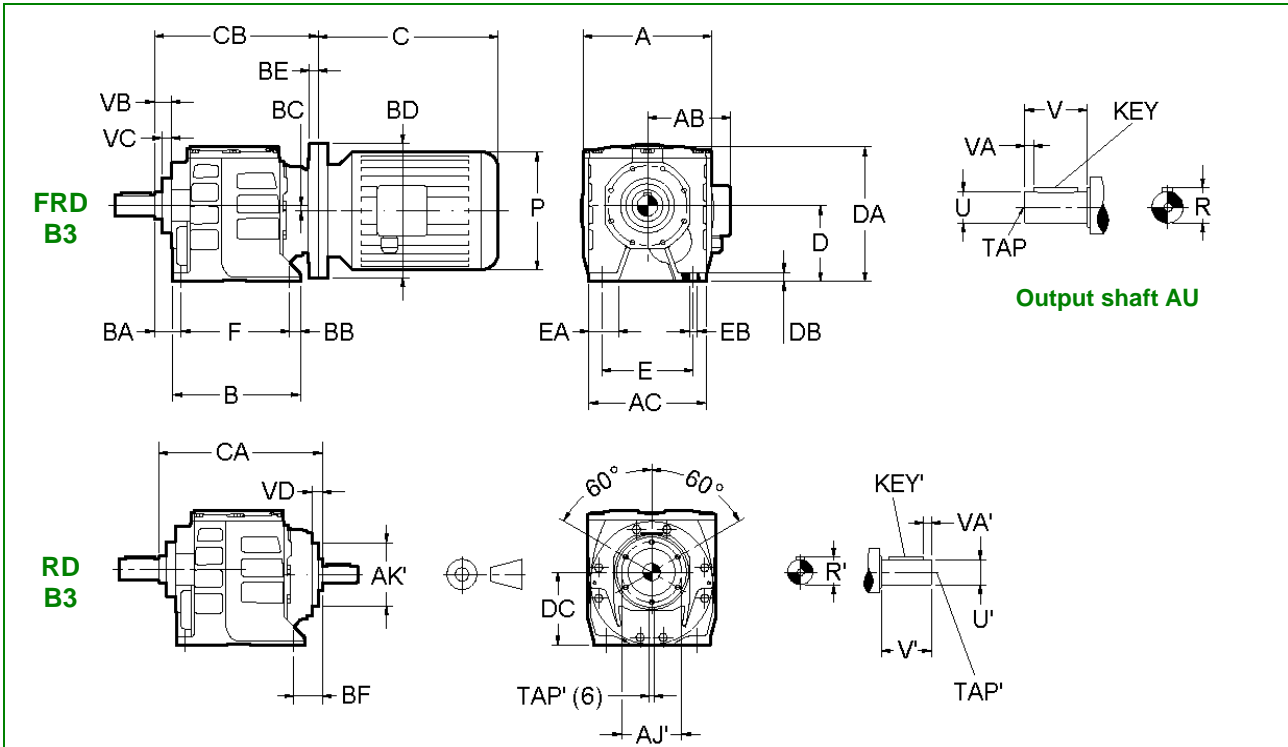

Gear-case flange input	A	AC	B	BA	BB	BC	CB	D	DA	DB	E	EA	EB ø	F	VB	VC
FRD 22 - 23	6.10	5.51	6.02	0.98	0.51	0.24	8.58	3.54	6.22	0.39	4.33	1.46	0.35	5.12	0.51	0.43
	155	140	153	25	13	6	218	90	158	10	110	37	9	130	13	11

Note: CB: max. length with the biggest input flange
 AB, BD, C, P: according to specific motor manufacturer dimensions

Output shaft	R	U ø h6	V	VA	KEY	TAP	
AU 1.0 imperial	1.11	1.0	1.97	0.26	$1/4 \times 1/4 \times 1^{5/16}$	$3/8 - 16 \times 0.87$	Standard Imperial
AU 25 metric	1.10	0.98	1.97	0.30	---	---	Standard Metric
AU 30 metric	1.30	1.18	2.36	0.39	---	---	Optional Metric
	33	30	60	10	8 x 7 x 40	M10 x 22	

Gear-case shaft input	AJ'	AK' ø g6	BF RD22	BF RD23	CA RD22	CA RD23	DC	R'	U' ø h6	V'	VA'	VD	KEY'	TAP'
RD 22 - 23	3.35	2.76	1.38	2.09	7.48	8.19	3.31	0.85	0.75	1.57	0.20	0.61	---	---
	85	70	35	53	190	208	84	21.5	19	40	5	15.5	5 x 5 x 30	M8 x 10

Dimensions are inch / mm

RD22 & RD23

Helical Gearboxes RD

FLANGE MOUNTING

DIMENSIONS

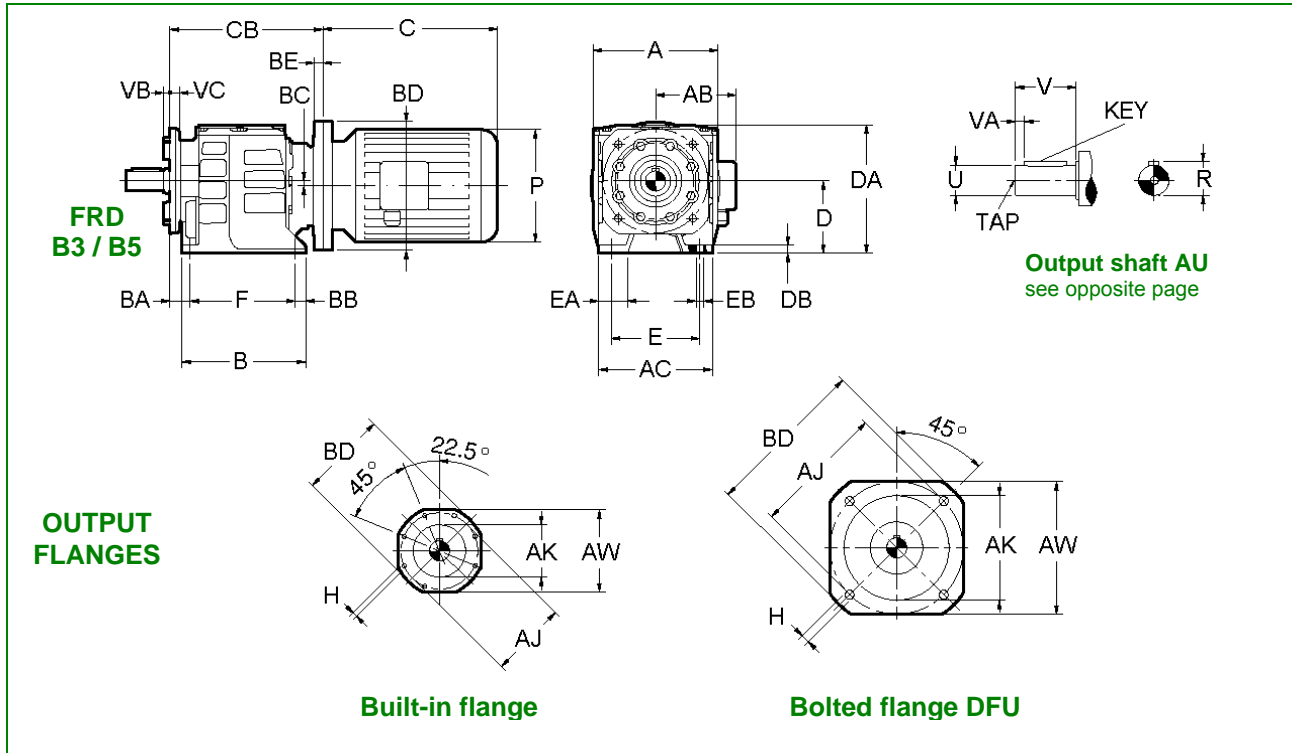

Gear-case	A	AC	B	BA	BB	BC	CB	D	DA	DB	E	EA	EB ∅	F	VB	VC
FRD 22 - 23	6.10	5.51	6.02	0.98	0.51	0.24	8.58	3.54	6.22	0.39	4.33	1.46	0.35	5.12	0.12	0.47
	155	140	153	25	13	6	218	90	158	10	110	37	9	130	3	12

Note: CB: max. length with the biggest input flange
 AB, BD, C, P: according to specific motor manufacturer dimensions

Output flange	AJ	AK	AW □	BD	H thread / bore
Built-in flange	3.75 95	2.56 65 _{g6}	4.02 102	4.25 108	--- M6 x 10 (8)
DFU140	4.53 115	3.75 95 _{h7}	4.53 115	5.51 140	∅ 0.35 (4) ∅ 9 (4)
DFU160	5.12 130	4.33 110 _{h7}	5.12 130	6.30 160	∅ 0.35 (4) ∅ 9 (4)
DFU 200	6.50 165	5.12 130 _{h7}	6.50 165	7.87 200	∅ 0.43 (4) ∅ 11 (4)

Dimensions are inch / mm

Helical Gearboxes RD

RD32 & RD33

DIMENSIONS

FOOT MOUNTING

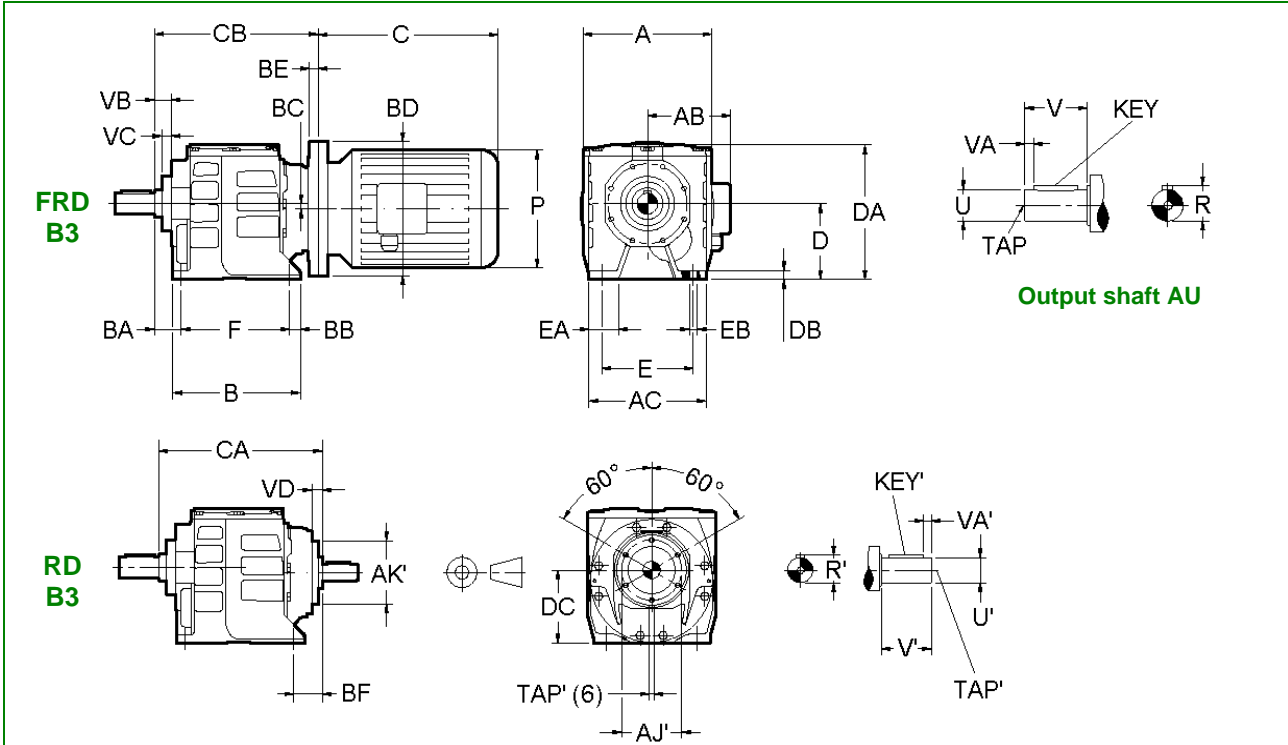

Gear-case flange input	A	AC	B	BA	BB	BC	CB	D	DA	DB	E	EA	EB ø	F	VB	VC
FRD 32 - 33	7.48	6.81	7.68	1.18	0.59	0.33	10.31	4.53	7.80	0.55	5.31	1.73	0.45	6.50	0.51	0.43
	190	173	195	30	15	8.5	262	115	198	14	135	44	11.5	165	13	11

Note: CB: max. length with the biggest input flange
AB, BD, C, P: according to specific motor manufacturer dimensions

Output shaft	R	U ø h6	V	VA	KEY	TAP	
AU 1.25 imperial	1.36	1.25	2.36	0.26	$1/4 \times 1/4 \times 1 1/16$	$1/2 - 13 \times 1.12$	Standard Imperial
AU 30 metric	1.30	1.18	2.36	0.39	---	---	Standard Metric
	33	30	60	10	8 x 7 x 40	M10 x 22	
AU 35 metric	1.50	1.38	2.76	0.39	---	---	Optional Metric
	38	35	70	10	10 x 8 x 50	M10 x 22	

Gear-case shaft input	AJ'	AK' ø g6	BF RD32	BF RD33	CA RD32	CA RD33	DC	R'	U' ø h6	V'	VA'	VD	KEY'	TAP'
RD 32 - 33	3.35	2.76	0.98	2.28	8.98	9.96	4.19	1.06	0.94	1.97	0.20	0.61	---	---
	85	70	25	58	228	253	106.5	27	24	50	5	15.5	8 x 7 x 40	M8 x 15

Dimensions are inch / mm

RD32 & RD33

Helical Gearboxes RD

FLANGE MOUNTING

DIMENSIONS

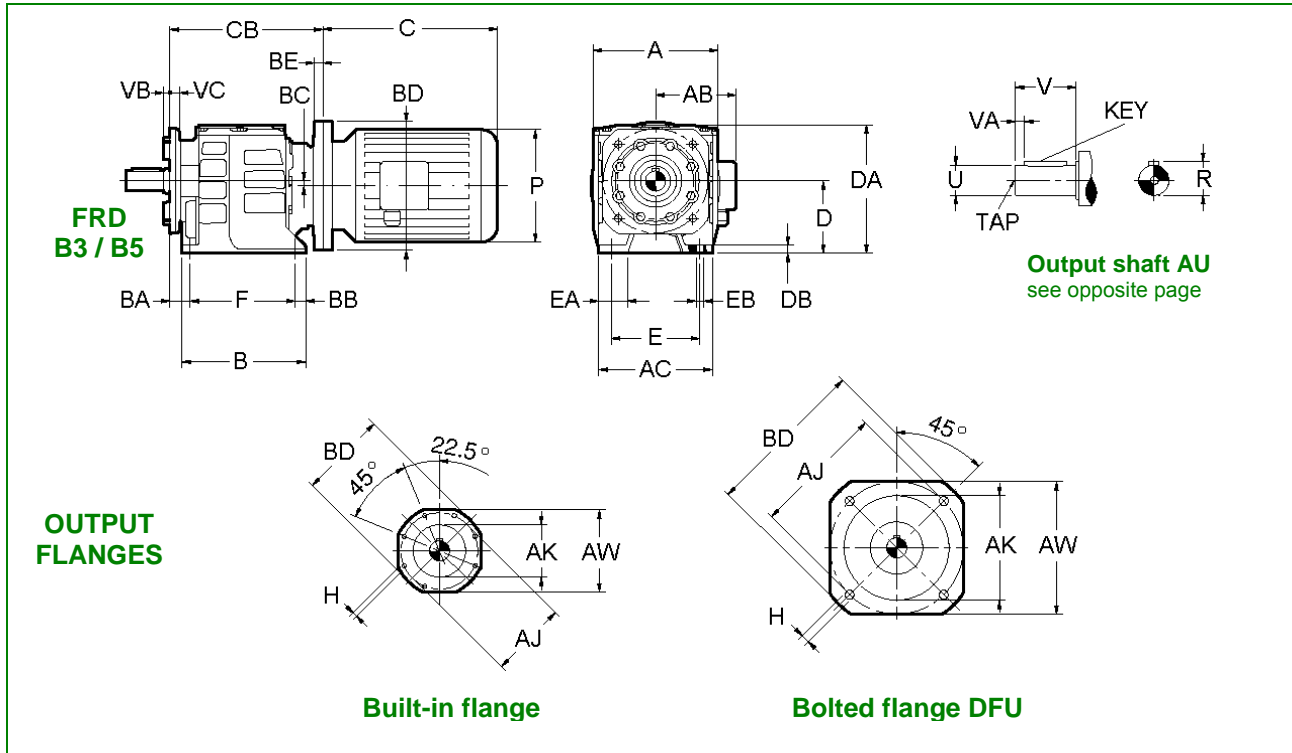

Gear-case	A	AC	B	BA	BB	BC	CB	D	DA	DB	E	EA	EB ∅	F	VB	VC
FRD 32 - 33	7.48	6.81	7.68	1.18	0.59	0.33	10.31	4.53	7.80	0.55	5.31	1.73	0.45	6.50	0.14	0.47
	190	173	195	30	15	8.5	262	115	198	14	135	44	11.5	165	3.5	12

Note: CB: max. length with the biggest input flange
 AB, BD, C, P: according to specific motor manufacturer dimensions

Output flange	AJ	AK	AW □	BD	H thread / bore
Built-in flange	4.53 115	3.35 85_{g6}	4.92 125	4.72 130	--- M8 x 18 (8)
DFU160	5.12 130	4.33 110_{h7}	5.31 135	6.30 160	∅ 0.35 (4) ∅ 9 (4)
DFU 200	6.50 165	5.12 130_{h7}	6.50 165	7.87 200	∅ 0.43 (4) ∅ 11 (4)
DFU 250	8.47 215	7.09 180_{h7}	8.47 215	9.84 250	∅ 0.51 (4) ∅ 13 (4)

Dimensions are inch / mm

Helical Gearboxes RD

RD42 & RD43

DIMENSIONS

FOOT MOUNTING

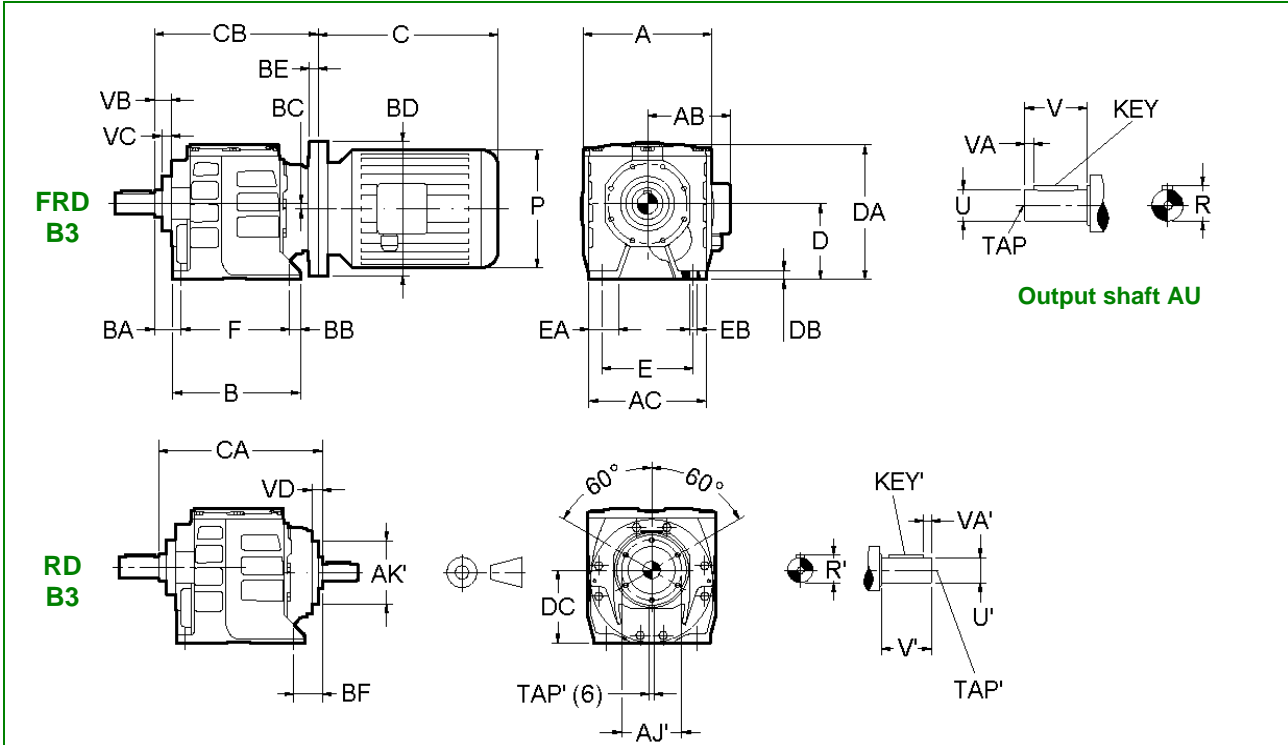

Gear-case flange input	A	AC	B	BA	BB	BC	CB	D	DA	DB	E	EA	EB ø	F	VB	VC
FRD 42 - 43	8.46	7.68	8.70	1.18	0.51	0.37	13.03	5.12	8.74	0.59	5.91	1.97	0.53	7.68	0.59	0.51
	215	195	221	30	13	9.5	331	130	222	15	150	50	13.5	195	15	13

Note: CB: max. length with the biggest input flange
 AB, BD, C, P: according to specific motor manufacturer dimensions

Output shaft	R	U ø h6	V	VA	KEY	TAP	
AU 1.375 imperial	1.51	1.375	2.76	0.34	$\frac{5}{16} \times \frac{5}{16} \times 1 \frac{13}{16}$	$\frac{1}{2} - 13 \times 1.12$	Standard Imperial
AU 35 metric	1.50	1.38	2.76	0.39	---	---	Standard Metric
	38	35	70	10	10 x 8 x 50	M12 x 28	
AU 40 metric	1.69	1.57	3.15	0.39	---	---	Optional Metric
	43	40	80	10	12 x 8 x 60	M12 x 28	

Gear-case shaft input	AJ'	AK' ø g6	BF RD42	BF RD43	CA RD42	CA RD43	DC	R'	U' ø h6	V'	VA'	VD	KEY'	TAP'
RD 42 - 43	3.94	3.15	1.57	3.15	10.43	12.01	4.74	1.23	1.10	2.36	0.20	0.61	---	---
	100	80	40	80	265	305	120.5	31	28	60	5	15.5	8 x 7 x 50	M8 x 16

Dimensions are inch / mm

RD42 & RD43

Helical Gearboxes RD

FLANGE MOUNTING

DIMENSIONS

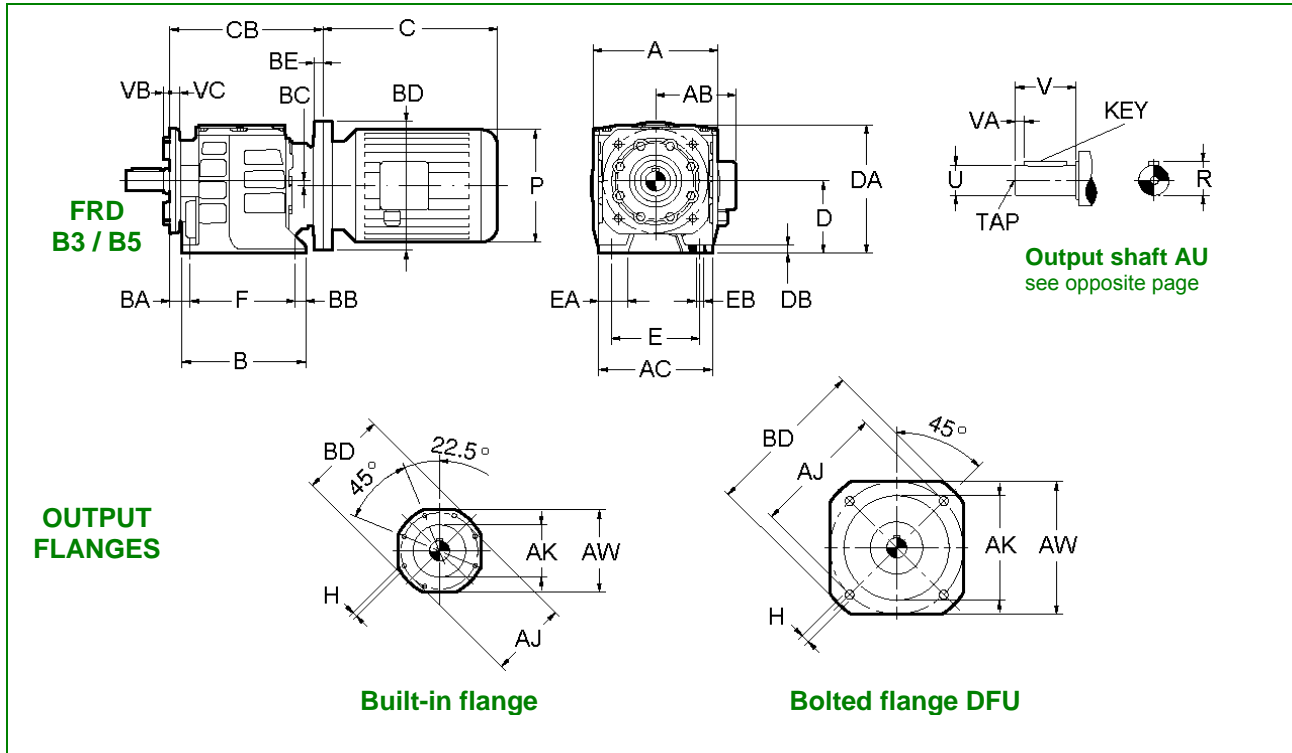

Gear-case	A	AC	B	BA	BB	BC	CB	D	DA	DB	E	EA	EB ∅	F	VB	VC
FRD 42 - 43	8.46	7.68	8.70	1.18	0.51	0.37	13.03	5.12	8.74	0.59	5.91	1.97	0.53	7.68	0.16	0.55
	215	195	221	30	13	9.5	331	130	222	15	150	50	13.5	195	4	14

Note: CB: max. length with the biggest input flange
 AB, BD, C, P: according to specific motor manufacturer dimensions

Output flange	AJ	AK	AW □	BD	H thread / bore
Built-in flange	5.12 130	3.74 95 _{g6}	5.60 142	5.71 145	--- M8 x 18 (8)
DFU200	6.50 165	5.12 130 _{h7}	6.50 165	7.87 200	∅ 0.43 (4) ∅ 11 (4)
DFU250	8.46 215	7.09 180 _{h7}	8.46 215	9.84 250	∅ 0.53 (4) ∅ 13.5 (4)
DFU 300	10.43 265	9.06 230 _{h7}	10.43 265	11.81 300	∅ 0.66 (4) ∅ 17 (4)

Dimensions are inch / mm

Helical Gearboxes RD

RD52 & RD53

DIMENSIONS

FOOT MOUNTING

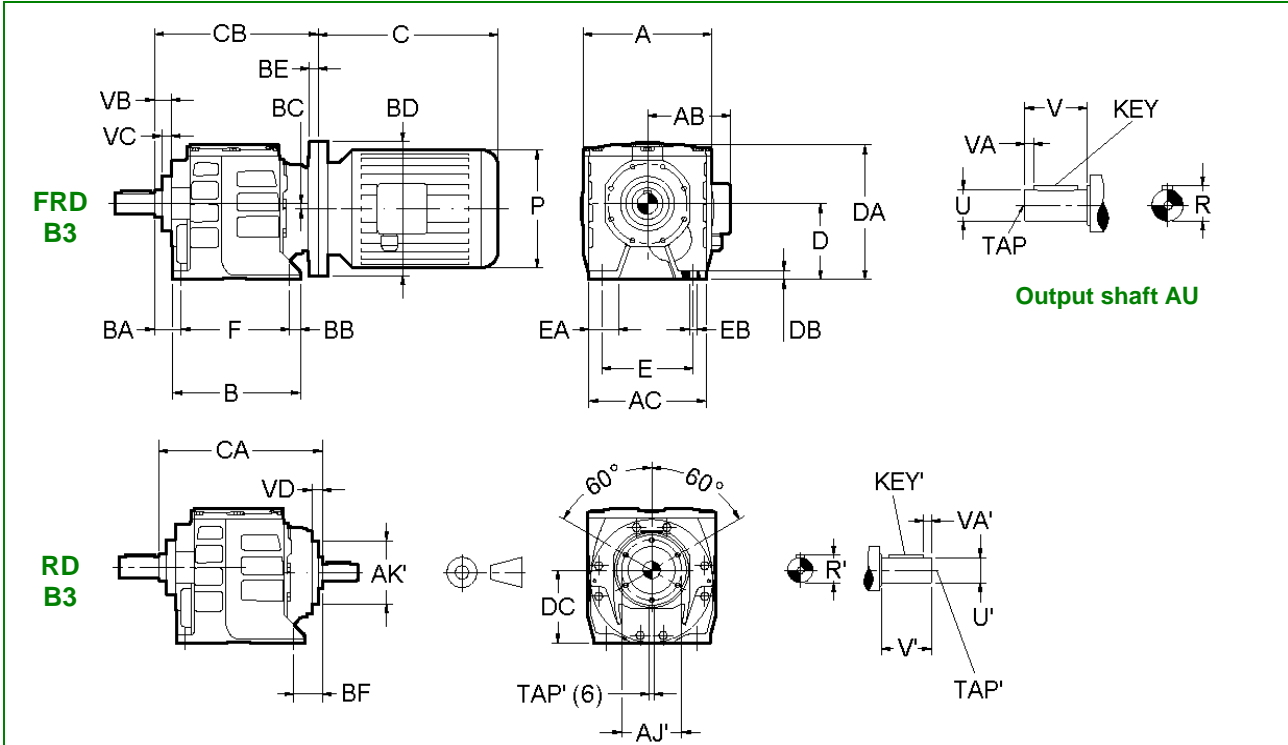

Gear-case flange input	A	AC	B	BA	BB	BC	CB	D	DA	DB	E	EA	EB ∅	F	VB	VC
FRD 52 - 53	11.18	10.0	10.0	1.38	0.71	0	13.9	5.51	10.04	0.79	6.69	3.03	0.71	8.07	0.71	0.55
	284	254	254	35	18	0	353	140	255	20	170	77	18	205	18	14

Note: CB: max. length with the biggest input flange
 AB, BD, C, P: according to specific motor manufacturer dimensions

Output shaft	R	U ∅ h6	V	VA	KEY	TAP	
AU 1.625 imperial	1.79	1.625	3.15	0.38	$\frac{3}{8} \times \frac{3}{8} \times 2 \frac{1}{4}$	$\frac{5}{8} - 11 \times 1.38$	Standard Imperial
AU 40 metric	1.69	1.57	3.15	0.39	---	---	Standard Metric
	43	40	80	10	12 x 8 x 60	M12 x 28	
AU 50 metric	2.11	1.97	3.94	0.20	---	---	Optional Metric
	53.5	50	100	5	14 x 9 x 90	M16 x 36	

Gear-case shaft input	AJ'	AK' ∅ g6	BF	---	CA RD52	CA RD53	DC	R'	U' ∅ h6	V'	VA'	VD	KEY'	TAP'
RD 52 - 53	5.51	4.72	3.22	---	12.68	12.68	5.51	1.61	1.50	3.15	0.39	0.87	---	---
	140	120	82	---	322	322	140	41	38	80	10	22	10 x 8 x 60	M12 x 28

Dimensions are inch / mm

RD52 & RD53

Helical Gearboxes RD

FLANGE MOUNTING

DIMENSIONS

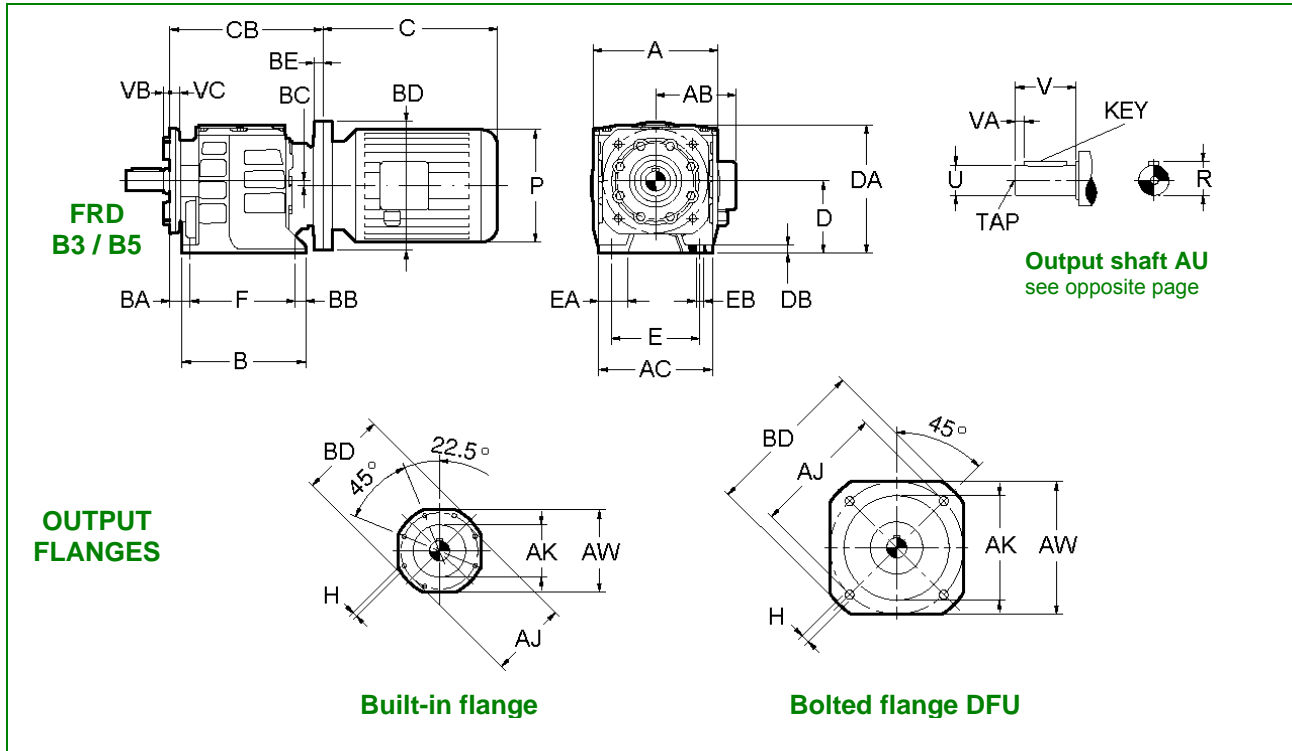

Gear-case	A	AC	B	BA	BB	BC	CB	D	DA	DB	E	EA	EB ∅	F	VB	VC
FRD 52 - 53	11.18	10.0	10.0	1.38	0.71	0	13.9	5.51	10.04	0.79	6.69	3.03	0.71	8.07	0.16	0.67
	284	254	254	35	18	0	353	140	255	20	170	77	18	205	4	17

Note: CB: max. length with the biggest input flange
 AB, BD, C, P: according to specific motor manufacturer dimensions

Output flange	AJ	AK	AW □	BD	H thread / bore
Built-in flange	6.50 165	5.12 130	7.09 180	7.48 190	--- M10 x 25 (8)
DFU 250	8.46 215	7.09 180	8.46 215	9.84 250	∅ 0.53 (4) ∅ 13.5 (4)
DFU 300	10.43 265	9.06 230	10.43 265	11.81 300	∅ 0.69 (4) ∅ 17.5 (4)
DFU 350	11.81 300	9.84 250	11.81 300	13.78 350	∅ 0.69 (4) ∅ 17.5 (4)

Dimensions are inch / mm

Helical Gearboxes RD

RD62 & RD63

DIMENSIONS

FOOT MOUNTING

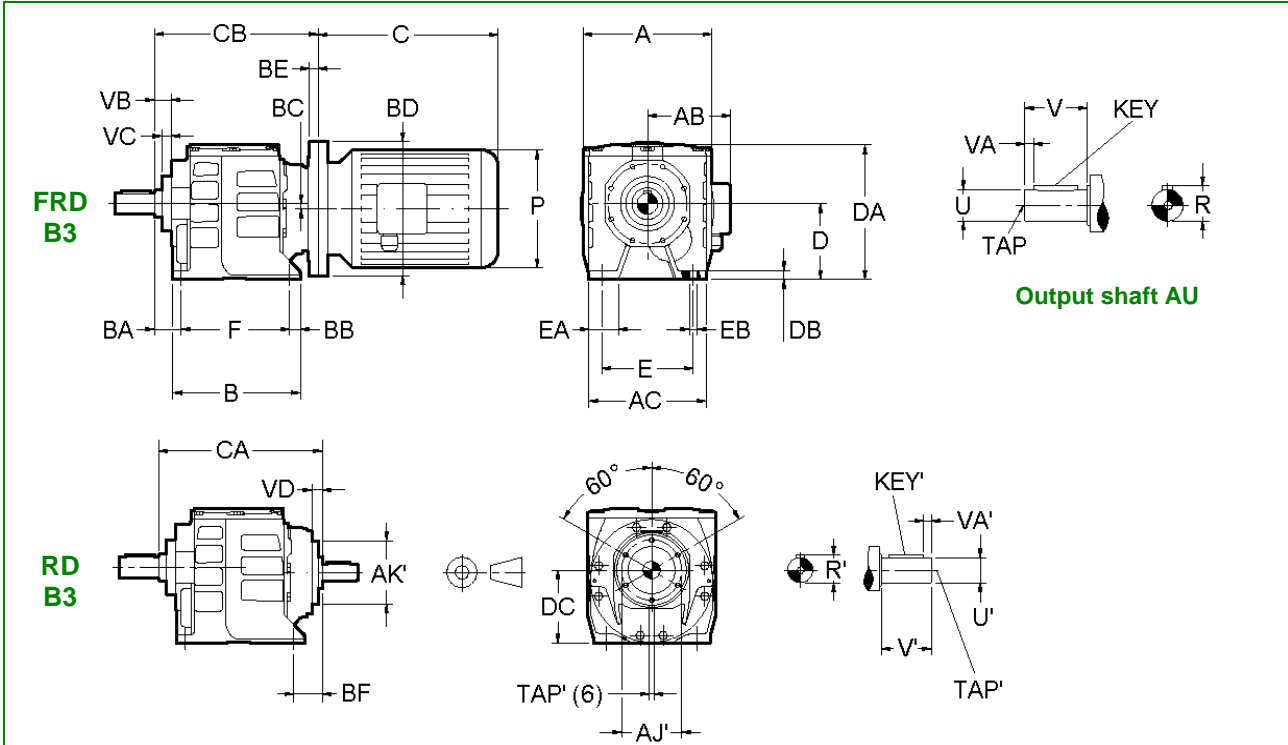

Gear-case flange input	A	AC	B	BA	BB	BC	CB	D	DA	DB	E	EA	EB ø	F	VB	VC
FRD 62 - 63	13.39	11.81	12.01	1.57	1.02	0	16.14	7.09	11.89	0.94	8.46	3.23	0.71	10.24	0.71	0.55
	340	300	305	40	26	0	410	180	302	24	215	82	18	260	18	14

Note: CB: max. length with the biggest input flange
 AB, BD, C, P: according to specific motor manufacturer dimensions

Output shaft	R	U ø h6	V	VA	KEY	TAP	
AU 2.125 imperial	2.35	2.125	3.94	0.64	$1/2 \times 1/2 \times 2^{5/8}$	$3/4 - 101 \times 1.61$	Standard Imperial
AU 50 metric	2.11	1.97	3.94	0.20	---	---	Standard Metric
AU 60 metric	2.52	2.36	4.72	0.20	---	---	Optional Metric
	64	60	120	5	18 x 11 x 110	M20 x 42	

Gear-case shaft input	AJ'	AK' ø g6	BF	---	CA RD62	CA RD63	DC	R'	U' ø h6	V'	VA'	VD	KEY'	TAP'
RD 62 - 63	5.51	4.72	3.12	---	14.92	14.92	7.09	2.03	1.89	3.94	0.39	0.87	---	---
	140	120	79	---	379	379	180	51.5	48	100	10	22	14 x 9 x 80	M16 x 36

Dimensions are inch / mm

RD62 & RD63

Helical Gearboxes RD

FLANGE MOUNTING

DIMENSIONS

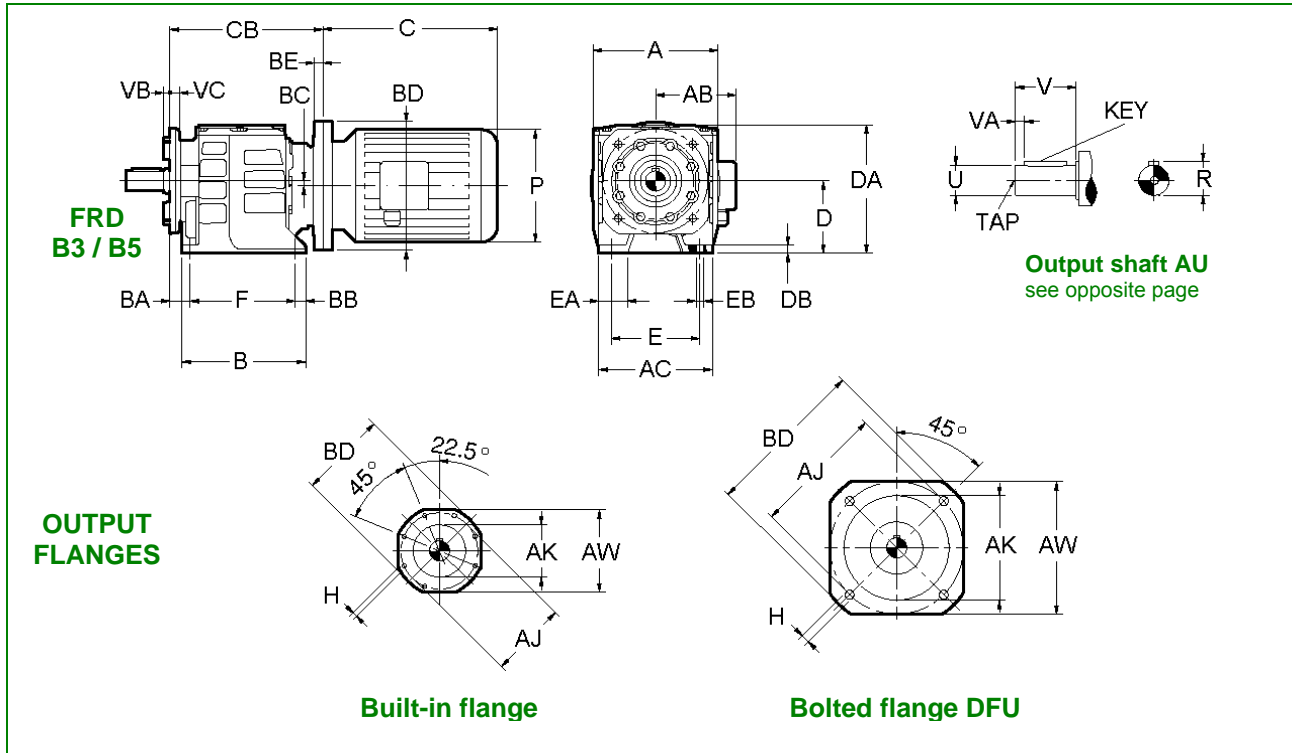

Gear-case	A	AC	B	BA	BB	BC	CB	D	DA	DB	E	EA	EB ∅	F	VB	VC
FRD 62 - 63	13.39	11.81	12.01	1.57	1.02	0	16.14	7.09	11.89	0.94	8.46	3.23	0.71	10.24	0.16	0.67
	340	300	305	40	26	0	410	180	302	24	215	82	18	260	4	17

Note: CB: max. length with the biggest input flange
AB, BD, C, P: according to specific motor manufacturer dimensions

Output flange	AJ	AK	AW □	BD	H thread / bore
Built-in flange	6.50 165	5.12 130	7.09 180	7.48 190	--- M10 x 25 (8)
DFU 250	8.46 215	7.09 180	8.46 215	9.84 250	∅ 0.53 (4) ∅ 13.5 (4)
DFU 300	10.43 265	9.06 230	10.43 265	11.81 300	∅ 0.69 (4) ∅ 17.5 (4)
DFU 350	11.81 300	9.84 250	11.81 300	13.78 350	∅ 0.69 (4) ∅ 17.5 (4)

Dimensions are inch / mm

Helical Gearboxes RD

SUMMARY OF OPERATION AND MAINTENANCE INSTRUCTIONS

Variable speed and reduction gearboxes are not part of the field of application of the Machinery Directive, art.1(2), and they must not be put into service until the machinery into which they are to be incorporated, has been declared in conformity with the provision of art. 4(2), annex II(B) of Machinery Directives 98/37/CEE/22.6.98 and for Italy only, of DL 459/24.7.96.

Installation

Check if the unit to be installed, is properly selected to perform the required function and that its mounting position complies with the order.

The nameplate reports such information.

Check mounting stability to ensure the unit runs without vibrations or overloads.

Running

The unit may be connected for clockwise or counter-clockwise rotation.

The unit must be stopped as soon as defective running or unexpected noise occur, remove the faulty part or return the unit to the factory for checking.

If the faulty part is not replaced, other parts can also be affected, causing more severe damage and making the identification of initial cause more difficult.

Maintenance

Although the units are no-load run tested in the factory before despatch, it is recommended not to run them at maximum load for the first 20-30 running hours to allow the proper running in.

The gearboxes are delivered already filled with long-life synthetic oil and, in case of replacement or topping, do not mix with mineral lubricants.

Handling

When hoisting, use relevant housing locations or eyebolts if provided, or foot or flange holes.

Never hoist on any moving part.

Painting

Carefully protect oil seals, coupling faces and shafts when units are re-painted.

Long-term storage

For storage longer than 3 months, apply antioxidants onto shafts and machined surfaces, and protective grease on oil seal lips.

Product's Environmental Management

In conformity with Environmental Certification ISO 14001, we recommend the following to dispose of our products:

- scraped components of the units to be delivered to authorized centres for metal object collection;
- oils and lubricants drained from the units to be delivered to Exhausted Oil Unions;
- packages (pallets, carton boxes, paper, plastic, etc.) to lead into regeneration/recycling circuits as far as possible, by delivering separate waste classes to authorized companies.

(complete manual on www.varvel.com)



A socially responsible company _____

To the scope of intensifying our commitment to society, Varvel since 2004 started an ongoing support programme with three non-profit institutions: UNICEF (United Nations Children's Fund), MSF (Médecins sans Frontières) and ANT (National Cancer Association). Environmental respect and protection are also part of Varvel's values and this is why Varvel certified in 2001 its Environmental System to standard UNI EN ISO 14001.



RN·RO·RV



RS·RT



RD



RG



VR·VS



ISM·BSM



VARfarm
by VARVEL



VARVEL®
MOTION CONTROL SINCE 1955

DIEQUA
Corporation

180 Covington Drive
Bloomington, IL 60108
630-980-1133 www.diequa.com