

Screw Jack Systems

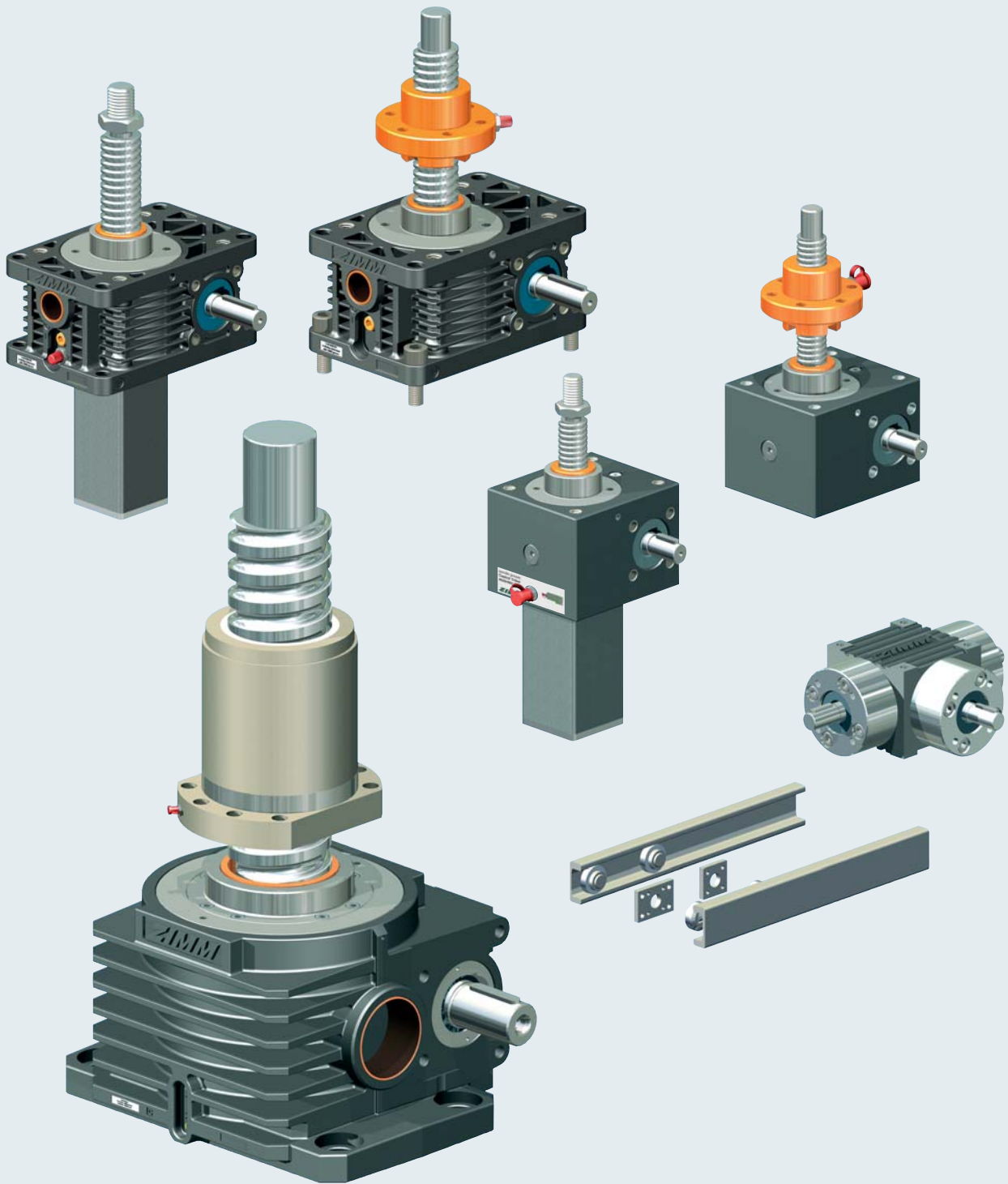

The ZIMM Transmission Parts catalogue and ZIMM Actuators catalogue are available for download from www.zimm.at or on request.

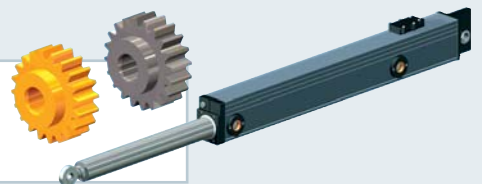

1	Screw jack systems – Overview Modular options – Overview Product features		Product overview
2	Z-Tr trapezoidal screw jacks Z-KGT ball screw jacks Z-SIFA screw jacks with safety nuts		Z series Screw jacks 5 kN to 1,000 kN
3	GSZ-Tr trapezoidal screw jacks GSZ-KGT ball screw jacks GSZ-SIFA screw jacks with safety nuts		GSZ series Screw jacks 2.5 kN to 100 kN
4	Accessories for screw jack systems		Accessories
5	Bevel gearboxes		Bevel gearboxes
6	Linear guides		Linear guides
7	Checklists for enquiries		Checklists
8	Design advice Selection, calculations Operation/Maintenance Special applications and conditions		Technical appendix
9	Example applications		Example applications
10	ZIMM – the company Other products: Transmission Parts, Actuators ZSA Imprint, Copyright, How to reach us General Terms and Conditions, Distributors		About ZIMM, Contacts

Complete solutions from a single source

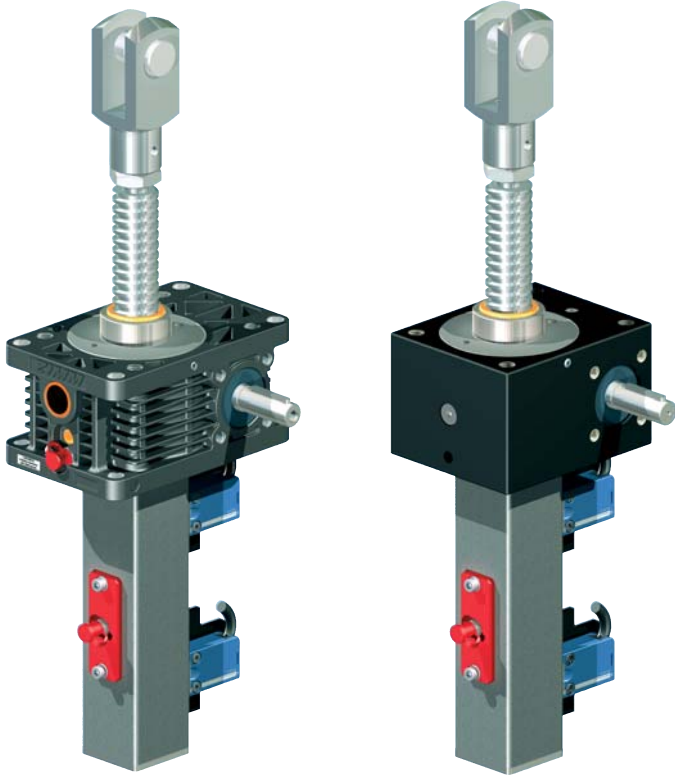

CAD files:
To assist your design process,
CAD files for our components
are available at www.zimm.at

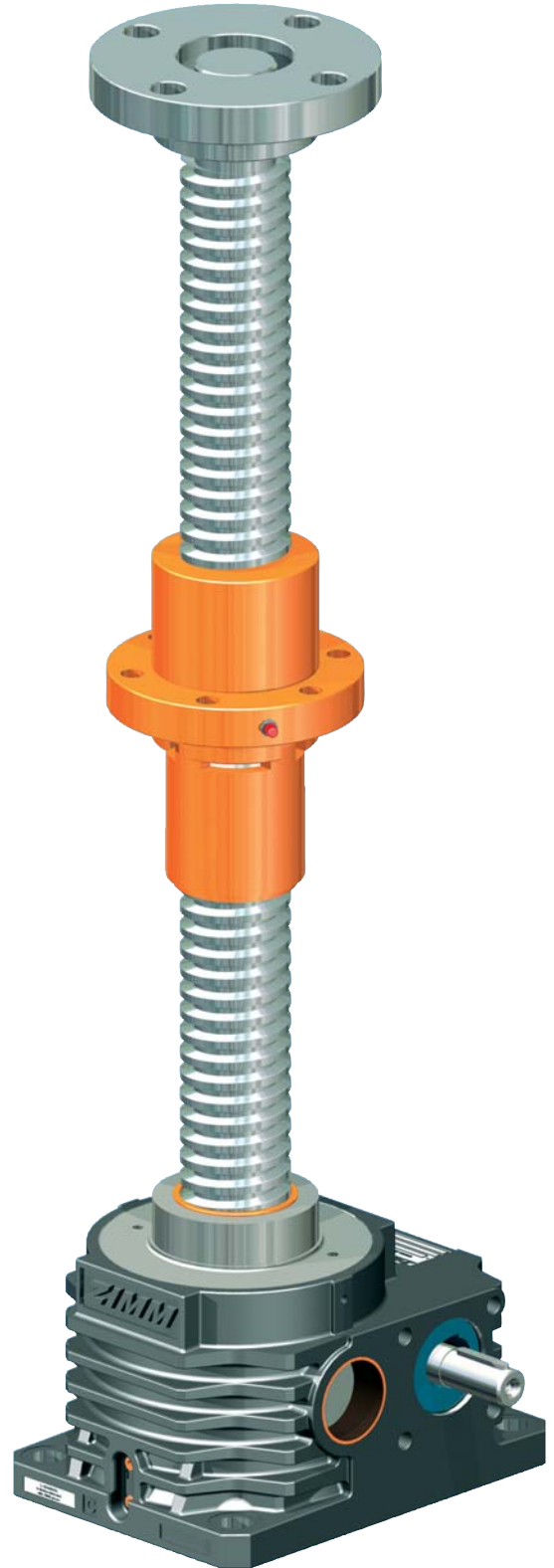

Complete solutions from a single source

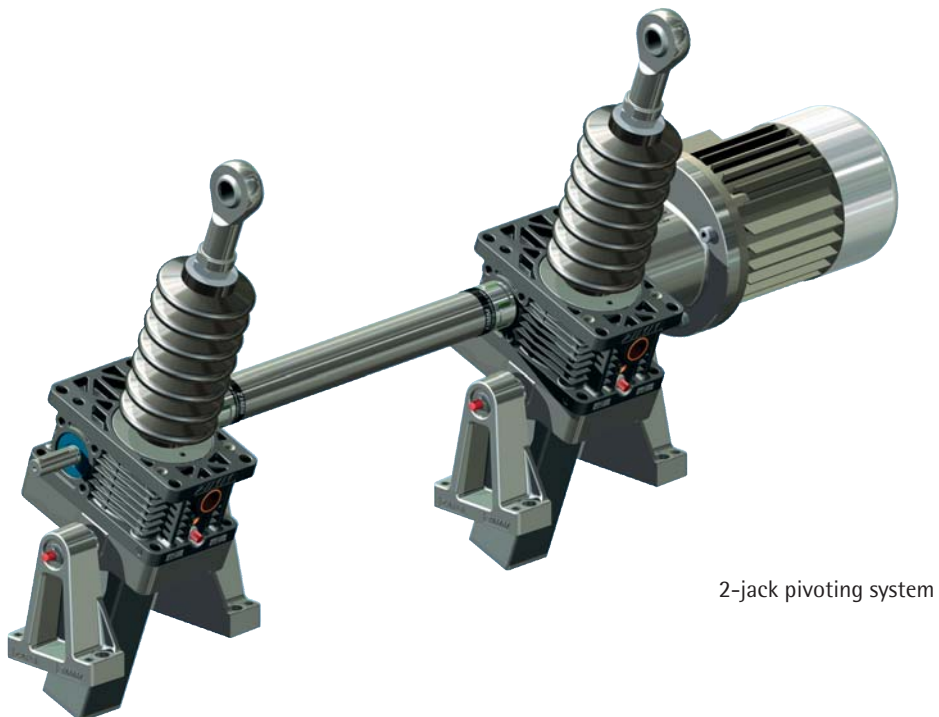
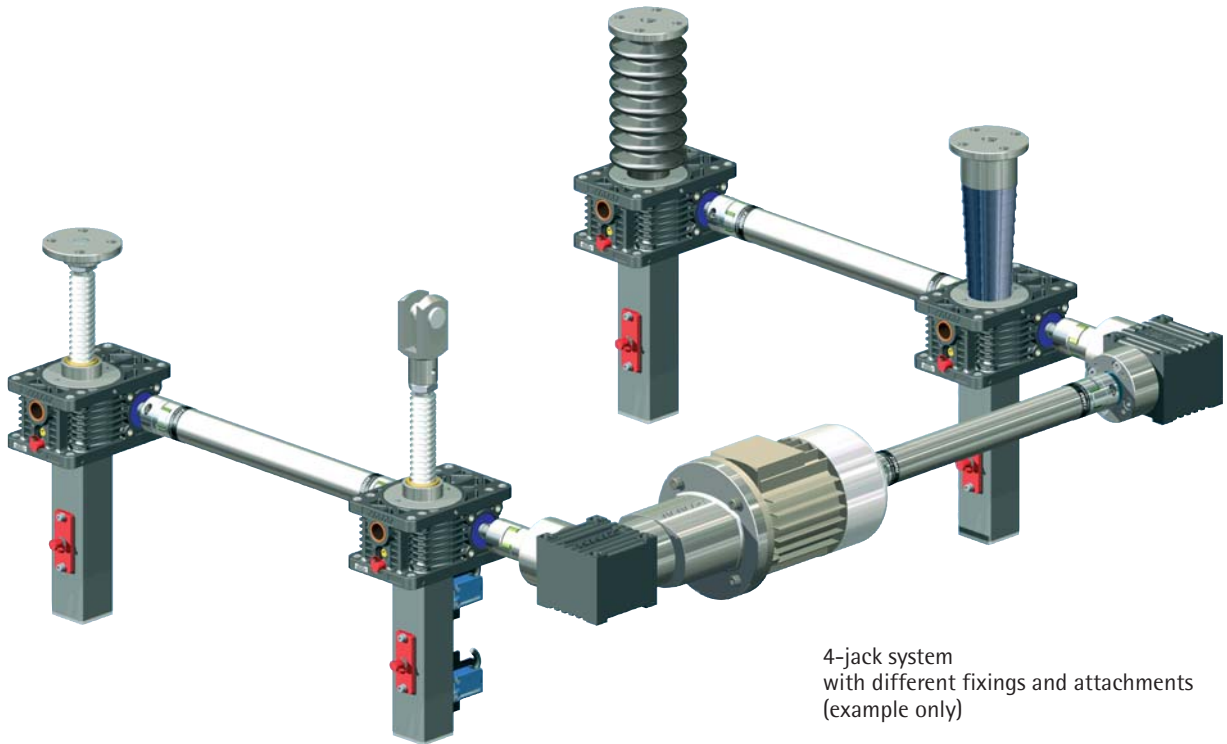

We have patents registered or pending for a range of functions and components.



Overview

Sizes/types

Z series

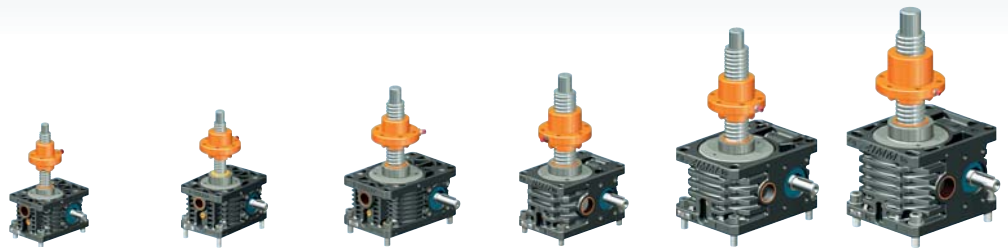
(Section 2)





Load	5 kN		10 kN		25 kN		35 kN		50 kN		100 kN	
	S	R	S	R	S	R	S	R	S	R	S	R
S translating screw R rotating screw	Version	Version	Version	Version	Version	Version	Version	Version	Version	Version	Version	Version
Drive ratios	i= 4:1 i= 16:1		i= 4:1 i= 16:1		i= 6:1 i= 24:1		i= 7:1 i= 28:1		i= 7:1 i= 28:1		i= 9:1 i= 36:1	
Housing material	Aluminium		Aluminium		Aluminium		GGG-50		GGG-50		GGG-50	
Z-Tr  with trapezoidal screw	18x4	18x4	20x4	20x4	30x6	30x6	40x7	40x7	40x7 50x8	40x7	55x9	55x9
Z-KGT  with ball screw	16x5 16x10	16x5 16x10	25x5 25x10 25x25 25x50	25x5 25x10 25x25 25x50	32x5 32x10 32x20 32x40	32x5 32x10 32x20 32x40			40x5 40x10 40x20 40x40	40x5 40x10 40x20 40x40	50x10 50x20 50x40	50x10 50x20 50x40 50x50
Z-SIFA  with safety nut		18x4	20x4	20x4	30x6	30x6	40x7	40x7	40x7	40x7	55x9	55x9

GSZ series

(Section 3)



Load	2.5 kN		5 kN		10 kN		25 kN		50 kN		100 kN			
	S	R	S	R	S	R	S	R	S	R	S	R		
S translating screw R rotating screw	Version	Version	Version	Version	Version	Version	Version	Version	Version	Version	Version	Version		
Drive ratios	i= 4:1 i= 16:1		i= 4:1 i= 16:1		i= 4:1 i= 16:1		i= 6:1 i= 24:1		i= 7:1 i= 28:1		i= 9:1 i= 36:1			
Housing material	Aluminium		Aluminium		Aluminium		Aluminium		GGG-50		GGG-50			
GSZ-Tr  with trapezoidal screw	16x4	16x4	18x4	18x4	20x4	20x4	30x6	30x6			40x7	40x7	55x9	55x9
GSZ-KGT  with ball screw		16x5 16x10	16x5 16x10	16x5 16x10	25x5 25x10 25x25 25x50	25x5 25x10 25x25 25x50	32x5 32x10 32x20 32x40	32x5 32x10 32x20 32x40			40x5 40x10 40x20 40x40	40x5 40x10 40x20 40x40	50x10 50x20 50x40 50x50	
GSZ-SIFA  with safety nut		16x4		18x4	20x4	20x4	30x6	30x6			40x7	40x7	55x9	55x9

Screw versions: increased / double-pitch / left-handed / stainless steel

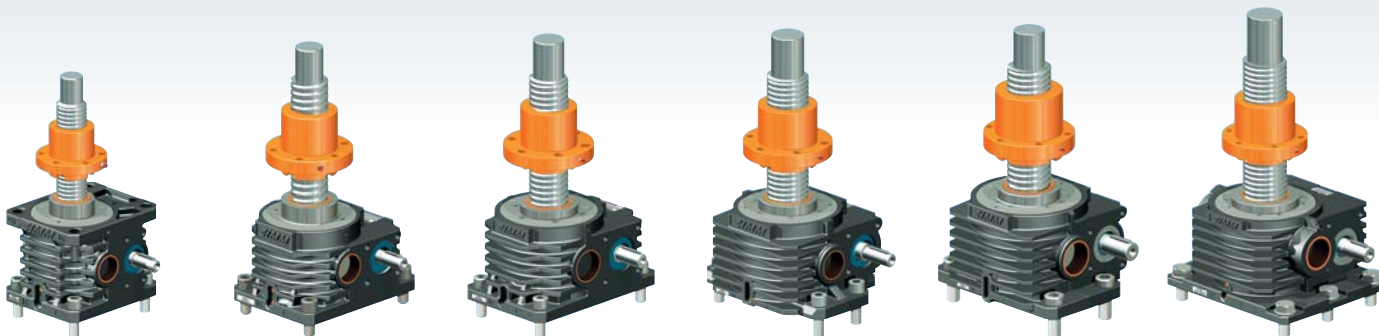

150 kN		250 kN		350 kN		500 kN		750 kN		1000 kN	
S	R	S	R	S	R	S	R	S	R	S	R
Version	Version	Version	Version	Version	Version	Version	Version	Version	Version	Version	Version
i= 9:1		i= 10.66:1		i= 10.66:1		i= 10.66:1		i= 13.33:1		i= 13.33:1	
i= 36:1		i= 32:1		i= 32:1		i= 32:1		i= 40:1		i= 40:1	
GGG-50		GGG-50		GGG-50		GGG-50		GGG-50		GGG-50	
60x9	60x9	80x16	80x16	100x16	100x16	120x16	120x16	140x20	140x20	160x20	160x20
63x10 63x20 63x40 63x60	63x10 63x20 63x40 63x60	80x10 80x20 80x40 80x60	80x10 80x20 80x40 80x60	100x20 100x40 100x60 100x80	100x20 100x40 100x60 100x80	125x25 125x40 125x60 125x80	125x25 125x40 125x60 125x80	140x25 140x40 140x60 140x80	140x25 140x40 140x60 140x80	160x25 160x40 160x60 160x80	160x25 160x40 160x60 160x80
60x9	60x9	80x16	80x16	100x16	100x16	120x16	120x16	140x20	140x20	160x20	160x20

When should I use a Z series screw jack?

Z series screw jacks are the preferred range with the largest number of types. The Z series feature through holes for top mounting and integral pivot bearings, features not available on the GSZ series.

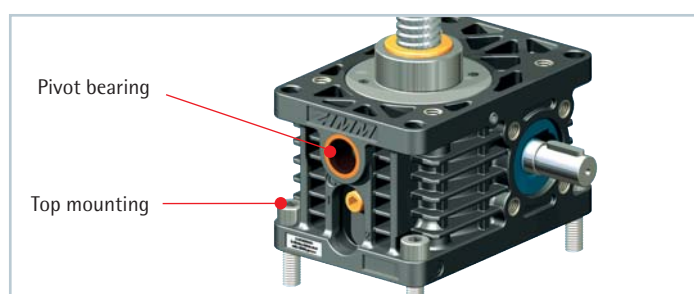

When should I use a GSZ series screw jack?

GSZ series screw jacks are designed for applications where smooth surfaces are required. These screw jacks are easier to clean and therefore ideal for applications in the food processing industry.

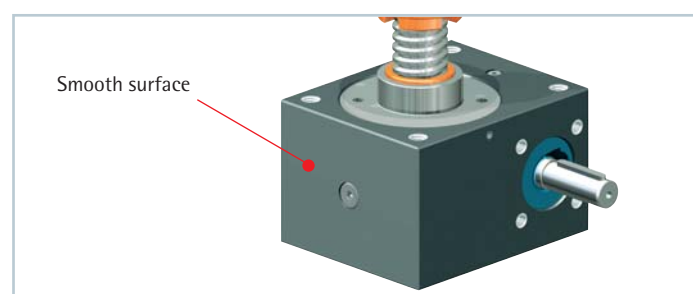

The development of ZIMM screw jack system

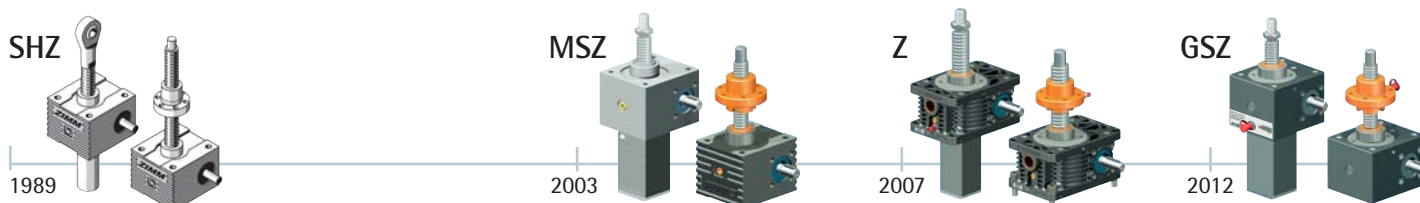

NOTE:

SHZ and MSZ series units made from cast iron and aluminium are available as spare parts on request. We will be happy to offer advice on conversion to the new Z and GSZ types.

S version (Translating screw)

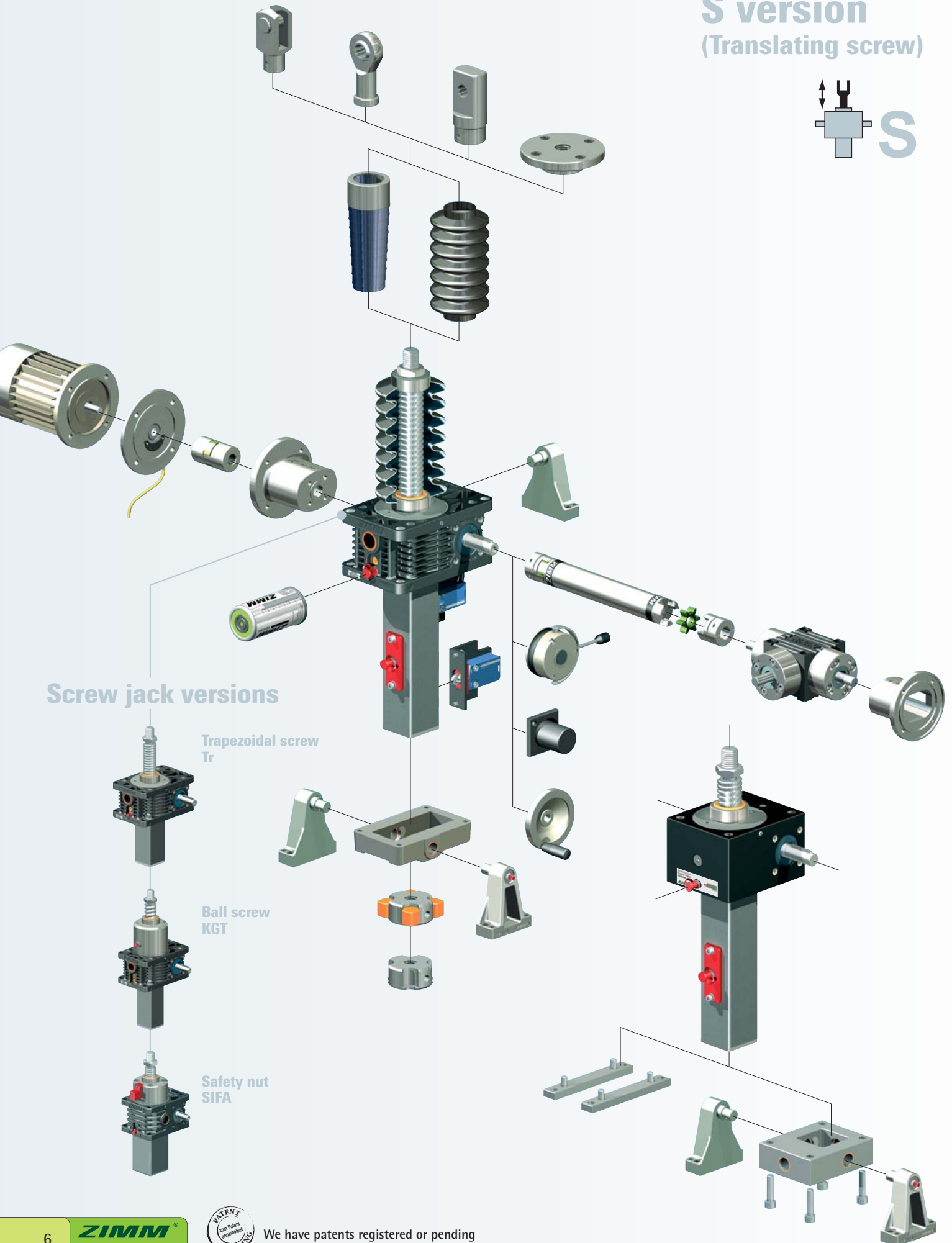
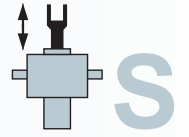

Screw jack versions

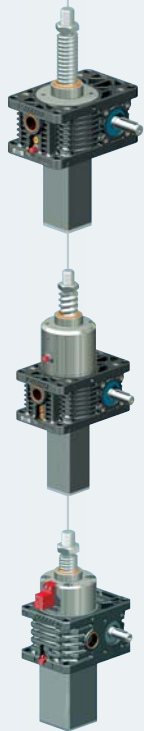

Trapezoidal screw
Tr

Ball screw
KGT

Safety nut
SIFA



R version (Rotating screw)

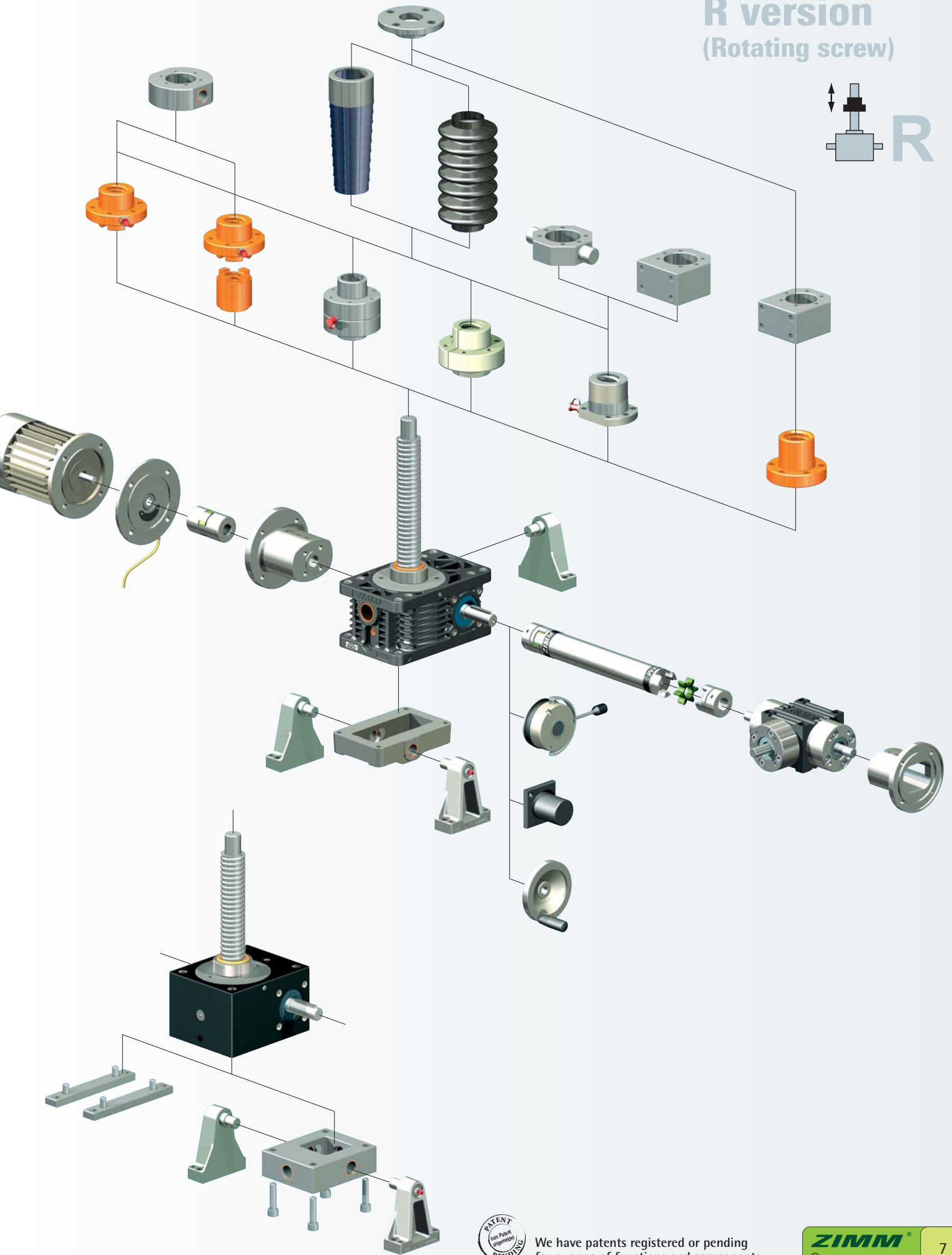
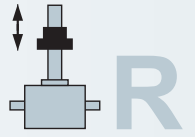

We have patents registered or pending for a range of functions and components.

Z series - features

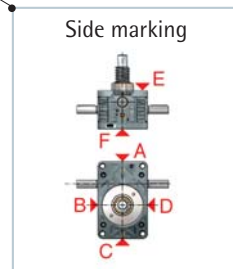
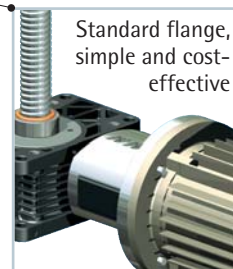
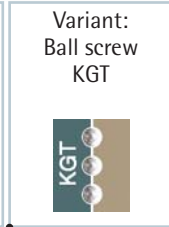
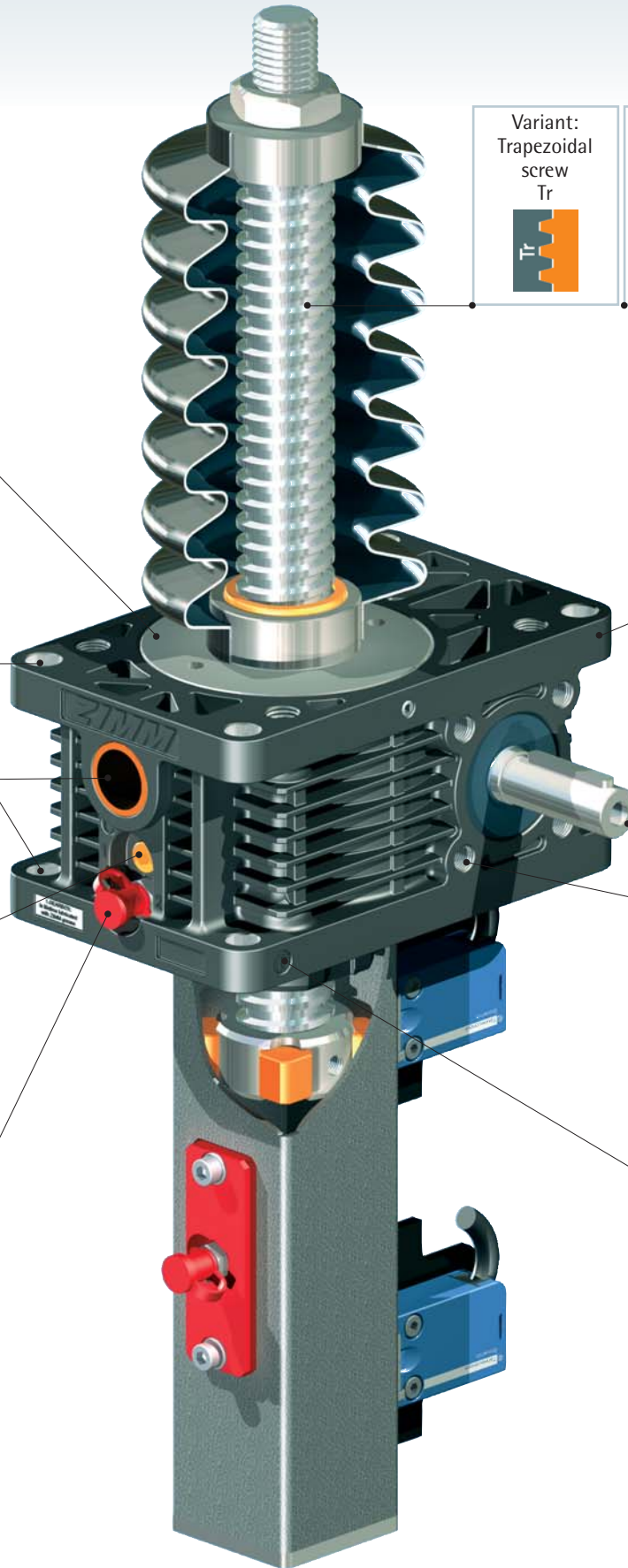
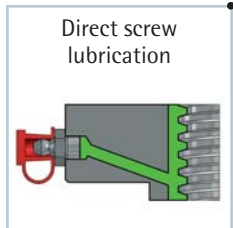
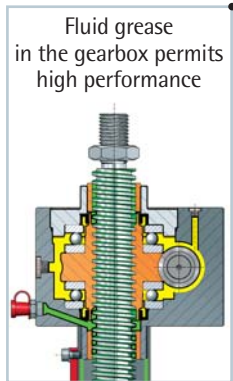
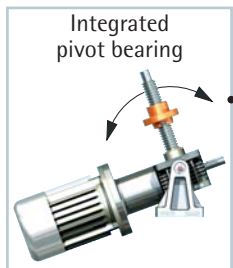
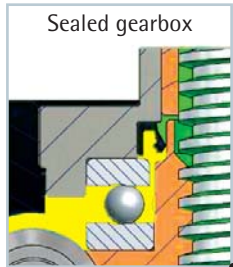

GSZ series - features

Optional stainless steel screw

Sealed gearbox

Top or bottom mounting

Fluid grease in the gearbox permits high performance

Direct screw lubrication

Variant: Trapezoidal screw Tr

Variant: Safety nut SIFA

Variant: Ball screw KGT

Corrosion resistant

Smooth, easy-to-clean surface

High-performance hardened and ground gears

Standard flange, simple and cost-effective



We have patents registered or pending for a range of functions and components.



Peo

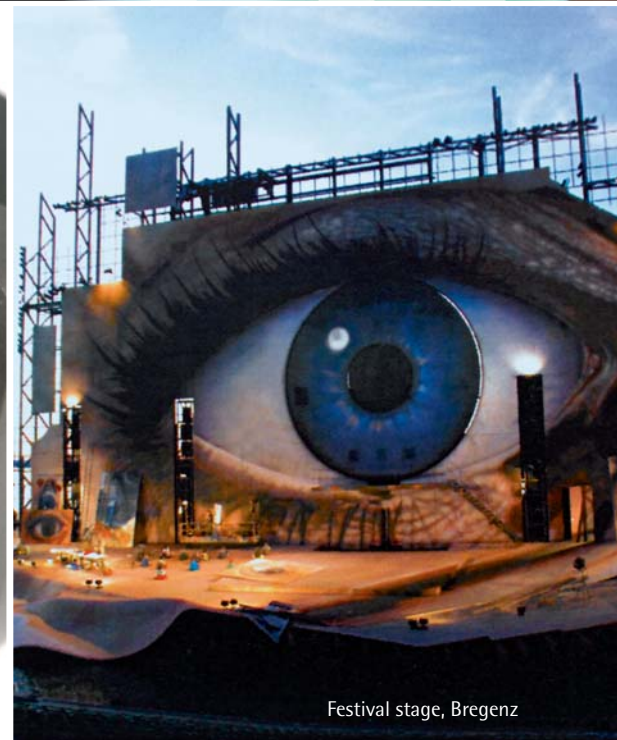

Festival stage, Bregenz

product and environment...



ple...



Bodensee, Hard

in harmony!

Z series

Z series screw jacks are the preferred range with the largest number of types. The Z series features through holes for top mounting and integral pivot bearings, features not available on the GSZ series.

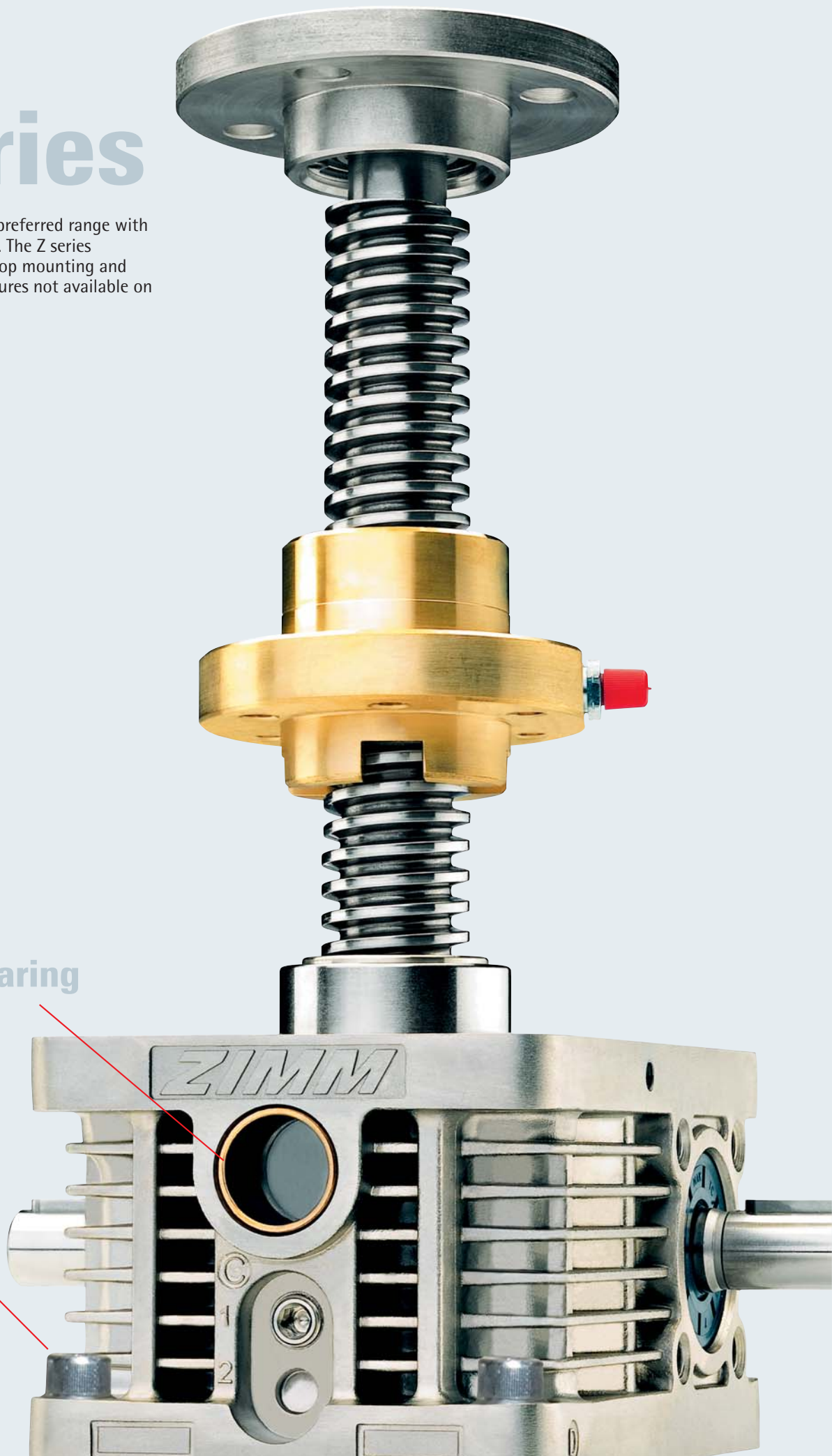

Pivot bearing

Top mounting

Types and sizes

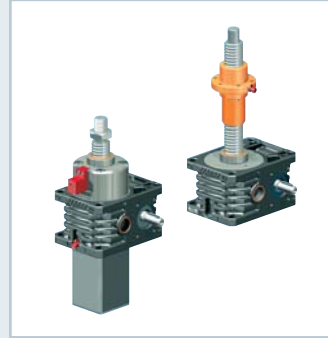
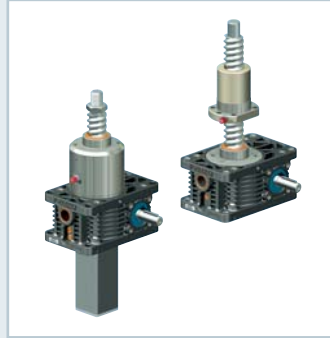
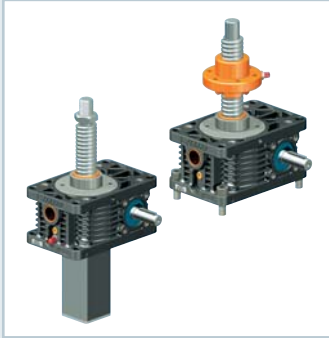

Z series jacks Tr
Trapezoidal screw
5 kN to 1,000 kN

Pages 14 - 39



Z series jacks KGT
Ball screw
5 kN to 1,000 kN

Pages 40 - 49



Z series jacks SIFA
Safety nut
5 kN to 1,000 kN

Pages 50 - 55



We have patents registered or pending for a range of functions and components.

Trapezoidal screw

Tr



Z-5-R rotating screw 5 kN

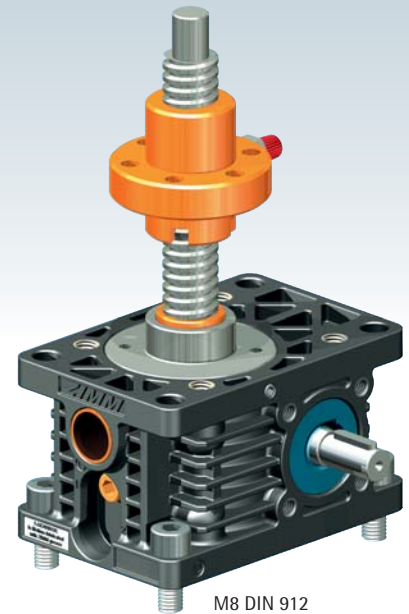
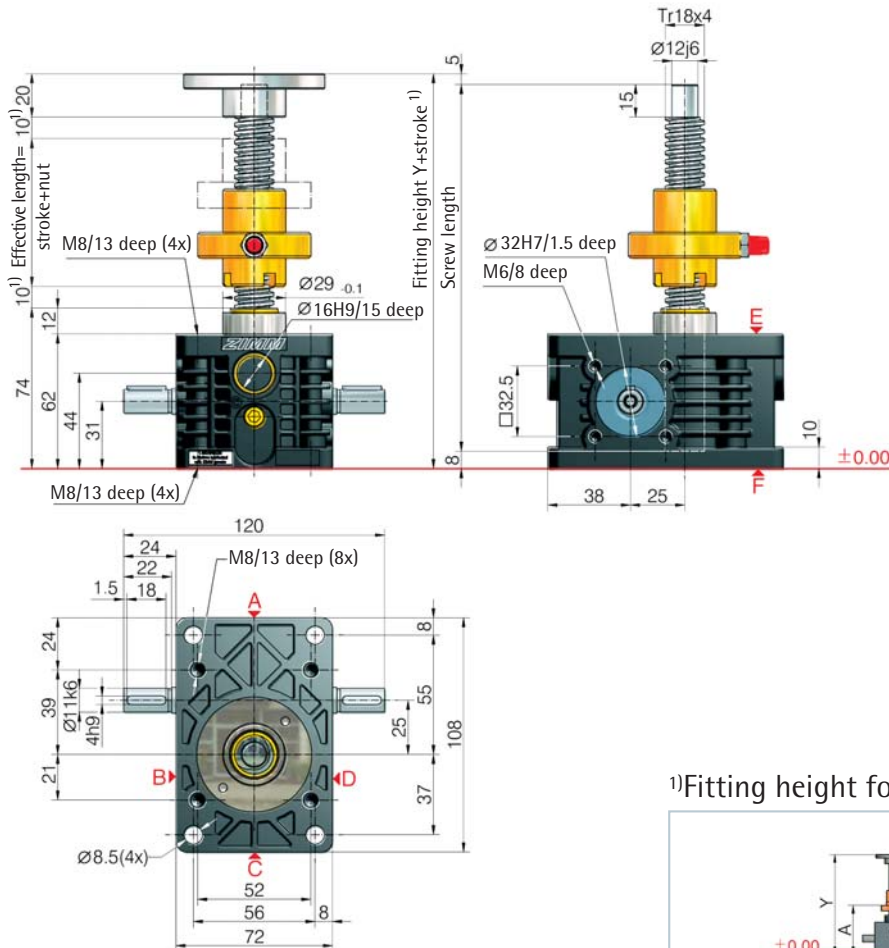

M8 DIN 912

5 kN

1) Fitting height for 0-stroke, with Tr 18x4 screw

All dimensions in mm	Flange nut FM	Duplex nut DM	Duplex nut DM with SIFA	Self-aligning nut PM	Greaseless nut FFDM
	Y/A	Y/A	Y/A	Y/A	Y/A
Bellows FB	149/96	159/109	184/134	192/141	167/117
without bellows FB	-	207/132	229/154	240/164	215/140
2x Z-5-FB-265	-	337/197	359/219	370/229	345/205
2x Z-5-FB-500	-	377/217	399/239	410/249	385/225

Detailed instructions for determining the length can be found in Section 8

Technical data series Z-5-S / Z-5-R

max. compressive/tensile force, static	- 5 kN (0.5 t)
max. compressive/tensile force, dynamic	- see duty cycle curves
Nominal speed	- 1500 rpm
max. drive shaft speed	- 3000 rpm (depending on the load and duty cycle)
Screw size standard	- Tr 18x4 ²⁾
Gear ratio	- 4:1 (N) / 16:1 (L)
Housing material	- aluminium, corrosion-resistant
Worm shaft	- steel, case-hardened, ground
Weight of screw jack body	- 1.2 kg
Weight of screw/m	- 1.58 kg
Gearbox lubrication	- synthetic fluid grease
Screw lubrication	- grease lubrication
Gearbox operating temperature	- max. 60°C, higher on request
Moment of inertia	- N: 0.217 kg cm ² / L: 0.117 kg cm ²
Input torque (at 1500 rpm)	- max. 4.7 Nm (N) / max. 1.5 Nm (L)
Drive-through torque	- max. 39 Nm

Drive torque M_G (Nm)	- F (kN) \times 0.62 ³⁾⁵⁾ + M_L (N-normal)
Breakaway torque	- F (kN) \times 0.21 ³⁾⁵⁾ + M_L (L-low)
Idling torque ⁴⁾ M_L (Nm)	- Drive torque M_G \times 1.5
	- 0.10 (N-normal) / 0.08 (L-low speed)

Between gearbox and nut or nut and end of thread, provide for a safety distance of (minimum) 10 mm!

See Section 7 for the checklist.

Important information

- 1) - extension if a bellows or spiral spring is fitted: see the table or Section 8
- 2) - Tr 18x4 is standard, also available: double-pitch, stainless steel, left-handed, increased screw Tr 20x4 (only for the R version)
- 3) - factor includes efficiency, ratio and 30% safety
- 4) - at 20°C, can be higher when new
- 5) - for a 4 mm screw pitch



Z-10-S translating screw 10 kN

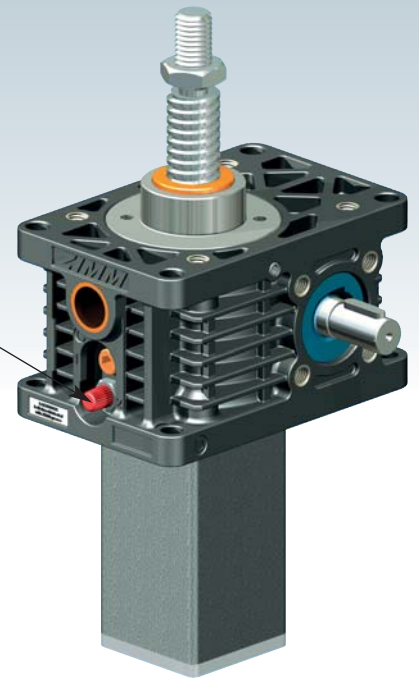

UNIQUE:
Screw lubrication
during operation

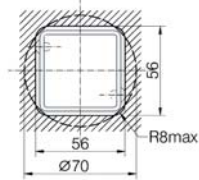
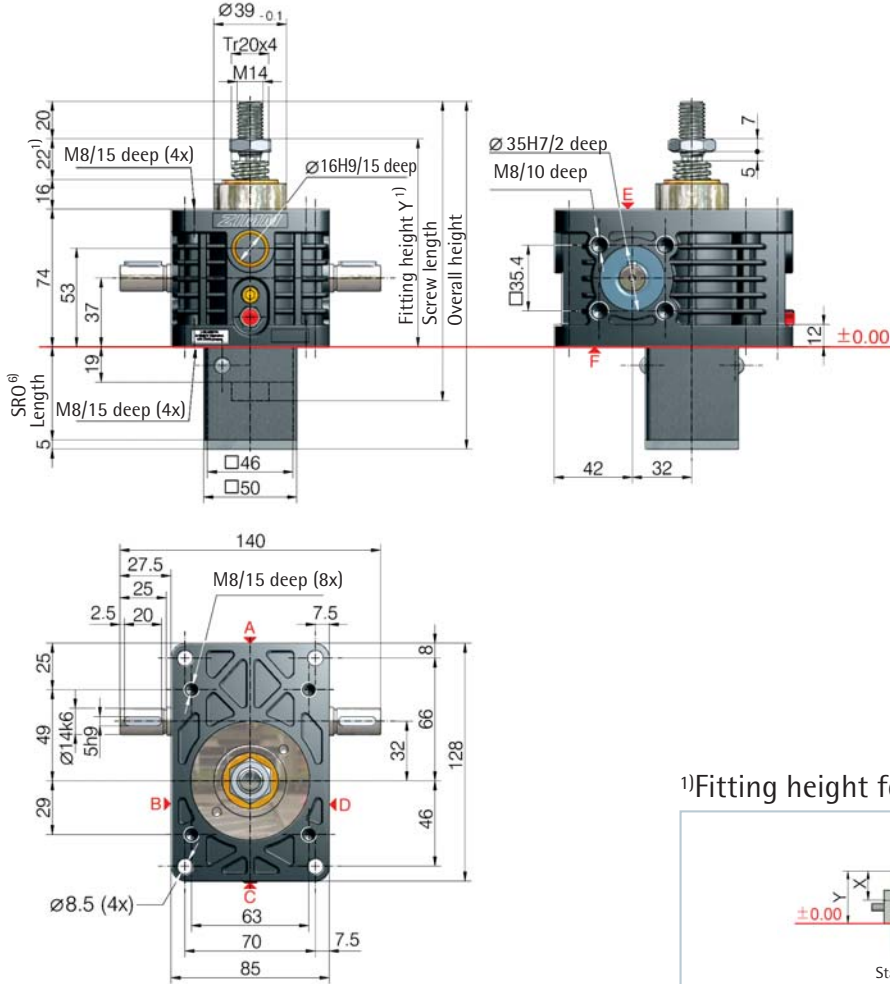

6) Protective tube length SRO with Tr 20x4 screw

Without escape/ rotation protection	Escape/ rotation protection	Rotation protection, with limit switch set ES	Rotation protection with ES and KAR*
49+stroke	69+stroke	121+stroke	141+stroke

*Hinged bearing plate KAR, fitted on face F (below).

1) Fitting height for 0-stroke, with Tr 20x4 screw

All dimensions in mm

Bellocs FB	X/Y	X/Y	X/Y	X/Y	X/Y
without bellocs FB	59/112	80/133	115/168	120/173	115/168
Z-10-FB-340	140/193	136/189	196/249	201/254	171/224
Z-10-FB-700	160/213	156/209	216/269	221/274	191/244
Z-10-FB-1000	210/263	206/259	266/319	271/324	241/294

Standard screw end*, Fixing flange BF, Forked end GK*, Rod end K GK*, Pivot bearing end SLK

*with bellows fixing ring Z-10-FBR

Standard ratios

Type	Version	Speed	Standard screw ²⁾	i	Stroke per drive shaft rotation ⁵⁾
Z-10-SN	Translating	Normal	Tr 20x4	4:1	1.00 mm
Z-10-SL	screw	Low speed		16:1	0.25 mm
Z-10-RN	Rotating	Normal	Tr 20x4	4:1	1.00 mm
Z-10-RL	screw	Low speed		16:1	0.25 mm

Screw jack mounting



Duty cycle thermal limit, for S+R

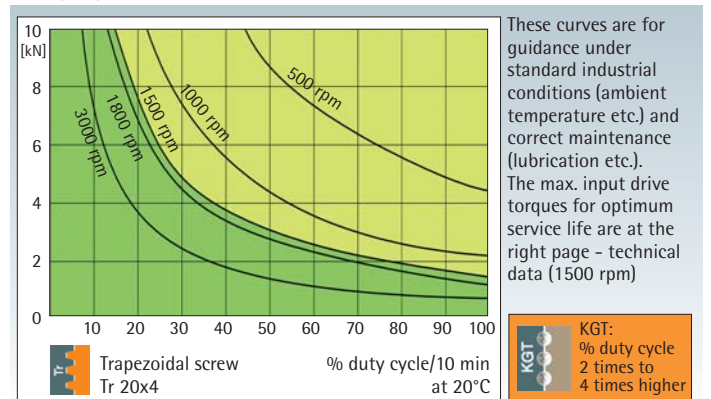



Z-25-S translating screw 25 kN

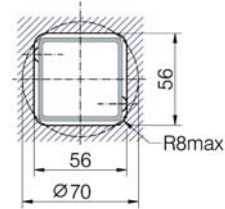
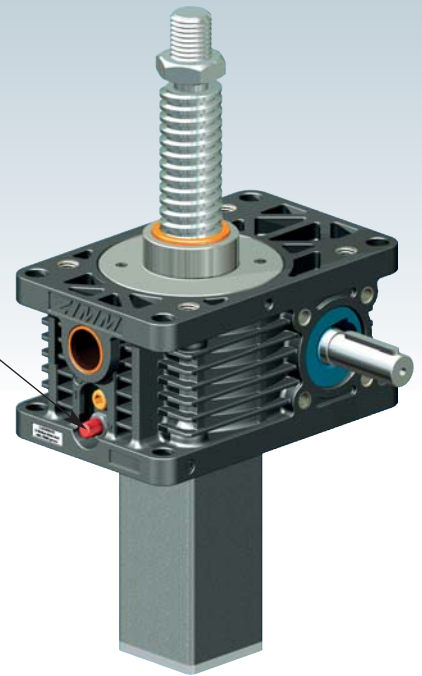
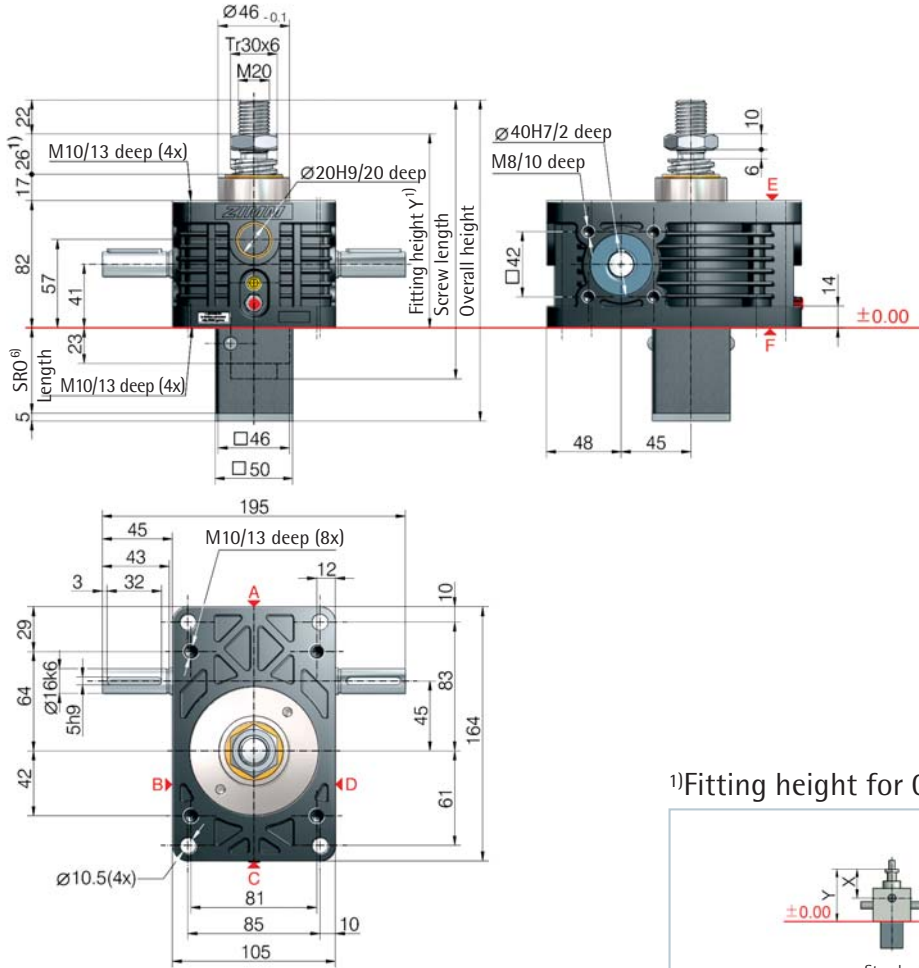

Opening for protective tube SRO square 56x56 or round Ø 70

6) Protective tube length SRO with Tr 30x6 screw

Without escape/ rotation protection	Escape/ rotation protection	Rotation protection, with limit switch set ES	Rotation protection with ES and KAR*
53+stroke	73+stroke	125+stroke	149+stroke

*Hinged bearing plate KAR, fitted on face F (below).

1) Fitting height for 0-stroke, with Tr 30x6 screw

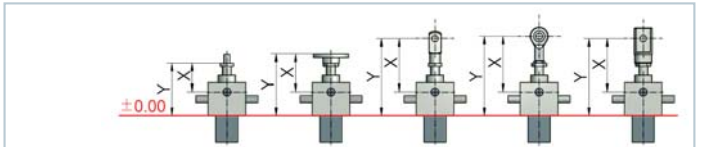

All dimensions in mm

Bellocs FB	X/Y	X/Y	X/Y	X/Y	X/Y
without bellocs FB	68/125	91/148	148/205	145/202	148/205
Z-25-FB-300	143/200	135/192	223/280	220/277	192/249
Z-25-FB-700	173/230	165/222	253/310	250/307	222/279
Z-25-FB-1000	193/250	185/242	273/330	270/327	242/299

*with bellows fixing ring Z-25-FBR

Standard ratios

Type	Version	Speed	Standard screw ²⁾	i	Stroke per drive shaft rotation ⁵⁾
Z-25-SN	Translating	Normal	Tr 30x6	6:1	1.00 mm
Z-25-SL	screw	Low speed		24:1	0.25 mm
Z-25-RN	Rotating	Normal	Tr 30x6	6:1	1.00 mm
Z-25-RL	screw	Low speed		24:1	0.25 mm

Screw jack mounting



Duty cycle thermal limit, for S+R

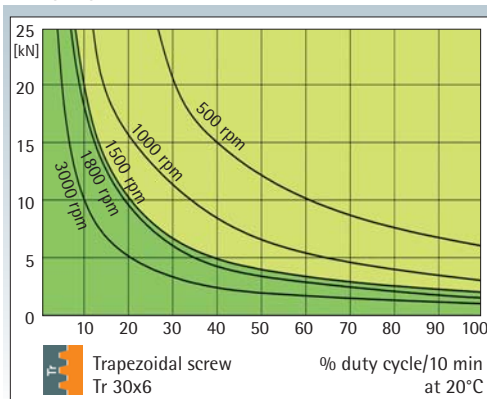

These curves are for guidance under standard industrial conditions (ambient temperature etc.) and correct maintenance (lubrication etc.). The max. input drive torques for optimum service life are at the right page - technical data (1500 rpm)

KGT: % duty cycle 2 times to 4 times higher

Trapezoidal screw

Tr



Z-25-R rotating screw 25 kN

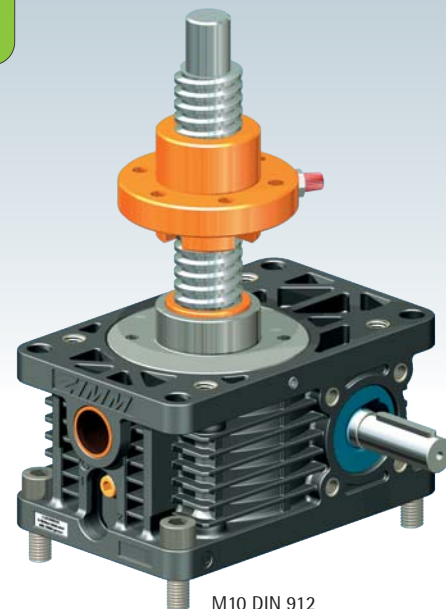
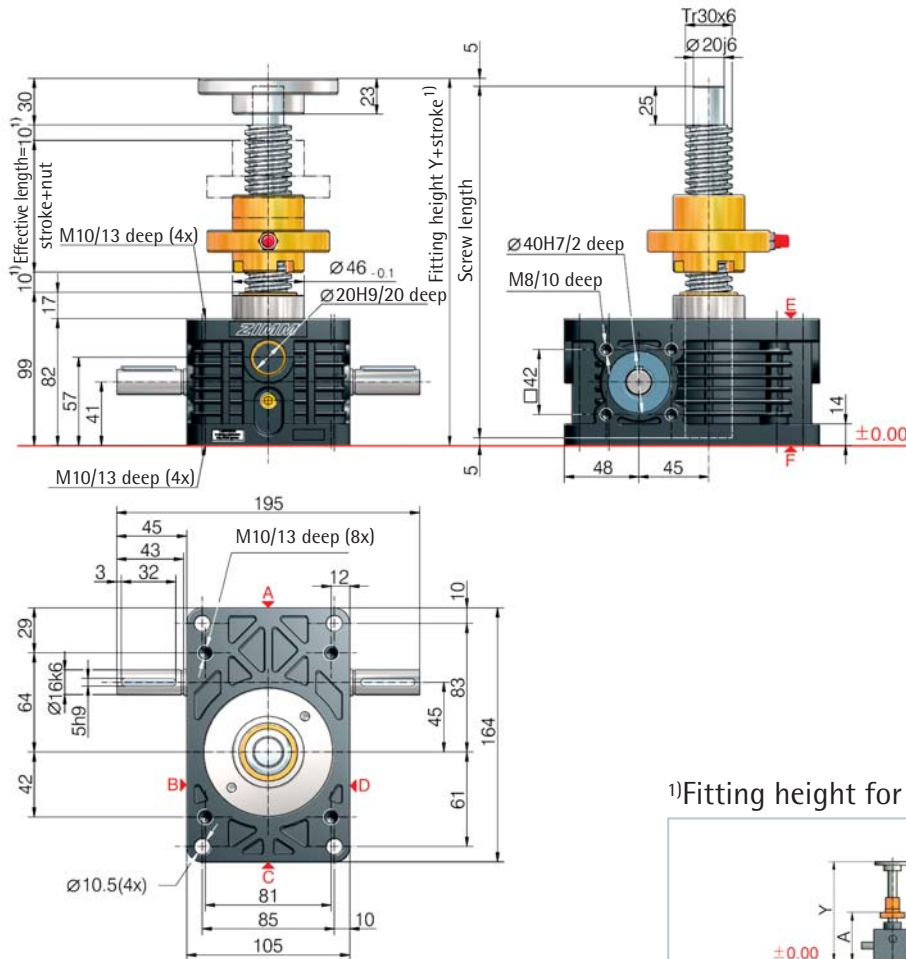

M10 DIN 912

2

25

kN

¹⁾Fitting height for 0-stroke, with Tr 30x6 screw

All dimensions in mm	Flange nut FM	Duplex nut DM	Duplex nut DM with SIFA	Self-aligning nut PM	Greaseless nut FFDM
Bellows FB	Y/A	Y/A	Y/A	Y/A	Y/A
without bellows FB	195/123	199/136	244/181	244/177	208/145
2x Z-25-FB-300	-	314/196	353/235	359/237	325/207
2x Z-25-FB-700	-	374/226	413/265	419/267	385/237
2x Z-25-FB-1000	-	414/246	453/285	459/287	425/257

Detailed instructions for determining the length can be found in Section 8

Technical data series Z-25-S / Z-25-R

max. compressive/tensile force, static	- 25 kN (2.5 t)
max. compressive/tensile force, dynamic	- see duty cycle curves
Nominal speed	- 1500 rpm
max. drive shaft speed	- 3000 rpm (depending on the load and duty cycle)
Screw size standard	- Tr 30x6 ²⁾
Gear ratio	- 6:1 (N) / 24:1 (L)
Housing material	- aluminium, corrosion-resistant
Worm shaft	- steel, case-hardened, ground
Weight of screw jack body	- 3.8 kg
Weight of screw/m	- 4.5 kg
Gearbox lubrication	- synthetic fluid grease
Screw lubrication	- grease lubrication
Gearbox operating temperature	- max. 60°C, higher on request
Moment of inertia	- N: 1.449 kg cm ² / L: 0.589 kg cm ²
Input torque (at 1500 rpm)	- max. 18 Nm (N) / max. 10 Nm (L)
Drive-through torque	- max. 108 Nm

Drive torque M_G (Nm)	- F (kN) \times 0.63 ³⁾ + M_L (N-normal)
Breakaway torque	- F (kN) \times 0.20 ³⁾ + M_L (L-low speed)
Idling torque ⁴⁾ M_L (Nm)	- Drive torque M_G \times 1.5
	- 0.36 (N-normal) / 0.26 (L-low speed)

Between gearbox and nut or nut and end of thread, provide for a safety distance of (minimum) 10 mm!

See Section 7 for the checklist.

Important information

- 1) - extension if a bellows or spiral spring is fitted: see the table or Section 8
- 2) - Tr 30x6 is standard, also available: double-pitch, stainless steel, left-handed, increased screw Tr 40x7 (only for the R version)
- 3) - factor includes efficiency, ratio and 30% safety
- 4) - at 20°C, can be higher when new
- 5) - for a 6 mm screw pitch



UNIQUE:
Screw lubrication
during operation

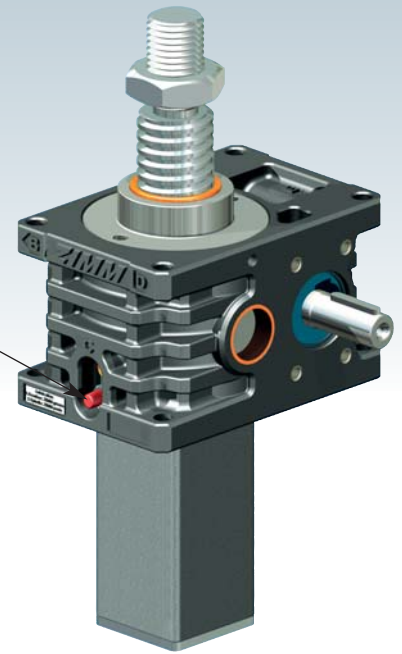

Z-35-S translating screw 35 kN

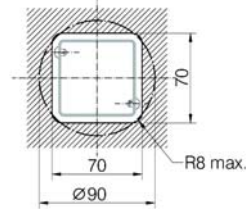
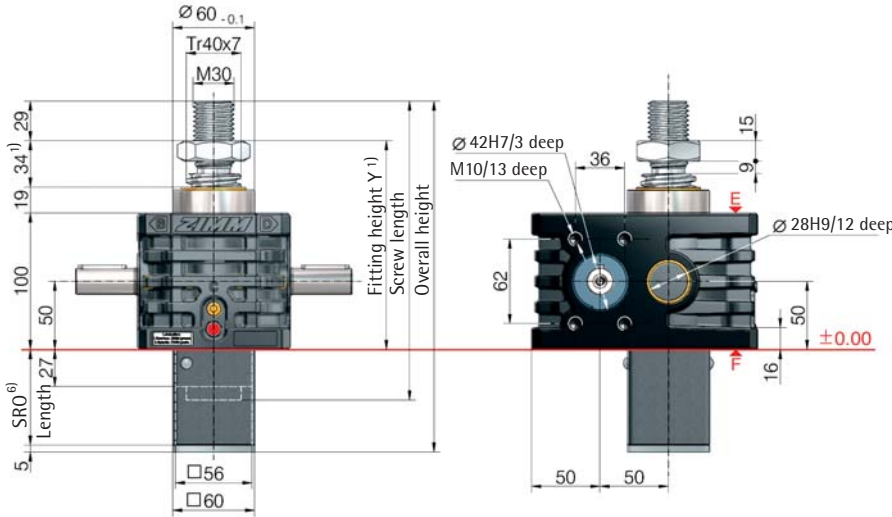

Opening for
protective tube SRO
square 70x70
or round Ø 90

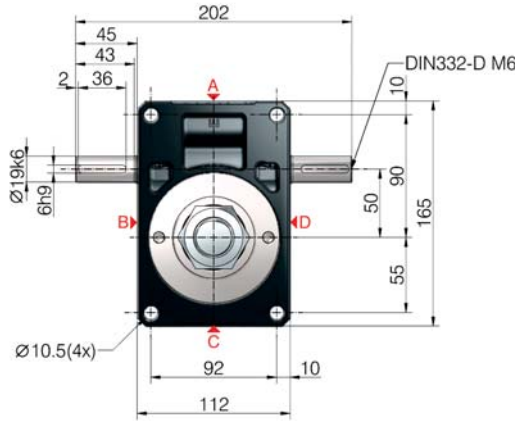

1) Fitting height for 0-stroke, with Tr 40x7 screw

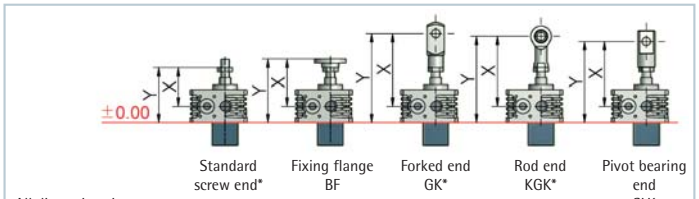

All dimensions in mm

Bellocs FB	X/Y	X/Y	X/Y	X/Y	X/Y
without bellocs FB	103/153	133/183	223/273	213/263	195/245
Z-50-FB-390	198/248	182/232	318/368	308/358	244/294
Z-50-FB-600	185/235	169/219	305/355	295/345	231/281
Z-50-FB-1000	243/293	227/277	363/413	353/403	289/339
Z-50-FB-1200	238/288	222/272	358/408	348/398	284/334
Z-50-FB-1500	293/343	277/327	413/463	403/453	339/389

*with bellocs fixing ring Z-50-FBR

6) Protective tube length SRO with Tr 40x7 screw

Without escape/ rotation protection	Escape/ rotation protection	Rotation protection, with limit switch set ES
57+stroke	87+stroke	143+stroke

Standard ratios

Type	Version	Speed	Standard screw ²⁾	i	Stroke per drive shaft rotation ⁵⁾
Z-35-SN	Translating	Normal	Tr 40x7	7:1	1.00 mm
Z-35-SL	screw	Low speed		28:1	0.25 mm
Z-35-RN	Rotating	Normal	Tr 40x7	7:1	1.00 mm
Z-35-RL	screw	Low speed		28:1	0.25 mm

Screw jack mounting



Duty cycle thermal limit, for S+R

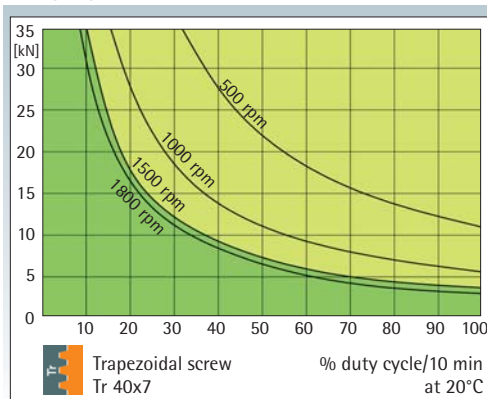

These curves are for guidance under standard industrial conditions (ambient temperature etc.) and correct maintenance (lubrication etc.). The max. input drive torques for optimum service life are at the right page - technical data (1500 rpm)

KGK:
% duty cycle
2 times to
4 times higher

Trapezoidal screw

Tr



Z-35-R rotating screw 35 kN

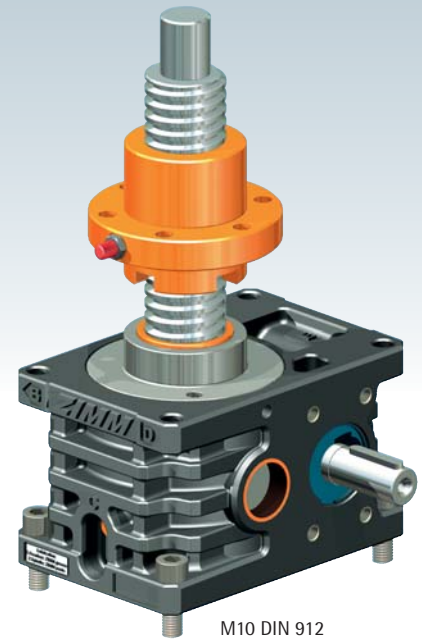
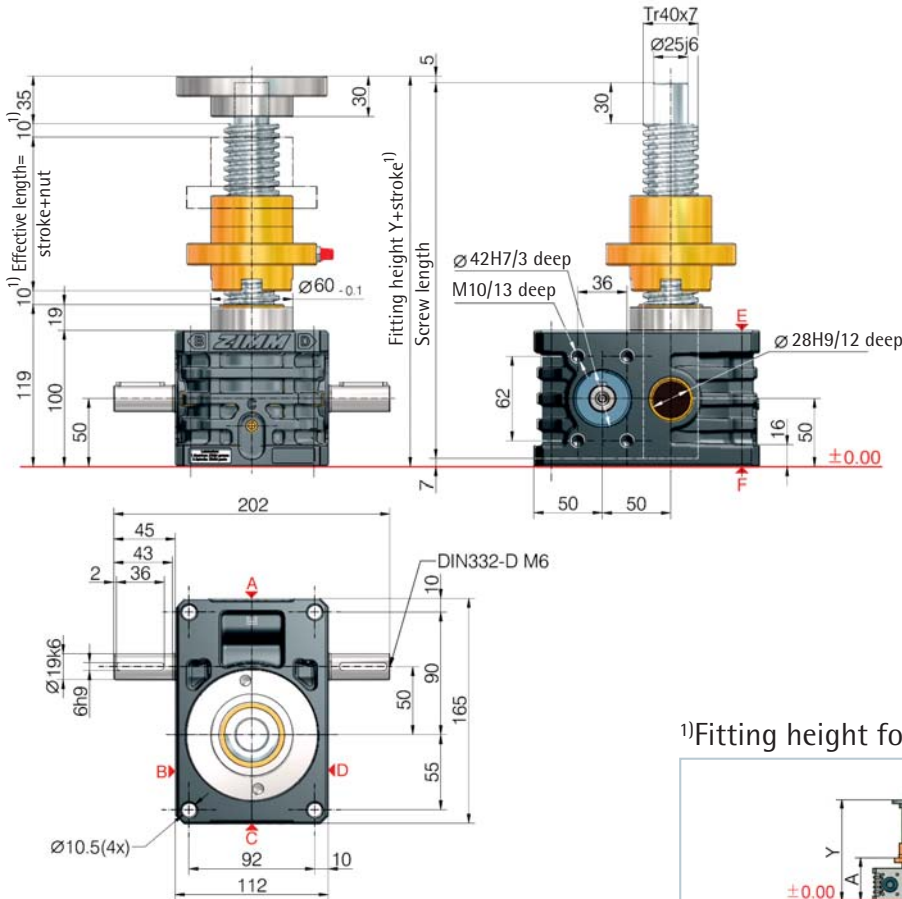

M10 DIN 912

1) Fitting height for 0-stroke, with Tr 40x7 screw

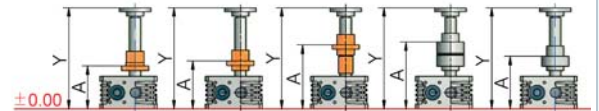

All dimensions in mm	Flange nut FM	Duplex nut DM	Duplex nut DM with SIFA	Self-aligning nut PM	Greaseless nut FFDM
Bellows FB	Y/A	Y/A	Y/A	Y/A	Y/A
without bellows FB	240/145	244/163	307/226	303/228	259/179
2x Z-50-FB-390	-	387/236	446/295	446/301	404/254
2x Z-50-FB-600	-	361/223	420/282	420/288	378/241
2x Z-50-FB-1000	-	477/281	536/340	536/346	494/299
2x Z-50-FB-1200	-	467/276	526/335	526/341	484/294
2x Z-50-FB-1500	-	577/331	636/390	636/396	594/349

Detailed instructions for determining the length can be found in Section 8

35

kN

Technical data series Z-35-S / Z-35-R

max. compressive/tensile force, static	- 35 kN (3.5 t)
max. compressive/tensile force, dynamic	- see duty cycle curves
Nominal speed	- 1500 rpm
max. drive shaft speed	- 1800 rpm
Screw size standard	- Tr 40x7 ²⁾
Gear ratio	- 7:1 (N) / 28:1 (L)
Housing material	- GGG-50, corrosion-resistant
Worm shaft	- steel, case-hardened, ground
Weight of screw jack body	- 9.5 kg
Weight of screw/m	- 8 kg
Gearbox lubrication	- synthetic fluid grease
Screw lubrication	- grease lubrication
Gearbox operating temperature	- max. 60°C, higher on request
Moment of inertia	- N: 2.18 kg cm ² / L: 0.90 kg cm ²
Input torque (at 1500 rpm)	- max. 19.8 Nm (N) / max. 9 Nm (L)
Drive-through torque	- max. 130 Nm

Drive torque M_0 (Nm)	- F (kN) \times 0.69 ³⁾⁵⁾ + M_L (N-normal)
Breakaway torque	- F (kN) \times 0.23 ³⁾⁵⁾ + M_L (L-low speed)
Idling torque ⁴⁾ M_L (Nm)	- Drive torque M_0 \times 1.5
	- 0.56 (N-normal) / 0.40 (L-low speed)

Between gearbox and nut or nut and end of thread, provide for a safety distance of (minimum) 10 mm!

See Section 7 for the checklist.

Important information

- 1) - extension if a bellows or spiral spring is fitted: see the table or Section 8
- 2) - Tr 40x7 is standard, also available: double-pitch, stainless steel, left-handed, increased screw Tr 55x9 (only for the R version)
- 3) - factor includes efficiency, ratio and 30% safety
- 4) - at 20°C, can be higher when new
- 5) - for a 7 mm screw pitch



Z-50-S translating screw 50 kN

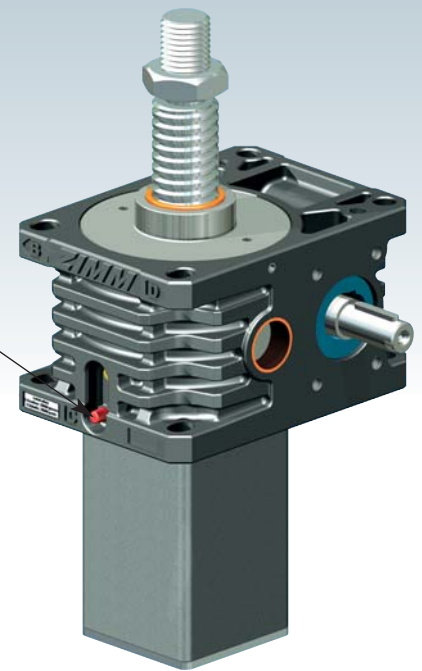

UNIQUE:
Screw lubrication
during operation

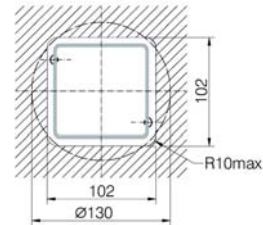
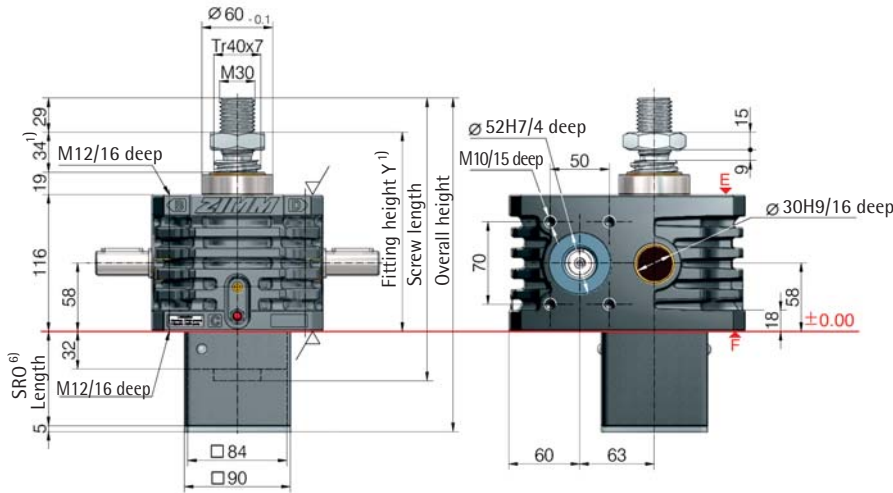

Opening for
protective tube SRO
square 102x102
or round Ø 130

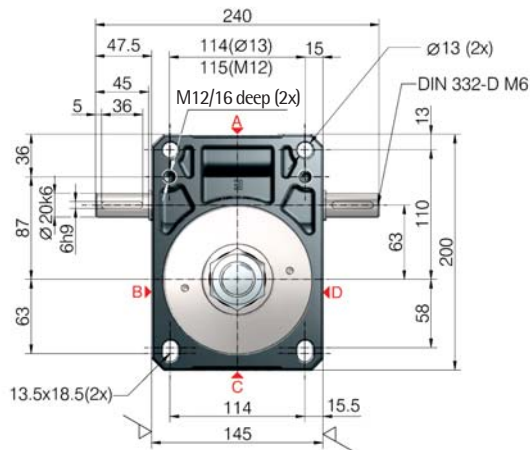

¹⁾Fitting height for 0-stroke, with Tr 40x7 screw

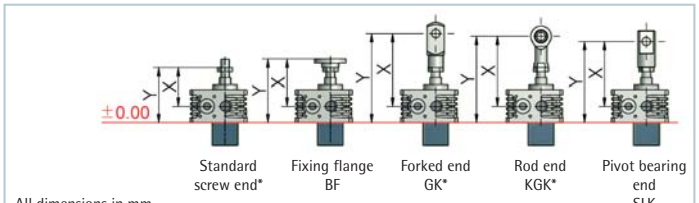

All dimensions in mm

Bellocs FB	X/Y	X/Y	X/Y	X/Y	X/Y
without bellocs FB	111/169	141/199	231/289	221/279	203/261
Z-50-FB-390	206/264	190/248	326/384	316/374	252/310
Z-50-FB-600	193/251	177/235	313/371	303/361	239/297
Z-50-FB-1000	251/309	235/293	371/429	361/419	297/355
Z-50-FB-1200	246/304	230/288	366/424	356/414	292/350
Z-50-FB-1500	301/359	285/343	421/479	411/469	347/405

*with bellocs fixing ring Z-50-FBR

⁶⁾Protective tube length SRO with Tr 40x7 screw

Without escape/rotation protection	Escape/rotation protection	Rotation protection, with limit switch set ES
62+stroke	92+stroke	144+stroke

Standard ratios

Type	Version	Speed	Standard screw ²⁾	i	Stroke per drive shaft rotation ⁵⁾
Z-50-SN	Translating	Normal	Tr 40x7	7:1	1.00 mm
Z-50-SL	screw	Low speed		28:1	0.25 mm
Z-50-RN	Rotating	Normal	Tr 40x7	7:1	1.00 mm
Z-50-RL	screw	Low speed		28:1	0.25 mm

Screw jack mounting



Duty cycle thermal limit, for S+R

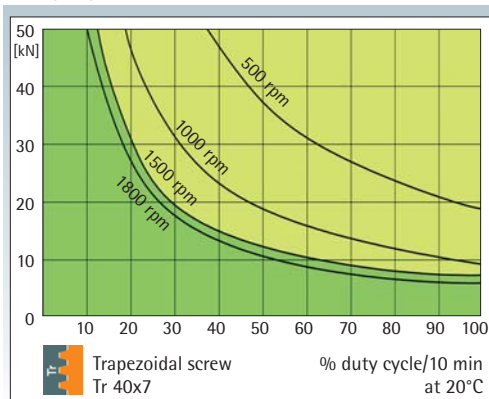

These curves are for guidance under standard industrial conditions (ambient temperature etc.) and correct maintenance (lubrication etc.). The max. input drive torques for optimum service life are at the right page - technical data (1500 rpm)

KGK:
% duty cycle
2 times to
4 times higher

Trapezoidal screw

Tr



Z-50-R rotating screw 50 kN

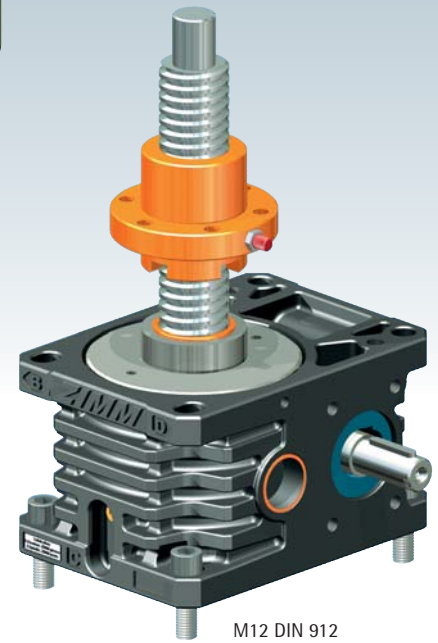
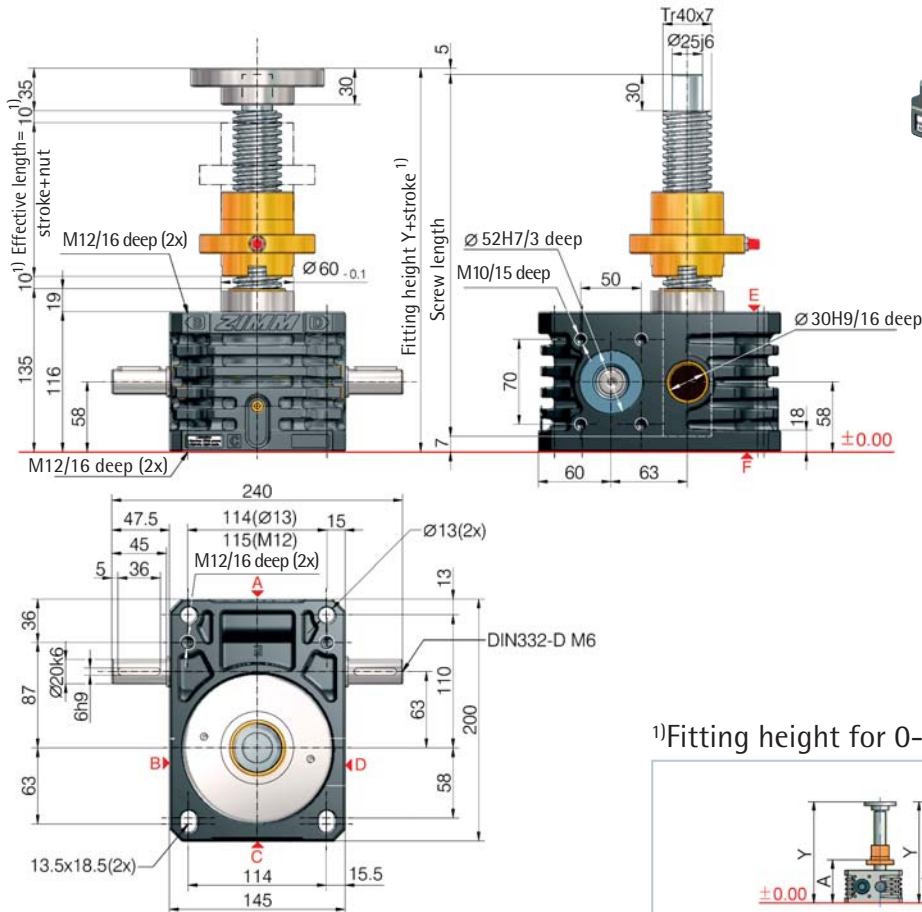

M12 DIN 912

2

1) Fitting height for 0-stroke, with Tr 40x7 screw

All dimensions in mm	Flange nut FM	Duplex nut DM	Duplex nut DM with SIFA	Self-aligning nut PM	Greasess nut FFDM
Bellows FB	Y/A	Y/A	Y/A	Y/A	Y/A
without bellows FB	256/161	260/179	323/242	319/244	275/195
2x Z-50-FB-390	-	403/252	462/311	462/317	420/270
2x Z-50-FB-600	-	377/239	436/298	436/304	394/257
2x Z-50-FB-1000	-	493/297	552/356	552/362	510/315
2x Z-50-FB-1200	-	483/292	542/351	542/357	500/310
2x Z-50-FB-1500	-	593/347	652/406	652/412	610/365

Detailed instructions for determining the length can be found in Section 8

50 kN

Technical data series Z-50-S / Z-50-R

max. compressive/tensile force, static	- 50 kN (5 t)
max. compressive/tensile force, dynamic	- see duty cycle curves
Nominal speed	- 1500 rpm
max. drive shaft speed	- 1800 rpm
Screw size standard	- Tr 40x7 ²⁾
Gear ratio	- 7:1 (N) / 28:1 (L)
Housing material	- GGG-50, corrosion-resistant
Worm shaft	- steel, case-hardened, ground
Weight of screw jack body	- 17 kg
Weight of screw/m	- 8 kg
Gearbox lubrication	- synthetic fluid grease
Screw lubrication	- grease lubrication
Gearbox operating temperature	- max. 60°C, higher on request
Moment of inertia	- N: 6.40 kg cm ² / L: 2.53 kg cm ²
Input torque (at 1500 rpm)	- max. 31.5 Nm (N) / max. 10.4 Nm (L)
Drive-through torque	- max. 260 Nm

Drive torque M_0 (Nm)	- F (kN) \times 0.68 ³⁾⁵⁾ + M_L (N-normal) - F (kN) \times 0.23 ³⁾⁵⁾ + M_L (L-low speed)
Breakaway torque	- Drive torque M_0 \times 1.5
Idling torque ⁴⁾ M_L (Nm)	- 0.76 (N-normal) / 0.54 (L-low speed)

Between gearbox and nut or nut and end of thread, provide for a safety distance of (minimum) 10 mm!

See Section 7 for the checklist.

Important information

- 1) - extension if a bellows or spiral spring is fitted: see the table or Section 8
- 2) - Tr 40x7 is standard, also available: double-pitch, stainless steel, left-handed, increased screw Tr 55x9 (only for the R version)
- 3) - factor includes efficiency, ratio and 30% safety
- 4) - at 20°C, can be higher when new
- 5) - for a 7 mm screw pitch



Z-50/Tr50-S translating screw 50 kN

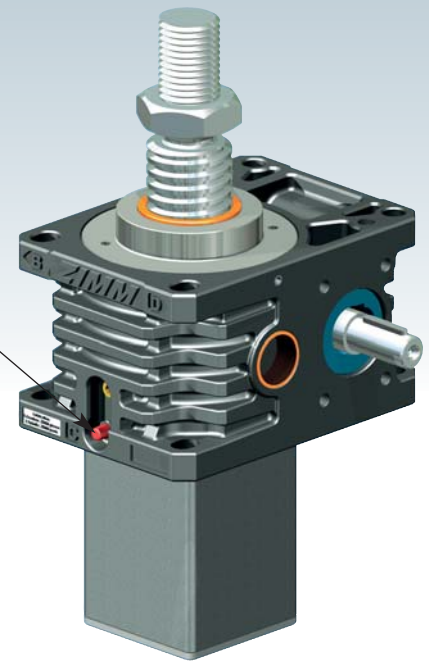

UNIQUE:
Screw lubrication
during operation

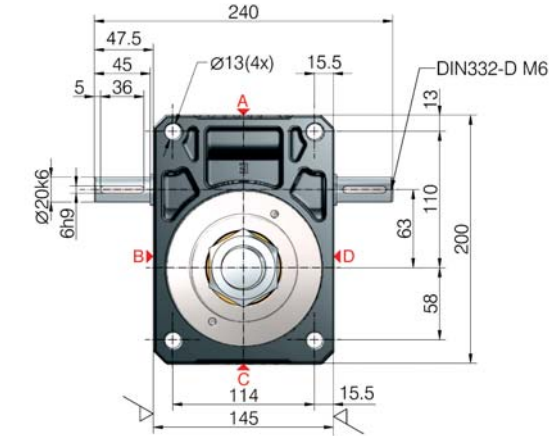
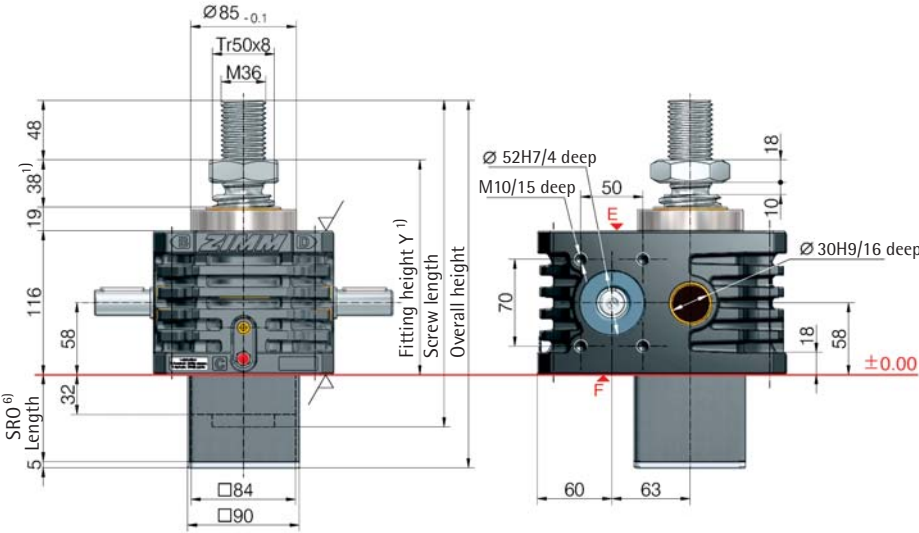

i For Z-50/Tr50, use screw-related accessories from the Z-100.

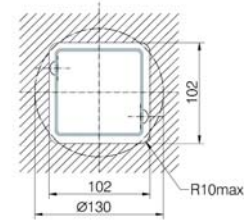

Opening for protective tube SRO
square 102x102
or round Ø130

¹⁾Fitting height for 0-stroke, with Tr 50x8 screw

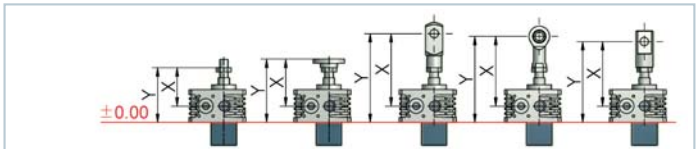

All dimensions in mm

Bellocs FB	X/Y	X/Y	X/Y	X/Y	X/Y
without bellocs FB	115/173	165/223	259/317	257/315	223/281
Z-100-FB-285	198/256	200/258	342/400	340/398	258/316
Z-100-FB-600	195/253	197/255	339/397	337/395	255/313
Z-100-FB-1000	253/311	255/313	397/455	395/453	313/371
Z-100-FB-1500	303/361	305/363	447/505	445/503	363/421

*with bellows fixing ring Z-100-FBR

⁶⁾Protective tube length SRO with Tr 50x8 screw

Without escape/rotation protection	Escape/rotation protection	Rotation protection, with limit switch set ES
62+stroke	92+stroke	144+stroke

Standard ratios

Type	Version	Speed	Standard screw ²⁾	i	Stroke per drive shaft rotation ⁵⁾
Z-50/Tr50-SN	Translating	Normal	Tr 50x8	7:1	1.143 mm
Z-50/Tr50-SL	screw	Low speed		28:1	0.286 mm

Screw jack mounting



Duty cycle thermal limit, for S

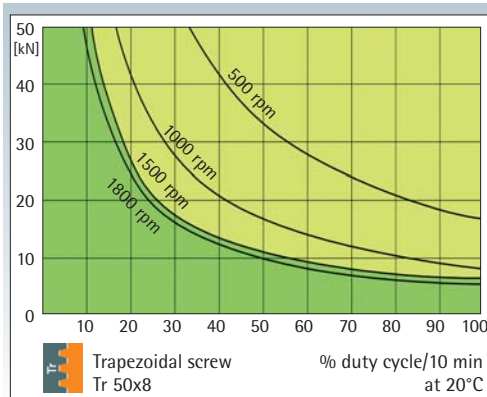

These curves are for guidance under standard industrial conditions (ambient temperature etc.) and correct maintenance (lubrication etc.). The max. input drive torques for optimum service life are at the right page - technical data (1500 rpm)

KGK:
% duty cycle
2 times to
4 times higher

Z-35 + Z-50/Tr50 heavy duty screws for long strokes

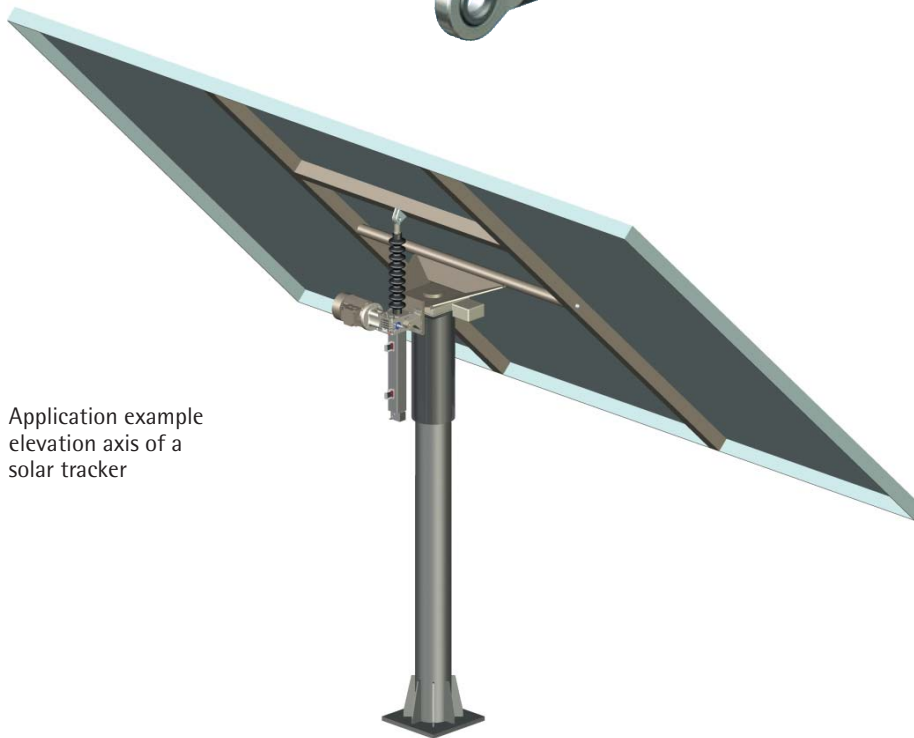
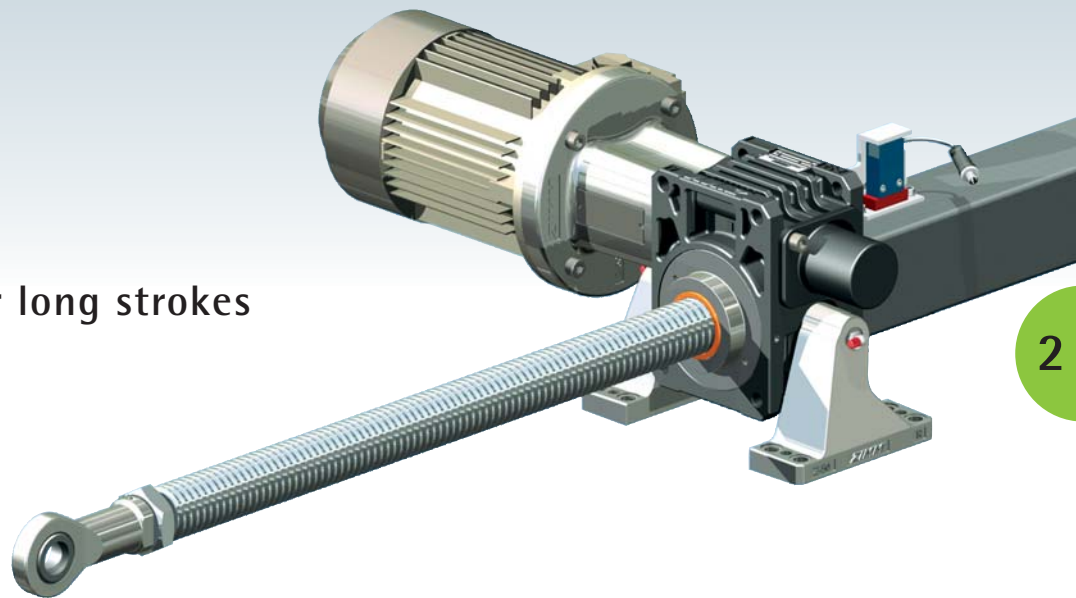

Application example
elevation axis of a
solar tracker

Heavy duty screws

The screw diameter is a critical factor in long-stroke applications. Long-stroke screws have to be oversized to prevent buckling and other problems. However, increasing the diameter of the screw means that the gearbox also has to be oversized accordingly.

To overcome this problem, the Z-35 and the Z-50/Tr50 are specially designed with stronger screws to prevent buckling on applications with long strokes. The screw does not therefore require oversizing and consequently a compact gearbox can also be used on long-stroke applications.

Z-35: with Tr 40x7 screw
Z-50/Tr50: with Tr 50x8 screw

50

kN

Technical data series Z-50/Tr50-S

max. compressive/tensile force, static	- 50 kN (5 t)
max. compressive/tensile force, dynamic	- see duty cycle curves
Nominal speed	- 1500 rpm
max. drive shaft speed	- 1800 rpm
Screw size standard	- Tr 50x8 ²⁾
Gear ratio	- 7:1 (N) / 28:1 (L)
Housing material	- GGG-50, corrosion-resistant
Worm shaft	- steel, case-hardened, ground
Weight of screw jack body	- 17 kg
Weight of screw/m	- 13 kg
Gearbox lubrication	- synthetic fluid grease
Screw lubrication	- grease lubrication
Gearbox operating temperature	- max. 60°C, higher on request
Moment of inertia	- N: 6.65 kg cm ² / L: 2.62 kg cm ²
Input torque (at 1500 rpm)	- max. 31.5 Nm (N) / max. 10.4 Nm (L)
Drive-through torque	- max. 260 Nm

Drive torque M_G (Nm)	- F (kN) \times 0.86 ³⁾⁵⁾ + M_L (N-normal)
Breakaway torque	- F (kN) \times 0.29 ³⁾⁵⁾ + M_L (L-low speed)
Idling torque ⁴⁾ M_L (Nm)	- Drive torque M_G \times 1.5
	- 0.76 (N-normal) / 0.54 (L-low speed)

Between gearbox and nut or nut and end of thread, provide for a safety distance of (minimum) 10 mm!
See Section 7 for the checklist.

Important information

- 1) - extension if a bellows or spiral spring is fitted: see the table or Section 8
- 2) - Tr 50x8 is standard, also available: double-pitch, stainless steel, left-handed
- 3) - factor includes efficiency, ratio and 30% safety
- 4) - at 20°C, can be higher when new
- 5) - for a 8 mm screw pitch



Z-100-S translating screw 100 kN

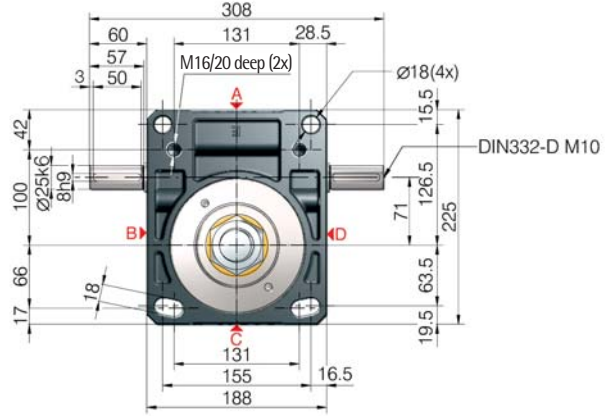
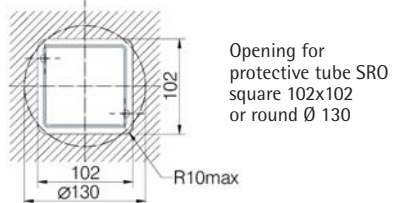
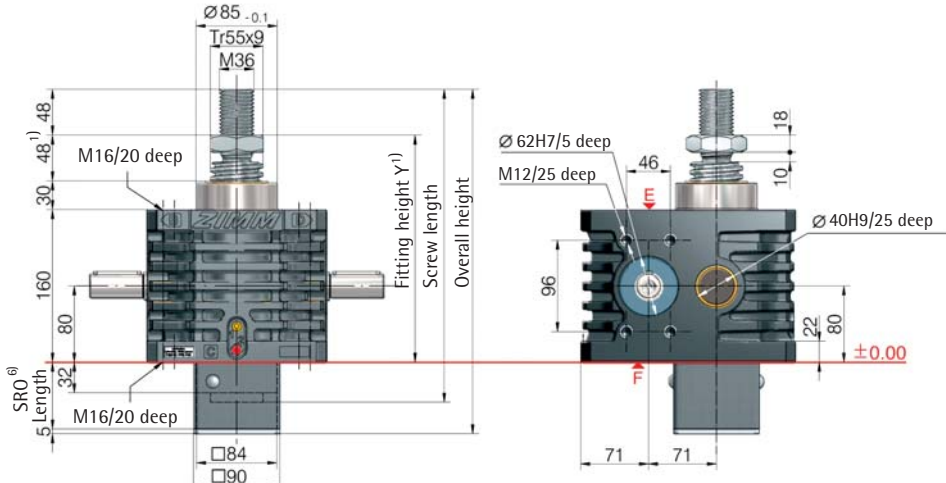
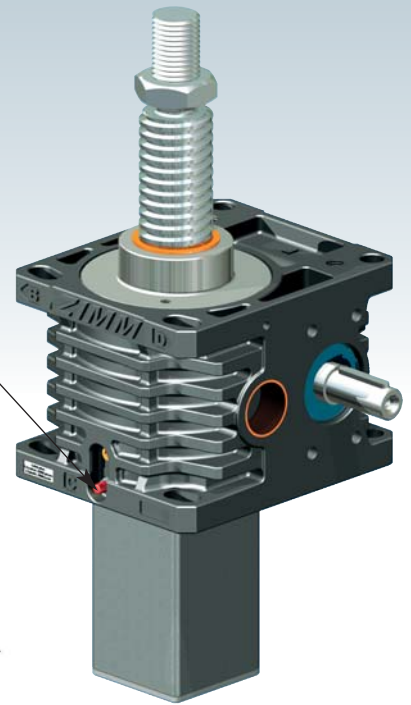

¹⁾Fitting height for 0-stroke, with Tr 55x9 screw

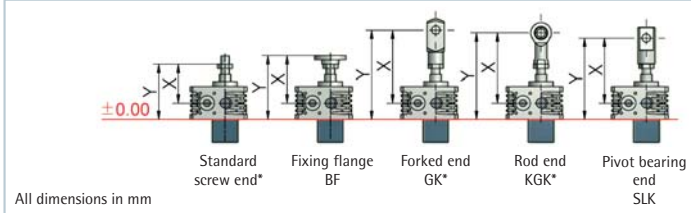

All dimensions in mm

Bellocs FB	X/Y	X/Y	X/Y	X/Y	X/Y
without bellocs FB	158/238	208/288	302/382	300/380	266/346
Z-100-FB-285	231/311	233/313	375/455	373/453	291/371
Z-100-FB-600	228/308	230/310	372/452	370/450	288/368
Z-100-FB-1000	286/366	288/368	430/510	428/508	346/426
Z-100-FB-1500	336/416	338/418	480/560	478/558	396/476

*with bellows fixing ring Z-100-FBR

⁶⁾Protective tube length SRO with Tr 55x9 screw

Without escape/rotation protection	Escape/rotation protection	Rotation protection, with limit switch set ES
82+stroke	112+stroke	144+stroke

Standard ratios

Type	Version	Speed	Standard screw ²⁾	i	Stroke per drive shaft rotation ⁵⁾
Z-100-SN	Translating	Normal	Tr 55x9	9:1	1.00 mm
Z-100-SL	screw	Low speed		36:1	0.25 mm
Z-100-RN	Rotating	Normal	Tr 55x9	9:1	1.00 mm
Z-100-RL	screw	Low speed		36:1	0.25 mm

Screw jack mounting



Duty cycle thermal limit, for S+R

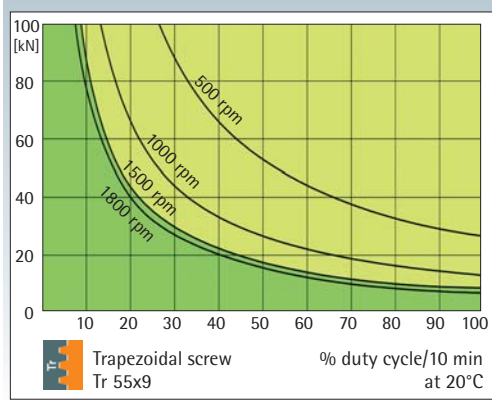

These curves are for guidance under standard industrial conditions (ambient temperature etc.) and correct maintenance (lubrication etc.). The max. input drive torques for optimum service life are at the right page - technical data (1500 rpm)

KGT: % duty cycle 2 times to 4 times higher

Trapezoidal screw

Tr



Z-100-R rotating screw 100 kN

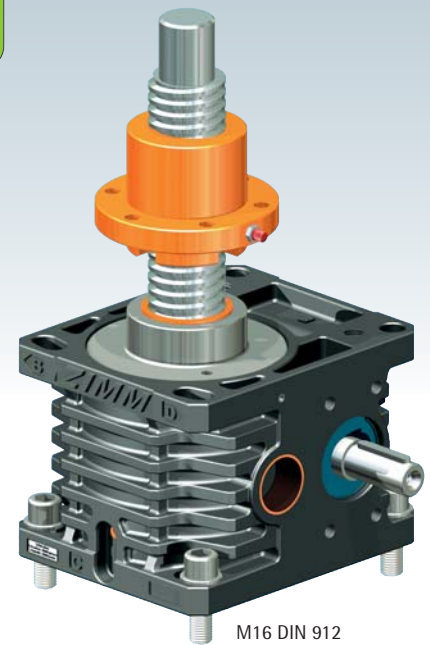
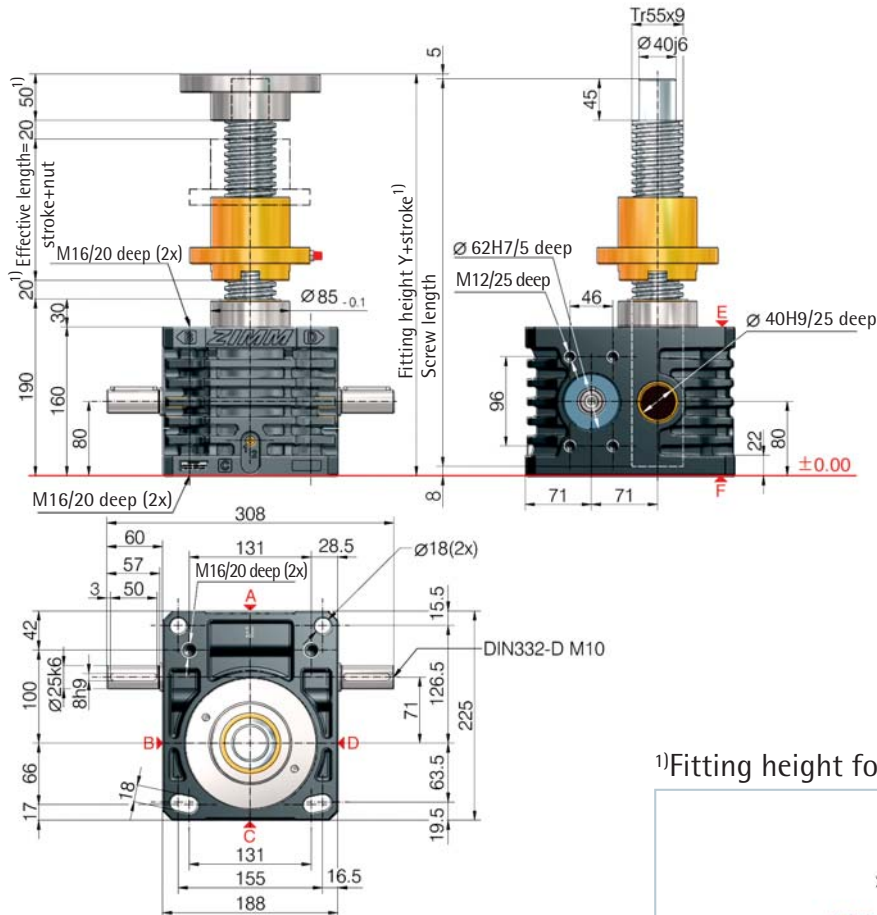

M16 DIN 912

¹⁾Fitting height for 0-stroke, with Tr 55x9 screw

All dimensions in mm	Duplex nut DM	Duplex nut DM with SIFA	Self-aligning nut PM
Bellows FB	Y/A	Y/A	Y/A
without bellows FB	370/246	453/329	470/355
2x Z-100-FB-285	478/299	556/377	578/408
2x Z-100-FB-600	472/296	550/374	572/405
2x Z-100-FB-1000	588/354	666/432	688/463
2x Z-100-FB-1500	688/404	766/482	788/513

Detailed instructions for determining the length can be found in Section 8

100 kN

Technical data series Z-100-S / Z-100-R

max. compressive/tensile force, static	- 100 kN (10 t)
max. compressive/tensile force, dynamic	- see duty cycle curves
Nominal speed	- 1500 rpm
max. drive shaft speed	- 1800 rpm
Screw size standard	- Tr 55x9 ²⁾
Gear ratio	- 9:1 (N) / 36:1 (L)
Housing material	- GGG-50, corrosion-resistant
Worm shaft	- steel, case-hardened, ground
Weight of screw jack body	- 29 kg
Weight of screw/m	- 15.7 kg
Gearbox lubrication	- synthetic fluid grease
Screw lubrication	- grease lubrication
Gearbox operating temperature	- max. 60°C, higher on request
Moment of inertia	- N: 12.53 kg cm ² / L: 4.75 kg cm ²
Input torque (at 1500 rpm)	- max. 53.4 Nm (N) / max. 13.5 Nm (L)
Drive-through torque	- max. 540 Nm

Drive torque M_G (Nm)	- F (kN) \times 0.72 ³⁾⁵⁾ + M_L (N-normal)
Breakaway torque	- F (kN) \times 0.23 ³⁾⁵⁾ + M_L (L-low speed)
Idling torque ⁴⁾ M_L (Nm)	- Drive torque M_G \times 1.5
	- 1.68 (N-normal) / 1.02 (L-low speed)

Between gearbox and nut or nut and end of thread, provide for a safety distance of (minimum) 20 mm!

See Section 7 for the checklist.

Important information

- 1) - extension if a bellows or spiral spring is fitted: see the table or Section 8
- 2) - Tr 55x9 is standard, also available: double-pitch, stainless steel, left-handed, increased screw Tr 60x9 (only for the R version)
- 3) - factor includes efficiency, ratio and 30% safety
- 4) - at 20°C, can be higher when new
- 5) - for a 9 mm screw pitch



Z-150-S translating screw 150 kN

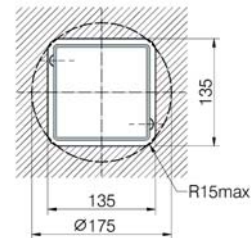
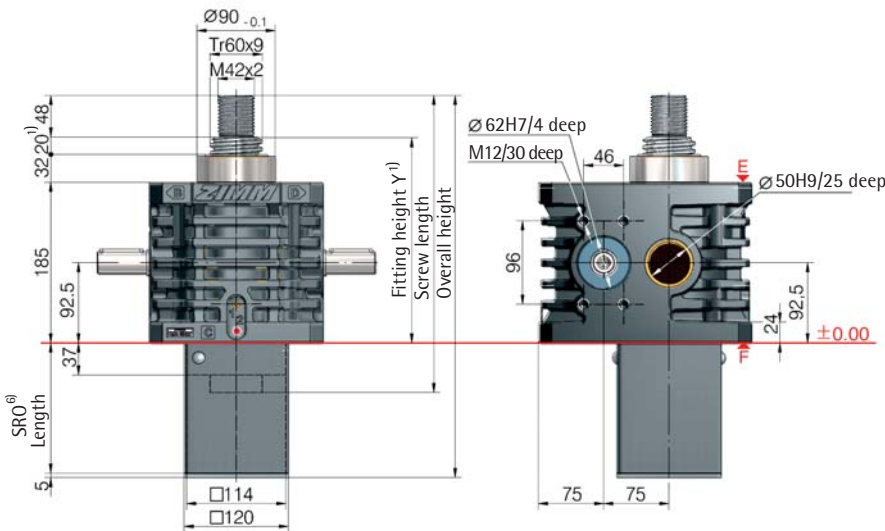
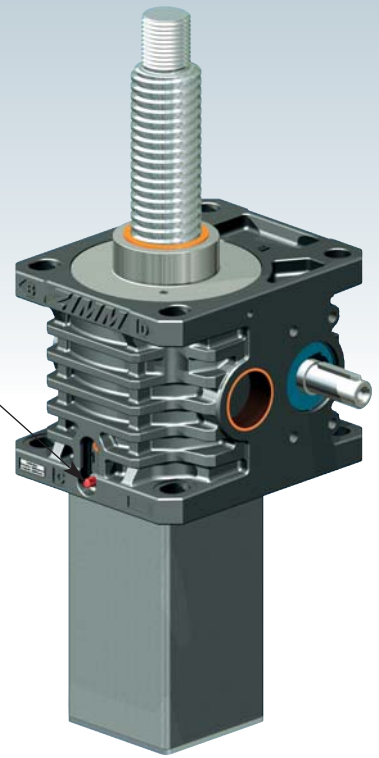

Opening for protective tube SRO square 135x135 or round Ø 175

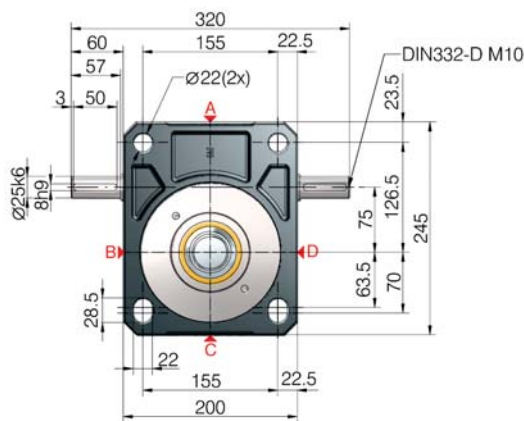

¹)Fitting height for 0-stroke, with Tr 60x9 screw

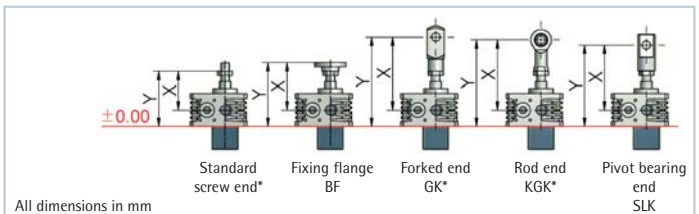

All dimensions in mm

Bellocs FB	X/Y	X/Y	X/Y	X/Y	X/Y
without bellocs FB	145/237	195/287	313/405	305/397	300/392
Z-150-FB-350	198/290	223/315	366/458	358/450	328/420
Z-150-FB-600	220/312	245/337	388/480	380/472	350/442
Z-150-FB-1000	278/370	303/395	446/538	438/530	408/500
Z-150-FB-1500	328/420	353/445	496/588	488/580	458/550

*with bellows fixing ring Z-150-FBR

⁶)Protective tube length SRO with Tr 60x9 screw

Without escape/rotation protection	Escape/rotation protection	Rotation protection, with limit switch set ES
87+stroke	117+stroke	149+stroke

Standard ratios

Type	Version	Speed	Standard screw ²⁾	i	Stroke per drive shaft rotation ⁵⁾
Z-150-SN	Translating	Normal	Tr 60x9	9:1	1.00 mm
Z-150-SL	screw	Low speed		36:1	0.25 mm
Z-150-RN	Rotating	Normal	Tr 60x9	9:1	1.00 mm
Z-150-RL	screw	Low speed		36:1	0.25 mm

Screw jack mounting



Duty cycle thermal limit, for S+R

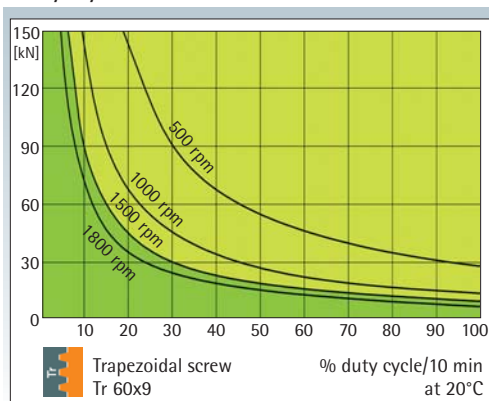

These curves are for guidance under standard industrial conditions (ambient temperature etc.) and correct maintenance (lubrication etc.). The max. input drive torques for optimum service life are at the right page - technical data (1500 rpm)

KGT: % duty cycle 2 times to 4 times higher

Trapezoidal screw

Tr



Z-150-R rotating screw 150 kN

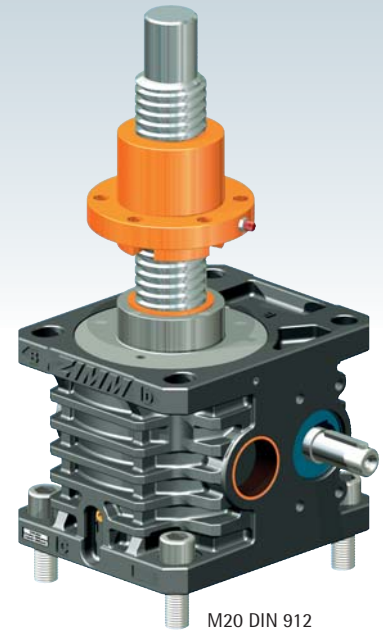
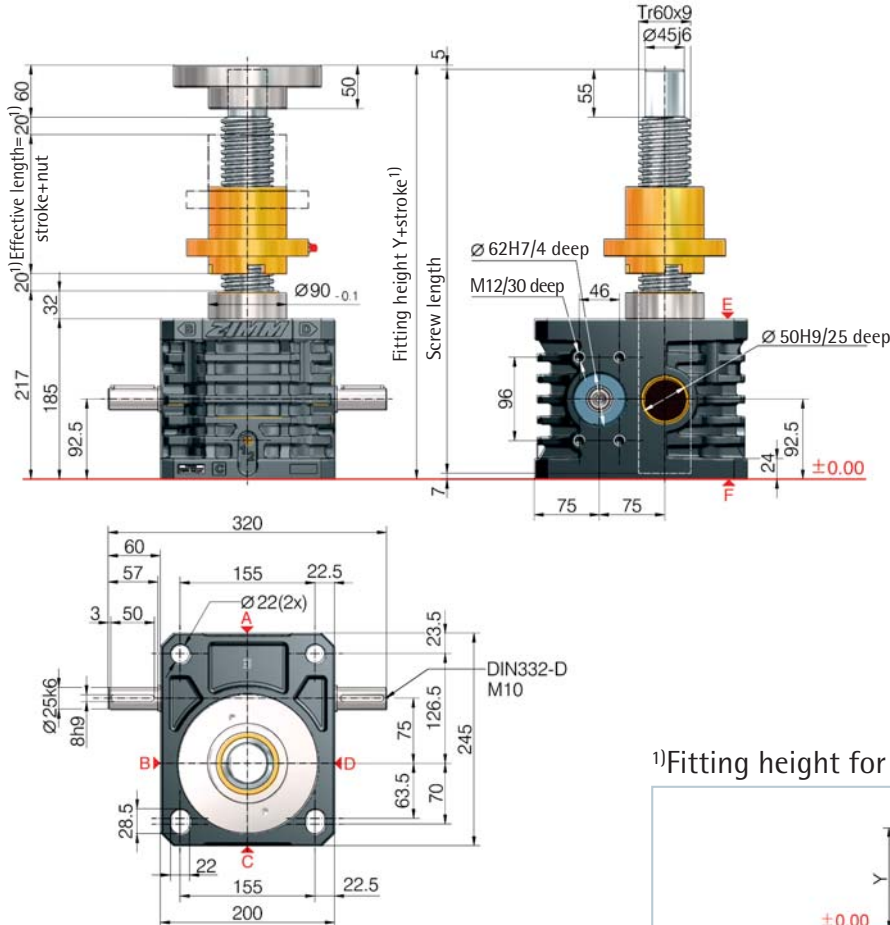

¹⁾Fitting height for 0-stroke, with Tr 60x9 screw

All dimensions in mm	Duplex nut DM	Duplex nut DM with SIFA	Self-aligning nut PM
	Y/A	Y/A	Y/A
Bellows FB			
without bellows FB	432/277	528/373	527/402
2x Z-150-FB-300	480/305	571/396	575/430
2x Z-150-FB-600	524/327	615/418	619/452
2x Z-150-FB-1000	640/385	731/476	735/510
2x Z-150-FB-1500	740/435	831/526	835/560

Detailed instructions for determining the length can be found in Section 8

150 kN

Technical data series Z-150-S / Z-150-R

max. compressive/tensile force, static	- 150 kN (15 t)
max. compressive/tensile force, dynamic	- see duty cycle curves
Nominal speed	- 1500 rpm
max. drive shaft speed	- 1800 rpm
Screw size standard	- Tr 60x9 ²⁾
Gear ratio	- 9:1 (N) / 36:1 (L)
Housing material	- GGG-50, corrosion-resistant
Worm shaft	- steel, case-hardened, ground
Weight of screw jack body	- 42 kg
Weight of screw/m	- 19 kg
Gearbox lubrication	- synthetic fluid grease
Screw lubrication	- grease lubrication
Gearbox operating temperature	- max. 60°C, higher on request
Moment of inertia	- N: 22.47 kg cm ² / L: 7.96 kg cm ²
Input torque (at 1500 rpm)	- max. 75.1 Nm (N) / max. 20.7 Nm (L)
Drive-through torque	- max. 540 Nm

Drive torque M_G (Nm)	- F (kN) \times 0.75 ³⁾ + M_L (N-normal)
Breakaway torque	- F (kN) \times 0.25 ³⁾ + M_L (L-low speed)
Idling torque ⁴⁾ M_L (Nm)	- Drive torque M_G \times 1.5
	- 1.90 (N-normal) / 1.20 (L-low speed)

Between gearbox and nut or nut and end of thread, provide for a safety distance of (minimum) 20 mm!

See Section 7 for the checklist.

Important information

- extension if a bellows or spiral spring is fitted: see the table or Section 8
- Tr 60x9 is standard, also available: double-pitch, stainless steel, left-handed, increased screw Tr 80x16 (only for the R version)
- factor includes efficiency, ratio and 30% safety
- at 20°C, can be higher when new
- for a 9 mm screw pitch



Z-250-R rotating screw 250 kN

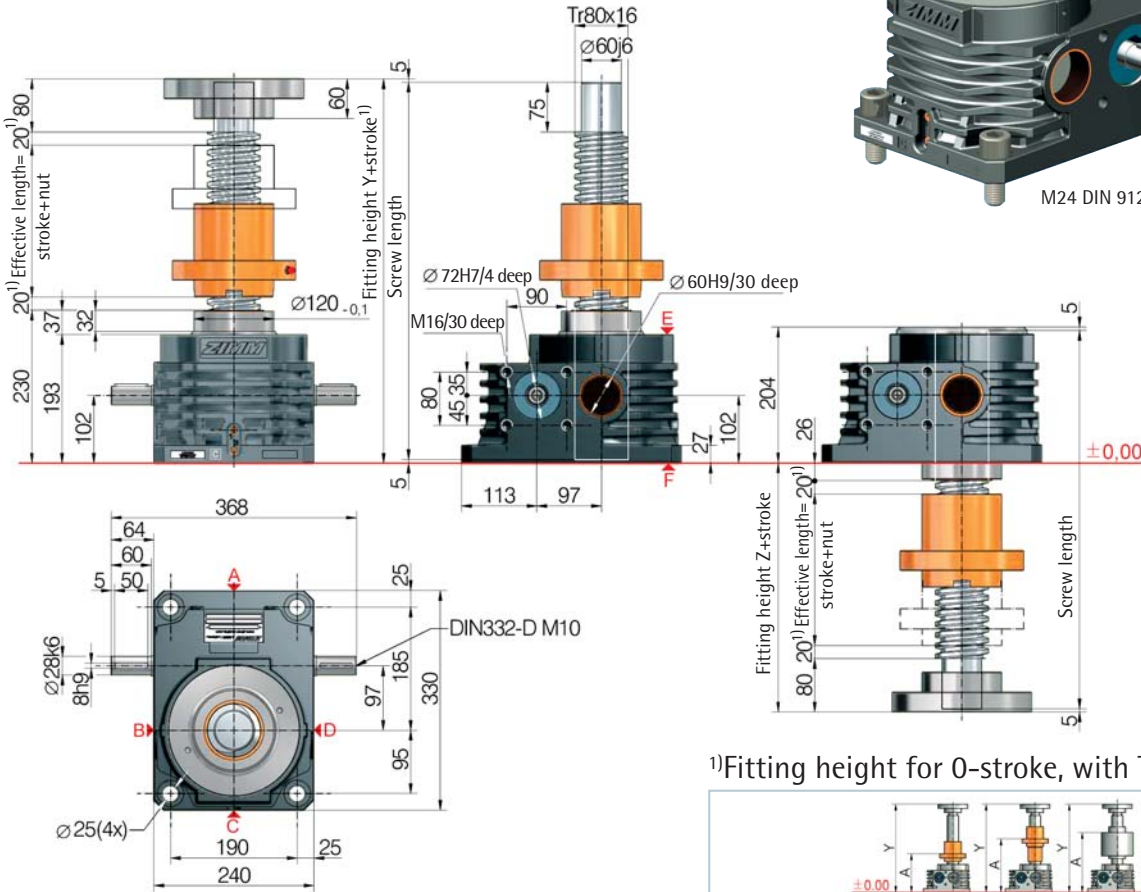
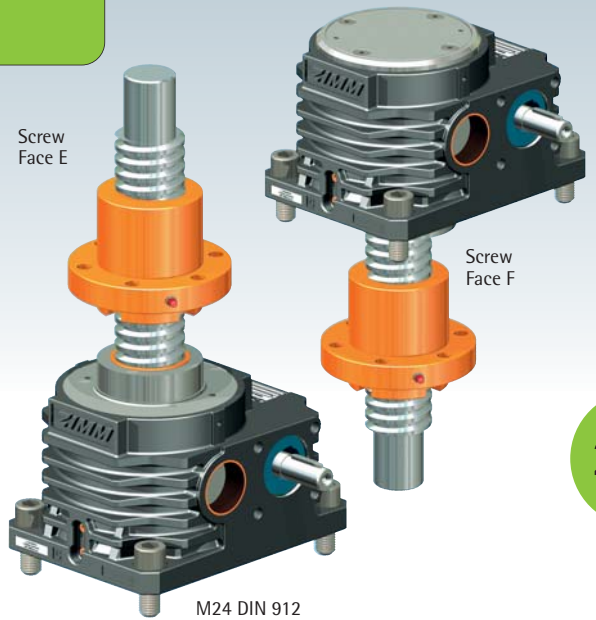

1) Fitting height for 0-stroke, with Tr 80x16 screw

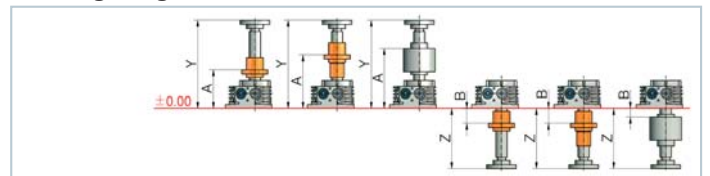

All dimensions in mm	DM	DM with SIFA	PM	DM	DM with SIFA	DM
Bellows FB	Y/A	Y/A	Y/A	Z/B	Z/B	Z/B
without bellows FB	490/305	600/415	574/434	286/131	396/131	370/86
2x Z-250-FB-390	608/373	712/477	692/502	404/199	514/199	488/154
2x Z-250-FB-600	572/355	676/459	656/484	368/181	478/181	452/136
2x Z-250-FB-1000	688/413	792/517	772/542	484/239	594/239	568/194
2x Z-250-FB-1500	788/463	892/567	872/592	584/289	694/289	668/244

Detailed instructions for determining the length can be found in Section 8

250 kN

Technical data series Z-250-S / Z-250-R

max. compressive/tensile force, static	- 250 kN (25 t)
max. compressive/tensile force, dynamic	- see duty cycle curves
Nominal speed	- 1500 rpm
max. drive shaft speed	- 1800 rpm
Screw size standard	- Tr 80x16 ²⁾
Gear ratio	- 10.66:1 (N) / 32:1 (L)
Housing material	- GGG-50, corrosion-resistant
Worm shaft	- steel, case-hardened, ground
Weight of screw jack body	- 59 kg
Weight of screw/m	- 32 kg
Gearbox lubrication	- synthetic gear oil
Screw lubrication	- grease lubrication
Gearbox operating temperature	- max. 60°C, higher on request
Moment of inertia	- N: 53.8 kg cm ² / L: 22.0 kg cm ²
Input torque (at 1500 rpm)	- max. 152 Nm (N) / max. 41.4 Nm (L)
Drive-through torque	- max. 770 Nm

Drive torque M_G (Nm)	- F (kN) \times 0.94 ³⁾ + M_L (N-normal)
	- F (kN) \times 0.37 ³⁾ + M_L (L-low speed)
Breakaway torque	- Drive torque M_G \times 1.5
Idling torque ⁴⁾ M_L (Nm)	- 2.64 (N-normal) / 1.94 (L-low speed)

Between gearbox and nut or nut and end of thread, provide for a safety distance of (minimum) 20 mm!
See Section 7 for the checklist.

Important information

- extension if a bellows or spiral spring is fitted: see the table or Section 8
- Tr 80x16 is standard, also available: double-pitch, stainless steel, left-handed, increased screw Tr 100x16 (only for the R version)
- factor includes efficiency, ratio and 30% safety
- at 20°C, can be higher when new
- for a 16 mm screw pitch



Z-350-S translating screw 350 kN

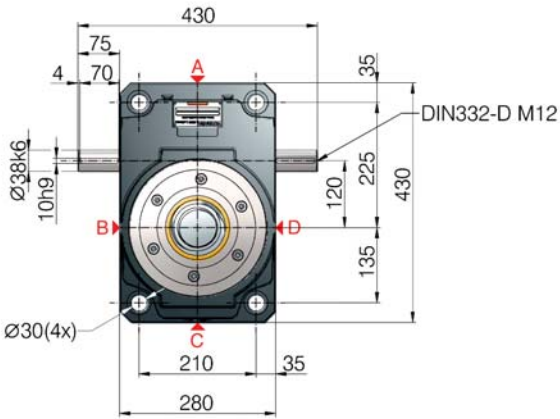
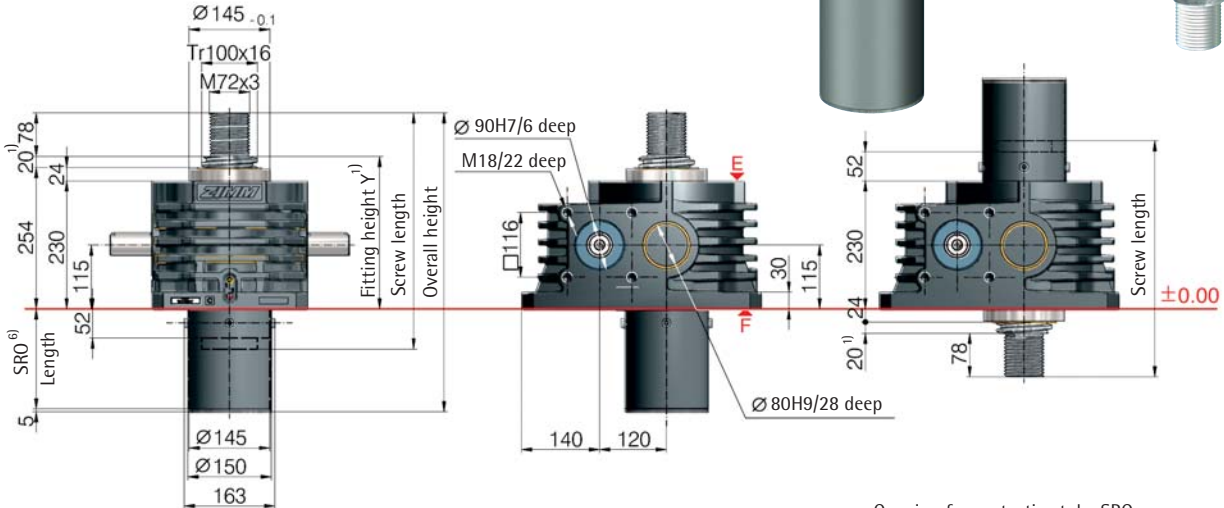
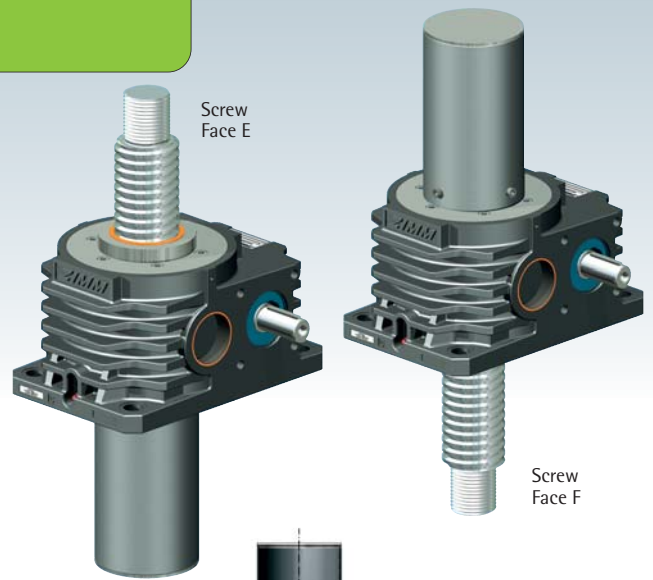

Opening for protective tube SRO

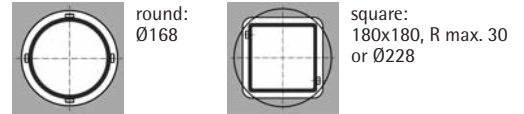

¹⁾Fitting height for 0-stroke, with Tr 100x16 screw

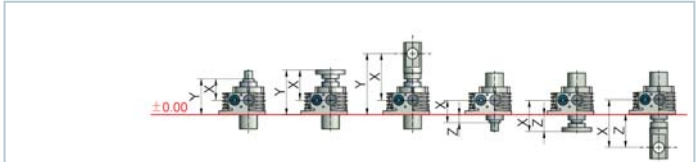

⁶⁾Protective tube length SRO with Tr 100x16 screw

only screw	with escape protection AS	with rotation protection VS	with VS and limit switch set ES
○ Ø150	○ Ø150	□ 160x160	□ 160x160
107+stroke	142+stroke	142+stroke	166+stroke

All dimensions in mm	BF		SLK		BF		SLK	
	X/Y	X/Y	X/Y	X/Z	X/Z	X/Z	X/Z	
Bellocs FB								
without bellocs FB	159/274	239/354	354/469	159/44	239/124	354/239		
Z-350-FB-600	262/377	317/432	432/547	262/147	317/202	432/317		
Z-350-FB-900	270/385	325/440	440/555	270/155	325/210	440/325		
Z-350-FB-1500	342/457	397/512	512/627	342/227	397/282	512/397		

Standard ratios

Type	Version	Speed	Standard screw ²⁾	i	Stroke per drive shaft rotation ⁵⁾
Z-350-SN	Translating	Normal	Tr 100x16	10.66:1	1.5 mm
Z-350-SL	screw	Low speed		32:1	0.5 mm
Z-350-RN	Rotating	Normal	Tr 100x16	10.66:1	1.5 mm
Z-350-RL	screw	Low speed		32:1	0.5 mm

Screw jack mounting



Duty cycle thermal limit, for S+R

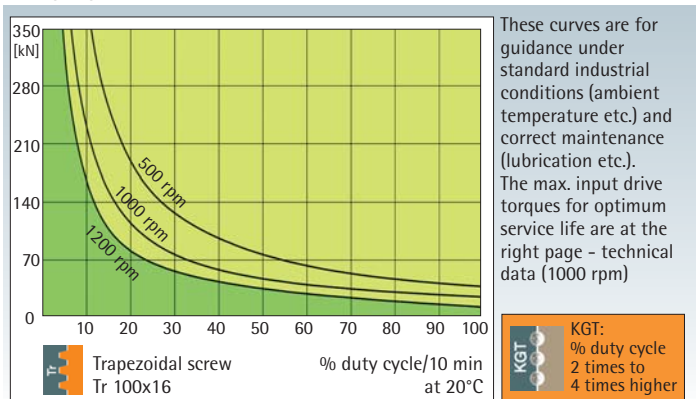

Trapezoidal screw

Tr

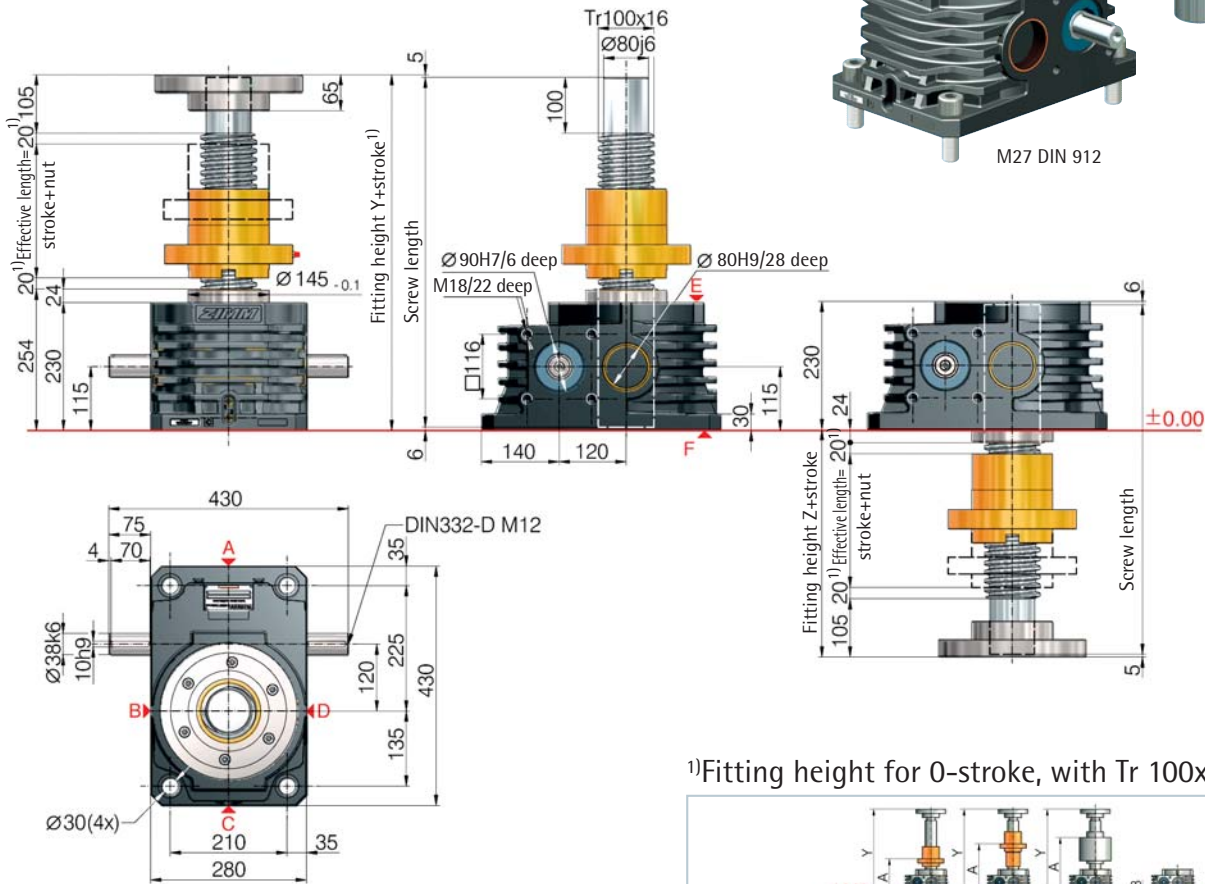
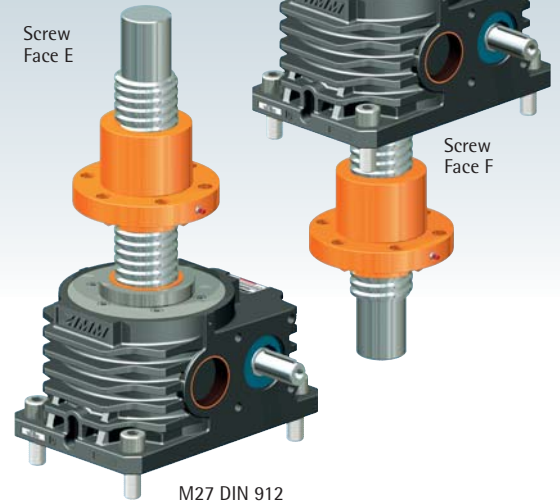

Z-350-R rotating screw 350 kN

Screw
Face EScrew
Face F

M27 DIN 912

1) Fitting height for 0-stroke, with Tr 100x16 screw

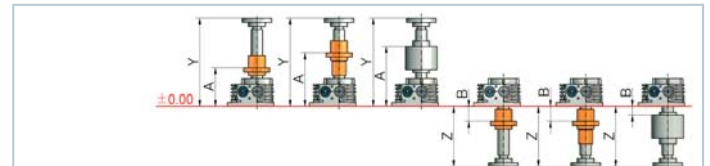

All dimensions in mm	DM	DM with SIFA	PM	DM	DM with SIFA	DM
Bellows FB	Y/A	Y/A	Y/A	Z/B	Z/B	Z/B
without bellows FB	559/334	669/444	674/509	329/144	439/144	444/84
2x Z-350-FB-600	677/412	781/516	792/587	447/222	557/222	562/162
2x Z-350-FB-900	693/420	797/524	808/595	463/230	573/230	578/170
2x Z-350-FB-1500	837/492	941/596	952/667	607/302	717/302	722/242

Detailed instructions for determining the length can be found in Section 8

350 kN

Technical data series Z-350-S / Z-350-R

max. compressive/tensile force, static	- 350 kN (35 t)
max. compressive/tensile force, dynamic	- see duty cycle curves
Nominal speed	- 1000 rpm
max. drive shaft speed	- 1200 rpm
Screw size standard	- Tr 100x16 ²⁾
Gear ratio	- 10.66:1 (N) / 32:1 (L)
Housing material	- GGG-50, corrosion-resistant
Worm shaft	- steel, case-hardened, ground
Weight of screw jack body	- 112 kg
Weight of screw/m	- 52 kg
Gearbox lubrication	- synthetic gear oil
Screw lubrication	- grease lubrication
Gearbox operating temperature	- max. 60°C, higher on request
Moment of inertia	- N: 148.9 kg cm ² / L: 66.1 kg cm ²
Input torque (at 1000 rpm)	- max. 265 Nm (N) / max. 100 Nm (L)
Drive-through torque	- max. 1800 Nm

Drive torque M_G (Nm)	- F (kN) \times 1.09 ³⁾⁵⁾ + M_L (N-normal)
Breakaway torque	- F (kN) \times 0.42 ³⁾⁵⁾ + M_L (L-low speed)
Idling torque ⁴⁾ M_L (Nm)	- Drive torque M_G \times 1.5
	- 3.24 (N-normal) / 2.20 (L-low speed)

Between gearbox and nut or nut and end of thread, provide for a safety distance of (minimum) 20 mm!
See Section 7 for the checklist.

Important information

- 1) - extension if a bellows or spiral spring is fitted: see the table or Section 8
- 2) - Tr 100x16 is standard, also available: double-pitch, stainless steel, left-handed, increased screw Tr 120x16 (only for the R version)
- 3) - factor includes efficiency, ratio and 30% safety
- 4) - at 20°C, can be higher when new
- 5) - for a 16 mm screw pitch



Z-500-S translating screw 500 kN

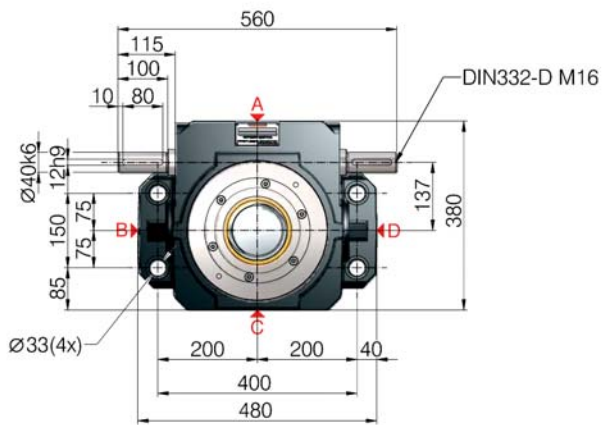
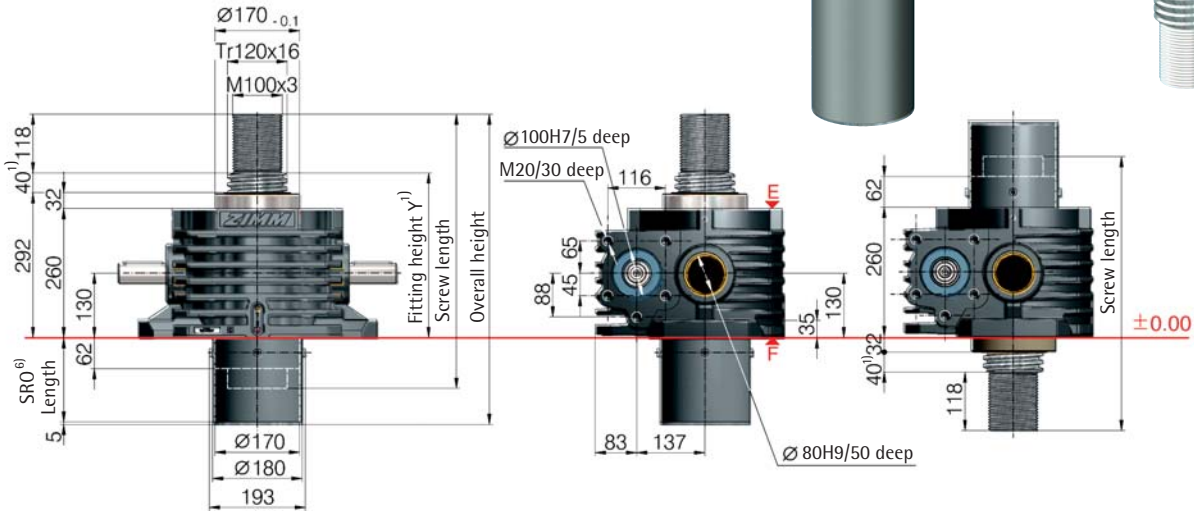
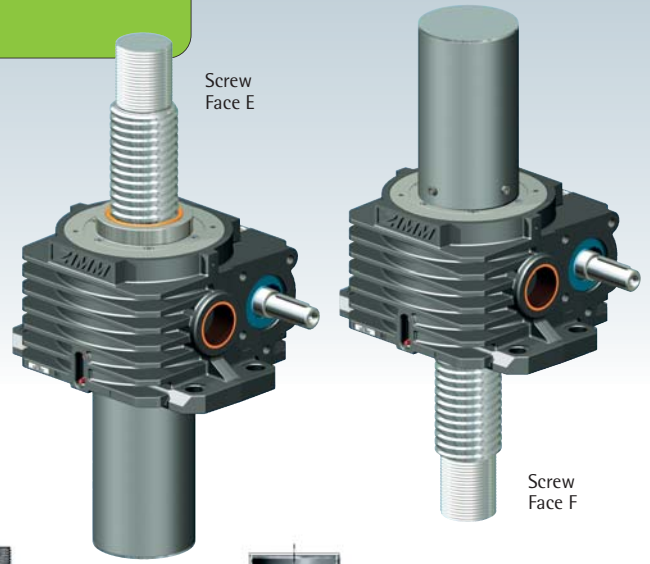

Opening for protective tube SRO

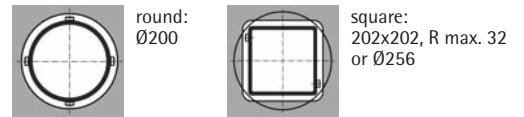

6) Protective tube length SRO with Tr 120x16 screw

only screw	with escape protection AS	with rotation protection VS	with VS and limit switch set ES
○ Ø180	○ Ø180	□ 180x180	□ 180x180
157+stroke	197+stroke	197+stroke	197+stroke

1) Fitting height for 0-stroke, with Tr 120x16 screw

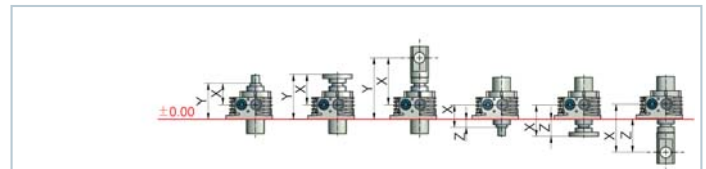

All dimensions in mm	BF		SLK		BF		SLK	
	X/Y	X/Y	X/Y	X/Y	X/Z	X/Z	X/Z	X/Z
without bellows FB	202/332	322/452	447/577	202/72	322/192	447/317		

Standard ratios

Type	Version	Speed	Standard screw ²⁾	i	Stroke per drive shaft rotation ⁵⁾
Z-500-SN	Translating screw	Normal	Tr 120x16	10.66:1	1.5 mm
Z-500-SL		Low speed		32:1	0.5 mm
Z-500-RN	Rotating screw	Normal	Tr 120x16	10.66:1	1.5 mm
Z-500-RL		Low speed		32:1	0.5 mm

Screw jack mounting



Duty cycle thermal limit, for S+R

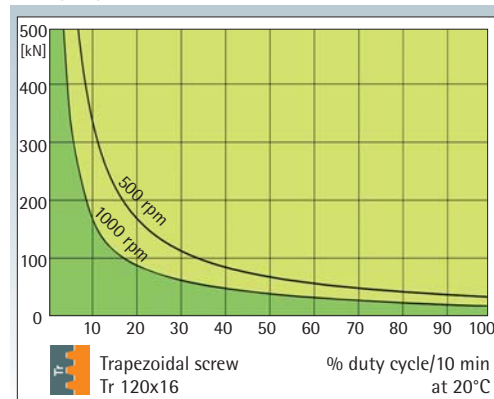

These curves are for guidance under standard industrial conditions (ambient temperature etc.) and correct maintenance (lubrication etc.). The max. input drive torques for optimum service life are at the right page - technical data (1000 rpm)

KGT: % duty cycle 2 times to 4 times higher



Z-500-R rotating screw 500 kN

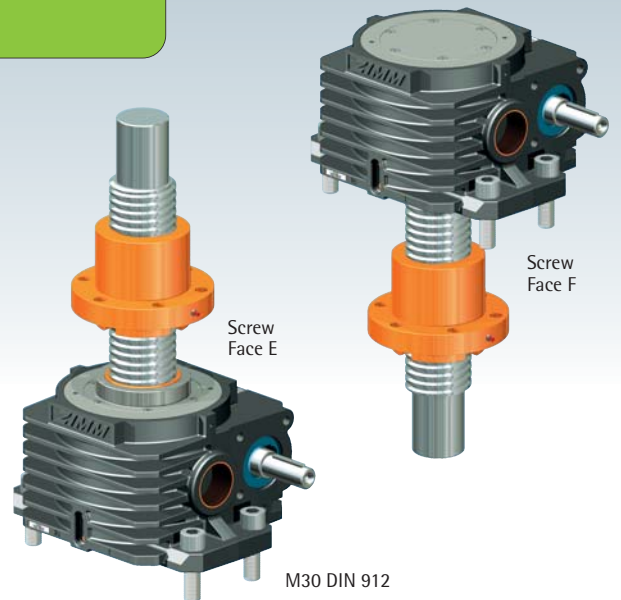
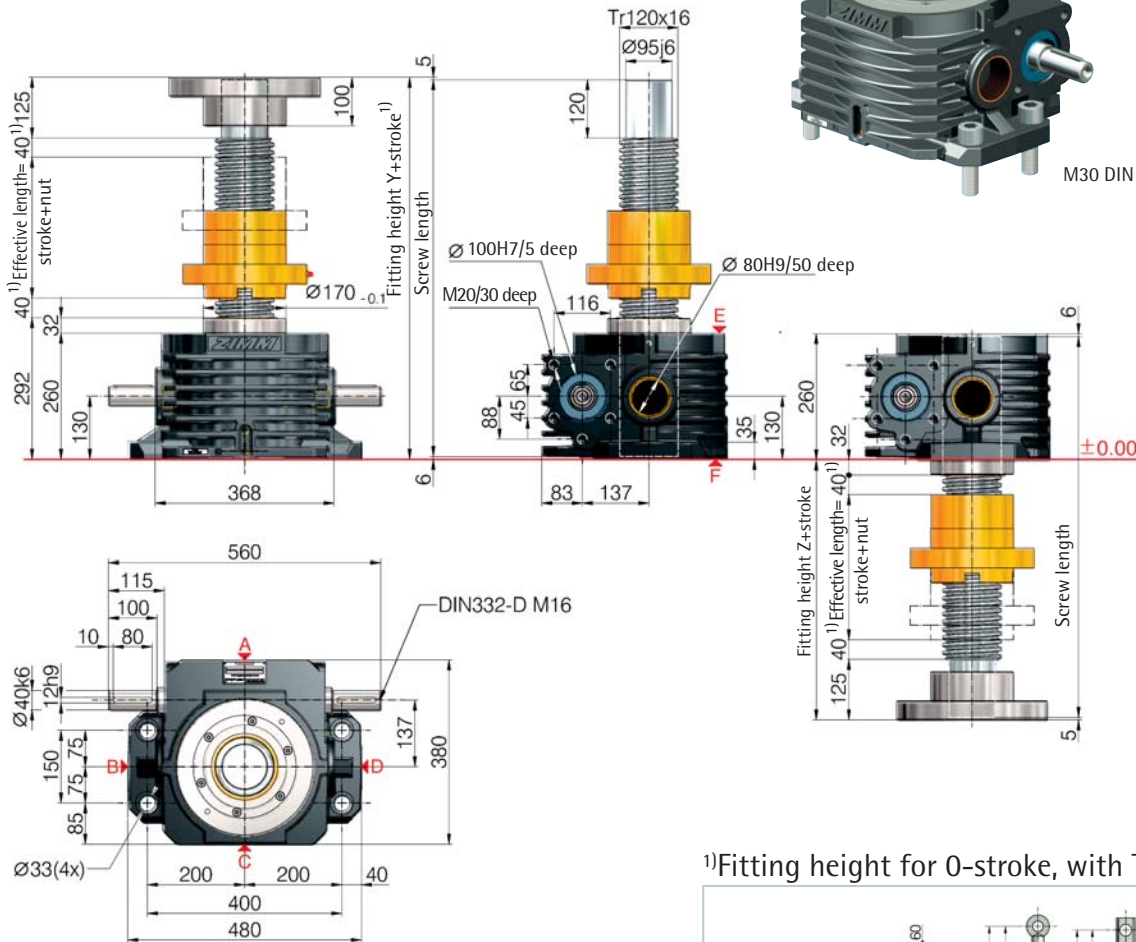

500 kN

1) Fitting height for 0-stroke, with Tr 120x16 screw

All dimensions in mm	DM	DM with SIFA	DM	DM with SIFA
	Y/A	Y/A	Z/B	Z/B
without bellows FB	677/402	800/525	417/182	540/182

Detailed instructions for determining the length can be found in Section 8

Technical data series Z-500-S / Z-500-R

- max. compressive/tensile force, static - 500 kN (50 t)
- max. compressive/tensile force, dynamic - see duty cycle curves
- Nominal speed - 1000 rpm
- max. drive shaft speed - 1000 rpm
- Screw size standard - Tr 120x16²⁾
- Gear ratio - 10.66:1 (N) / 32:1 (L)
- Housing material - GGG-50, corrosion-resistant
- Worm shaft - steel, case-hardened, ground
- Weight of screw jack body - 168 kg
- Weight of screw/m - 77 kg
- Gearbox lubrication - synthetic gear oil
- Screw lubrication - grease lubrication
- Gearbox operating temperature - max. 60°C, higher on request
- Moment of inertia - N: 310.2 kg cm² / L: 127.8 kg cm²
- Input torque (at 1000 rpm) - max. 408 Nm (N) / max. 170 Nm (L)
- Drive-through torque - max. 1940 Nm

- Drive torque M₀ (Nm) - F (kN) x 1.24³⁾⁵⁾ + M_i (N-normal)
- F (kN) x 0.50³⁾⁵⁾ + M_i (L-low speed)
- Breakaway torque - Drive torque M₀ x 1.5
- Idling torque⁴⁾ M_i (Nm) - 3.96 (N-normal) / 2.84 (L-low speed)

Between gearbox and nut or nut and end of thread, provide for a safety distance of (minimum) 40 mm!
See Section 7 for the checklist.

Important information

- extension if a bellows or spiral spring is fitted: see Section 8
- Tr 120x16 is standard, also available: double-pitch, stainless steel, left-handed, increased screw Tr 140x20 (only for the R version)
- factor includes efficiency, ratio and 30% safety
- at 20°C, can be higher when new
- for a 16 mm screw pitch



Z-750-S translating screw 750 kN

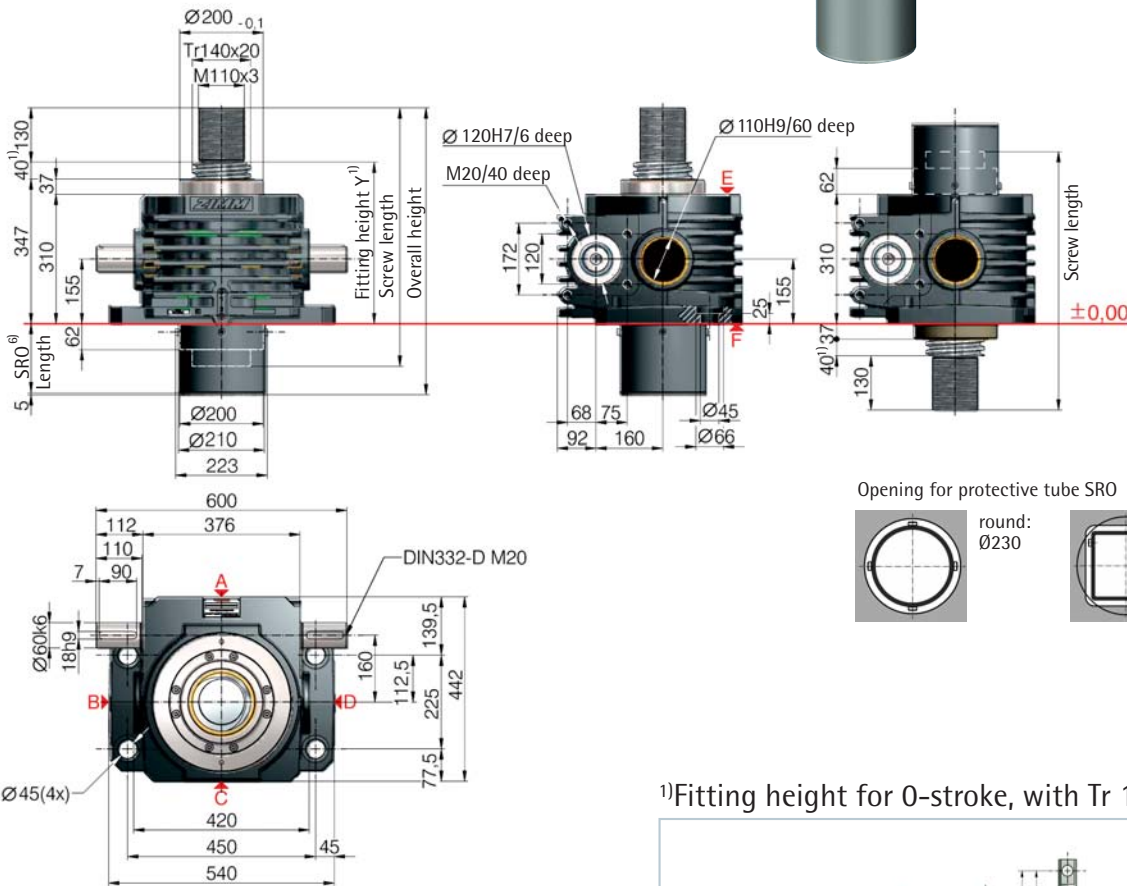
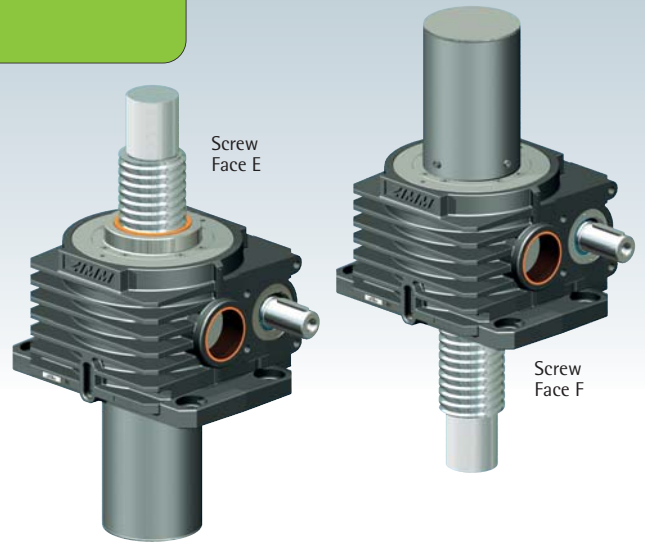

Opening for protective tube SRO

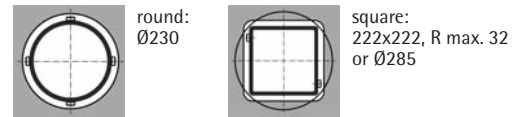

6) Protective tube length SRO with Tr 140x20 screw

only screw	with escape protection AS	with rotation protection VS	with VS and limit switch set ES
○ Ø210	○ Ø210	□ 200x200	□ 200x200
157+stroke	197+stroke	197+stroke	205+stroke

1) Fitting height for 0-stroke, with Tr 140x20 screw

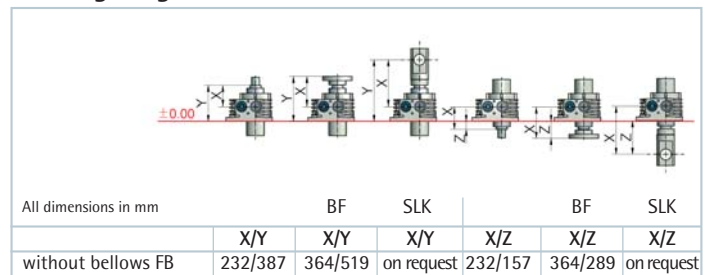

Standard ratios

Type	Version	Speed	Standard screw ²⁾	i	Stroke per drive shaft rotation ⁵⁾
Z-750-SN	Translating	Normal	Tr 140x20	13.33:1	1.5 mm
Z-750-SL	screw	Low speed		40:1	0.5 mm
Z-750-RN	Rotating	Normal	Tr 140x20	13.33:1	1.5 mm
Z-750-RL	screw	Low speed		40:1	0.5 mm

Screw jack mounting



Duty cycle thermal limit, for S+R

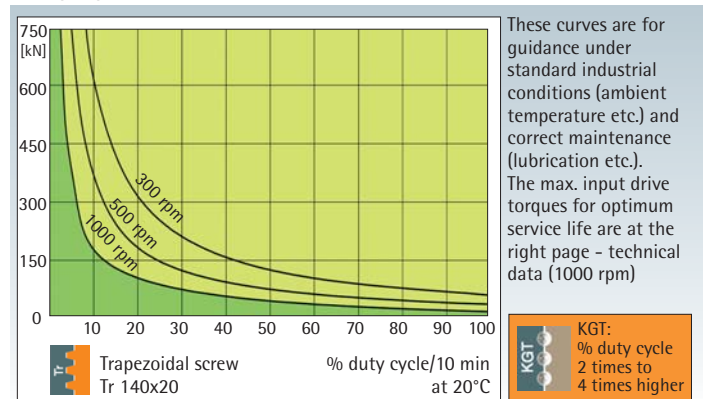

Trapezoidal screw

Tr

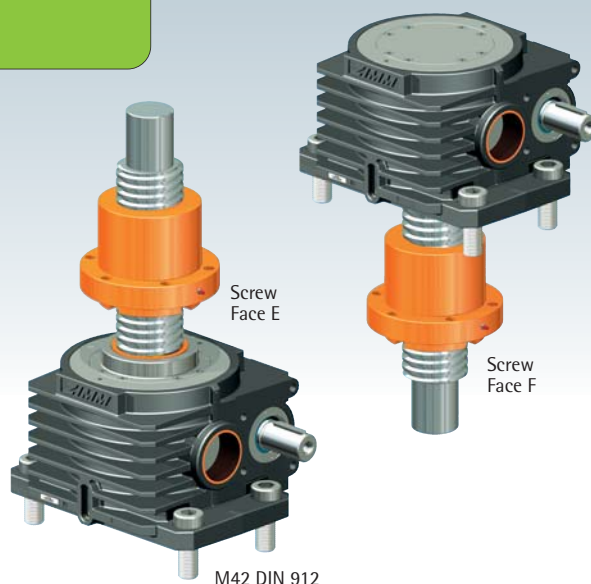
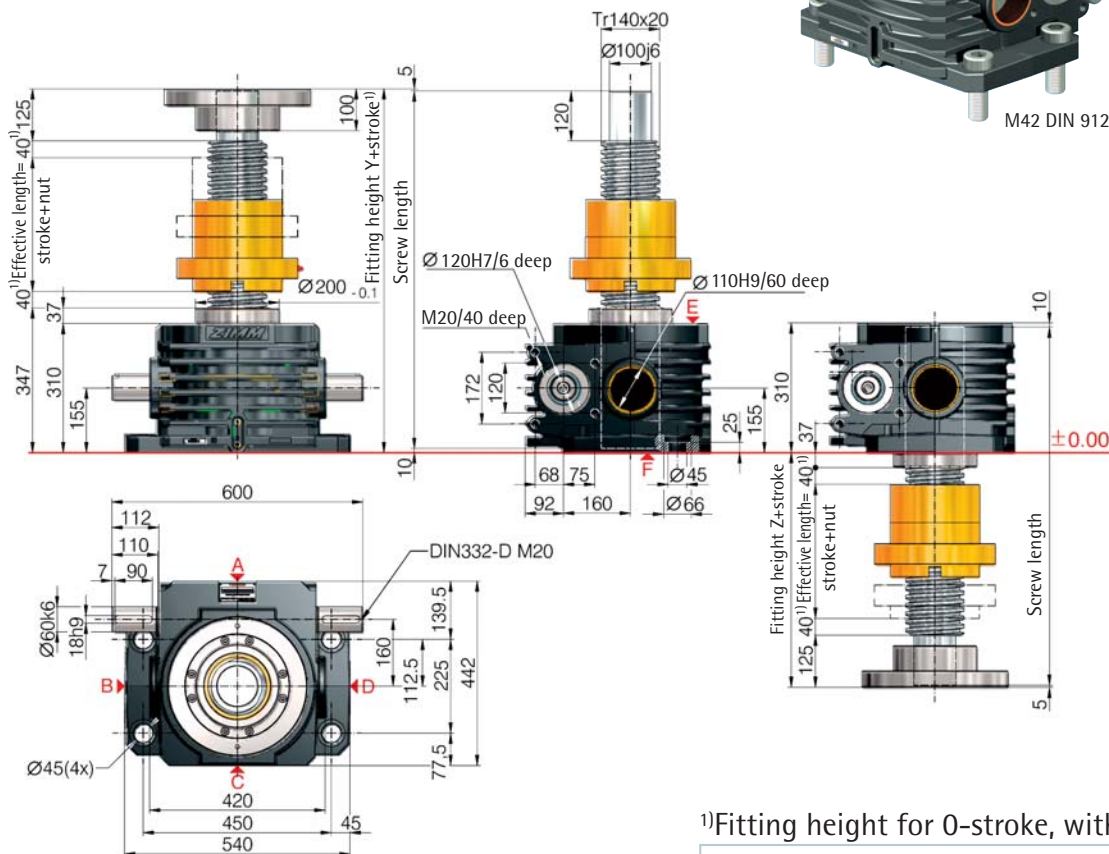

Z-750-R rotating screw 750 kN

Screw
Face EScrew
Face F

M42 DIN 912

1) Fitting height for 0-stroke, with Tr 140x20 screw

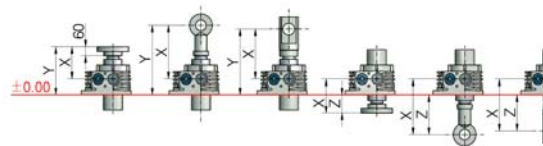

All dimensions in mm	DM	DM with SIFA	DM	DM with SIFA
	Y/A	Y/A	Z/B	Z/B
without bellows FB	772/467	917/612	462/217	607/217

Detailed instructions for determining the length can be found in Section 8

750

kN

Technical data series Z-750-S / Z-750-R

max. compressive/tensile force, static	- 750 kN (75 t)
max. compressive/tensile force, dynamic	- see duty cycle curves
Nominal speed	- 1000 rpm
max. drive shaft speed	- 1000 rpm
Screw size standard	- Tr 140x20 ²⁾
Gear ratio	- 13.33:1 (N) / 40:1 (L)
Housing material	- GGG-50, corrosion-resistant
Worm shaft	- steel, case-hardened, ground
Weight of screw jack body	- 262 kg
Weight of screw/m	- 104 kg
Gearbox lubrication	- synthetic gear oil
Screw lubrication	- grease lubrication
Gearbox operating temperature	- max. 60°C, higher on request
Moment of inertia	- N: 518.1 kg cm ² / L: 256.1 kg cm ²
Input torque (at 1000 rpm)	- max. 480 Nm (N) / max. 210 Nm (L)
Drive-through torque	- max. 4570 Nm

Drive torque M_0 (Nm)	- F (kN) \times 1.22 ³⁾⁵⁾ + M_L (N-normal)
Breakaway torque	- F (kN) \times 0.54 ³⁾⁵⁾ + M_L (L-low speed)
Idling torque ⁴⁾ M_L (Nm)	- Drive torque M_0 \times 1.5
	- 7.28 (N-normal) / 4.42 (L-low speed)

Between gearbox and nut or nut and end of thread, provide for a safety distance of (minimum) 40 mm!

See Section 7 for the checklist.

Important information

- 1) - extension if a bellows or spiral spring is fitted: see Section 8
- 2) - Tr 140x20 is standard, also available: double-pitch, stainless steel, left-handed, increased screw Tr 160x20 (only for the R version)
- 3) - factor includes efficiency, ratio and 30% safety
- 4) - at 20°C, can be higher when new
- 5) - for a 20 mm screw pitch

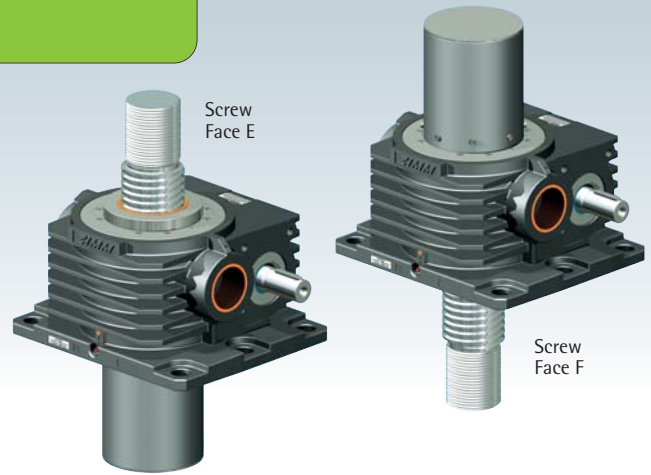

Z-1000-S translating screw 1,000 kN

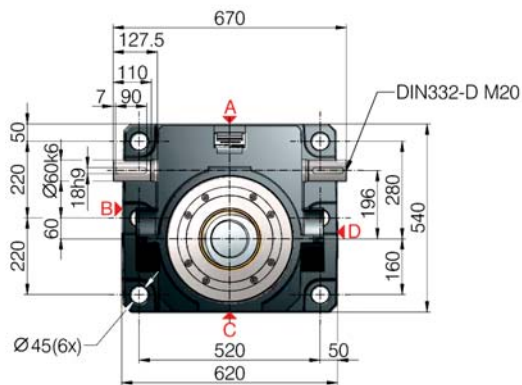
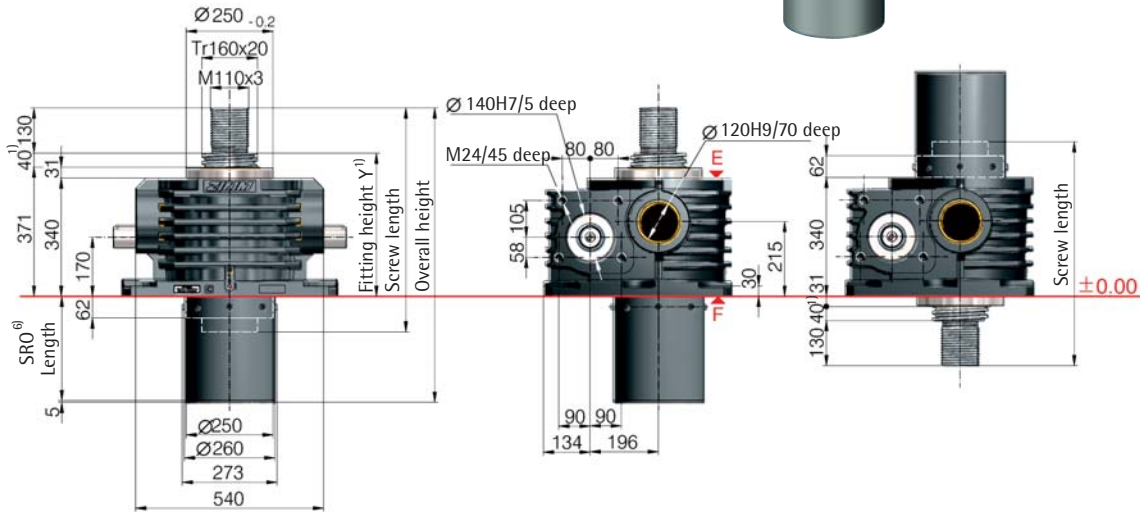

Opening for protective tube SRO

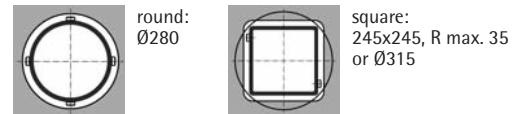

6) Protective tube length SRO with Tr 160x20 screw

only screw	with escape protection AS	with rotation protection VS	with VS and limit switch set ES
○ Ø260	○ Ø260	□ 220x220	□ 220x220
157+stroke	197+stroke	197+stroke	205+stroke

1) Fitting height for 0-stroke, with Tr 160x20 screw

All dimensions in mm	BF		SLK	BF		SLK
	X/Y	X/Y	X/Y	X/Z	X/Z	X/Z
without bellows FB	196/411	328/543	on request	196/181	328/313	on request

Standard ratios

Type	Version	Speed	Standard screw ²⁾	i	Stroke per drive shaft rotation ⁵⁾
Z-1000-SN	Translating screw	Normal	Tr 160x20	13.33:1	1.5 mm
Z-1000-SL		Low speed		40:1	0.5 mm
Z-1000-RN	Rotating screw	Normal	Tr 160x20	13.33:1	1.5 mm
Z-1000-RL		Low speed		40:1	0.5 mm

Screw jack mounting



Duty cycle thermal limit, for S+R

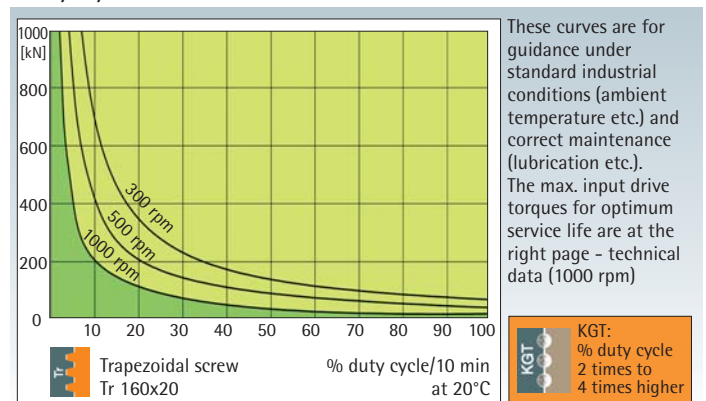

Trapezoidal screw

Tr



Z-1000-R rotating screw 1,000 kN

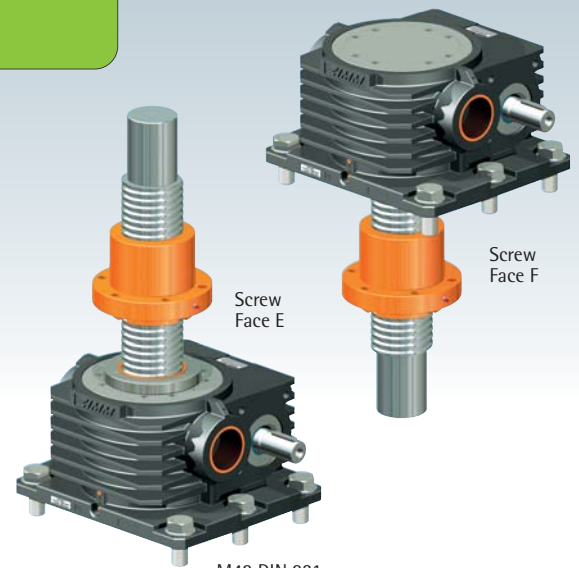
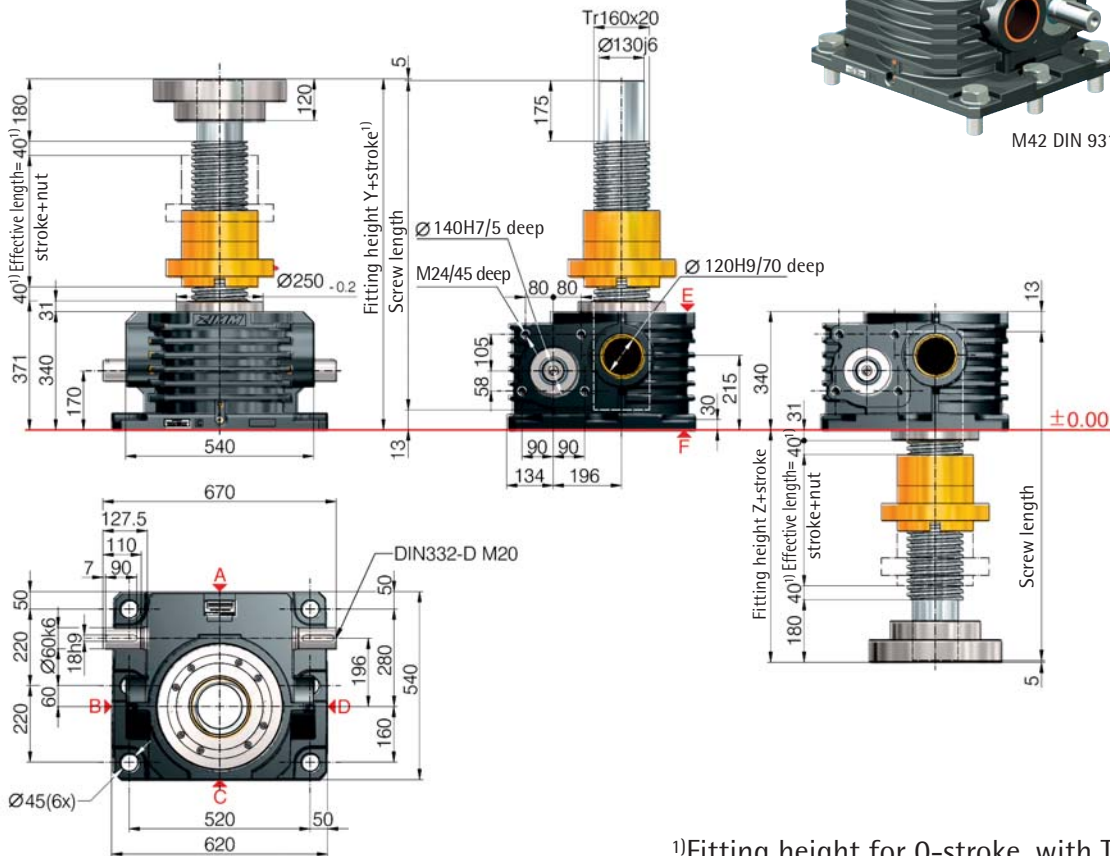

M42 DIN 931

1000

 kN

Technical data series Z-1000-S / Z-1000-R

max. compressive/tensile force, static	- 1000 kN (100 t)
max. compressive/tensile force, dynamic	- see duty cycle curves
Nominal speed	- 1000 rpm
max. drive shaft speed	- 1000 rpm
Screw size standard	- Tr 160x20 ²⁾
Gear ratio	- 13.33:1 (N) / 40:1 (L)
Housing material	- GGG-50, corrosion-resistant
Worm shaft	- steel, case-hardened, ground
Weight of screw jack body	- 408 kg
Weight of screw/m	- 139 kg
Gearbox lubrication	- synthetic gear oil
Screw lubrication	- grease lubrication
Gearbox operating temperature	- max. 60°C, higher on request
Moment of inertia	- N: 1058.2 kg cm ² / L: 459.2 kg cm ²
Input torque (at 1000 rpm)	- max. 680 Nm (N) / max. 450 Nm (L)
Drive-through torque	- max. 4570 Nm

1) Fitting height for 0-stroke, with Tr 160x20 screw

All dimensions in mm	DM		DM with SIFA	
	Y/A	Y/A	Z/B	Z/B
without bellows FB	951/521	1131/701	611/281	791/281

Detailed instructions for determining the length can be found in Section 8

Drive torque M_G (Nm)	- F (kN) \times 1.32 ³⁾⁵⁾ + M_L (N-normal)
Breakaway torque	- F (kN) \times 0.51 ³⁾⁵⁾ + M_L (L-low speed)
Idling torque ⁴⁾ M_L (Nm)	- Drive torque M_G \times 1.5
	- 9.70 (N-normal) / 5.90 (L-low speed)

Between gearbox and nut or nut and end of thread, provide for a safety distance of (minimum) 40 mm!
See Section 7 for the checklist.

Important information

- 1) - extension if a bellows or spiral spring is fitted: see Section 8
- 2) - Tr 160x20 is standard, also available: double-pitch, stainless steel, left-handed, increased screw Tr 190x24 (only for the R version)
- 3) - factor includes efficiency, ratio and 30% safety
- 4) - at 20°C, can be higher when new
- 5) - for a 20 mm screw pitch



Ball screw KGT



Most screw jacks use trapezoidal screws Tr, because they are simple, robust and inexpensive. The proportion of screw jacks that use ball screws is however constantly increasing. The reasons for this are primarily their pitch accuracy, their high efficiency (less power consumption and less heat generation) and the higher pitches available, which permit higher stroke speeds.

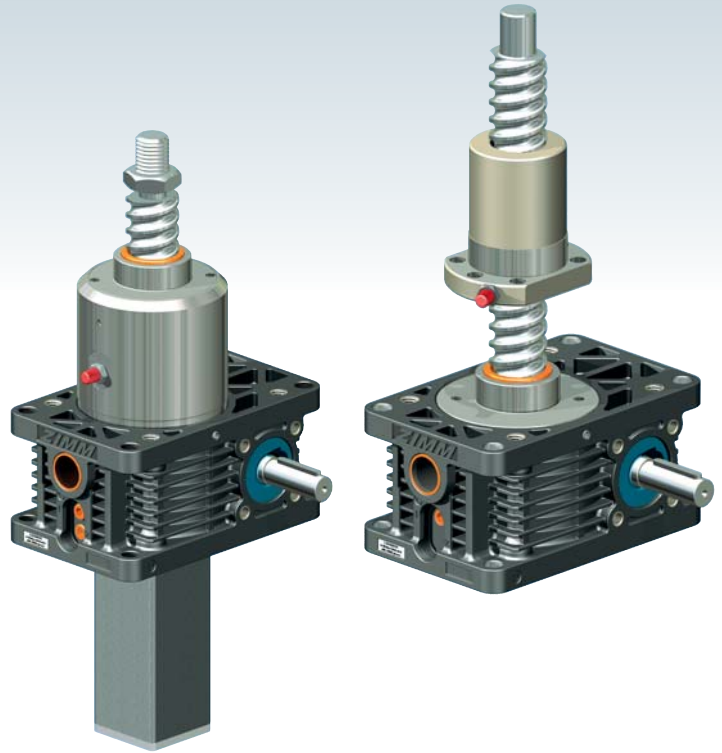

Technical data KGT

Pitch accuracy

0.05 mm / 300 mm

Material: 1.1213 (Cf 53), induction hardened and polished.

No self-locking!

Because of the lack of friction, a holding brake is necessary: a motor brake or a spring pressure brake is required.

Temperatures, duty cycle

Operating temperature range -25°C to + 80°C. The duty cycle can be up to 4 times higher than for trapezoidal screws (see diagrams), and at long strokes up to 2 times higher than for trapezoidal screws.

Service life

Heavy loads reduce the service life of the KGT. Tell us the load and stroke speed and we will calculate the service life.

Contamination

All nuts are fitted with scrapers. For heavy contamination and fine dust/chips, we recommend fitting bellows or a spiral spring cover.

Escape/rotation protection

Under no circumstances may the nut be screwed off the screw. We therefore always provide escape/rotation protection on the S version.

Start ramp / braking ramp

We recommend using a frequency converter or a soft start device, especially for high lead screw jacks. This allows regulation of the start ramp / braking ramp. This ensures protection for the entire system.

Safety clearance L3 can also be reduced at your own discretion, in particular for high pitches.

Grease nipples

The standard position of the grease nipple on the S version is on the gearbox face "C". Optionally, face A is available. Faces B and D are available on request.





UNIQUE:
Ball screw lubrication
for the S version

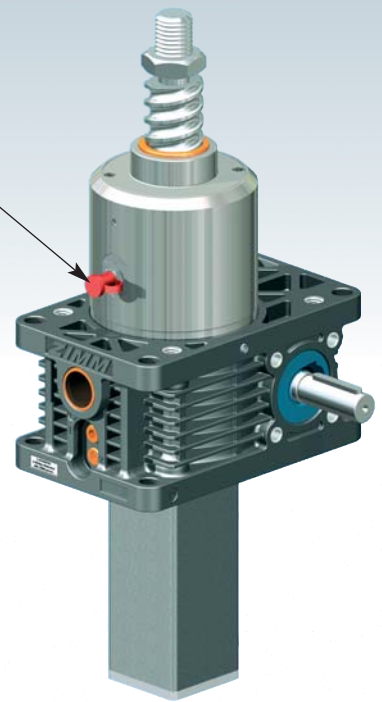

Z-5 to Z-25, KGT-S translating screw

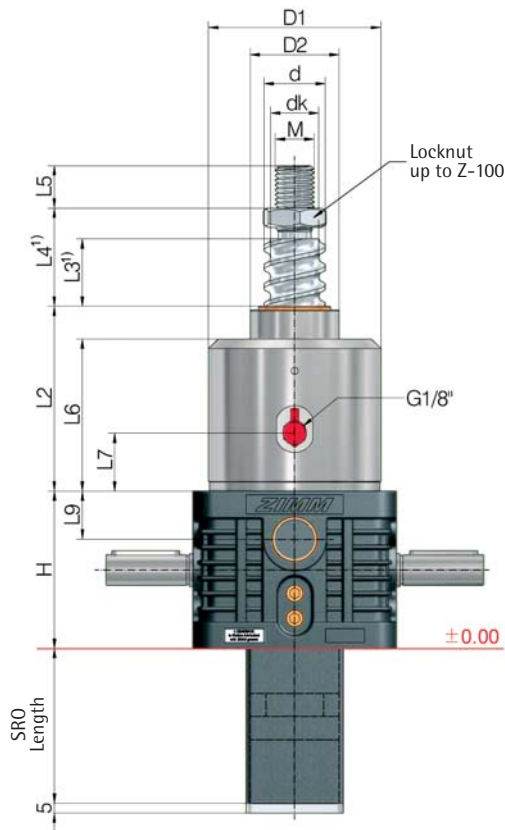

i - further technical information: Page 41
 - see the respective screw jack page for all other dimensions
 - see Section 4 for accessories
 - dimensions on the illustrative diagrams are in mm.
 We reserve the right to make changes.

🛒 **Ordering example:**
 Z-25-SN-KGT 32x10, C = 33.4 kN
 dynamic load rating C

Screw jacks	Ball screw KGT ØxP	Stroke per drive revolution [mm]		KGT load rating [kN]		Dimensions [mm]													Axial play max ⁵⁾ [mm]
		SN	SL	dyn. C ²⁾	stat. C ₀ =C _{0a}	H	d	d _k	D ₁	D ₂	L ₂	L ₃ ¹⁾	L ₄ ¹⁾	L ₅	L ₆	L ₇	L ₉	M	
Z-5	16x5	1.25	0.31	9.3	13.1	62	15.5	12.9	59	29	66	15	25	19	54	23	18	M12	0.08
	16x10	2.50	0.63	15.4	26.5	62	15.4	13.0	59	29	66	25	35	19	54	23	18	M12	0.08
Z-10	25x5	1.25	0.31	12.3	22.5	74	24.5	21.9	69	39	85	15	27	20	69	21	21	M14	0.08
	25x10	2.50	0.63	13.2	25.3	74	24.5	21.9	69	39	85	25	37	20	69	21	21	M14	0.08
	25x25	6.25	1.56	16.7	32.2	74	24.5	22.0	69	39	85	60	72	20	69	21	21	M14	0.08
	25x50	12.50	3.13	15.4	31.7	74	24.1	21.5	69	39	85	125	137	20	69	21	21	M14	0.15
Z-25	32x5	0.83	0.21	21.5	49.3	82	31.5	28.9	89	46	99	15	31	22	82	33	25	M20	0.08
	32x10	1.67	0.42	33.4	54.5	82	32.7	27.3	89	46	99	20	36	22	82	33	25	M20	0.08
	32x20	3.33	0.83	29.7	59.8	82	31.7	27.9	89	46	99	35	51	22	82	33	25	M20	0.08
	32x40	6.67	1.67	14.9	32.4	82	30.9	28.3	89	46	99	70	86	22	82	33	25	M20	0.08

¹⁾ Depending on the control system and drive, the dimensions L₃ and L₄ can be reduced at your own discretion, in particular for high pitches. An extension may be required if a bellows or spiral spring extension is fitted
²⁾ Dynamic load rating to DIN 69051 part 4 draft 1989

⁵⁾ Reduced play 0.02 mm available on request



Z-5 to Z-25, KGT-R rotating screw

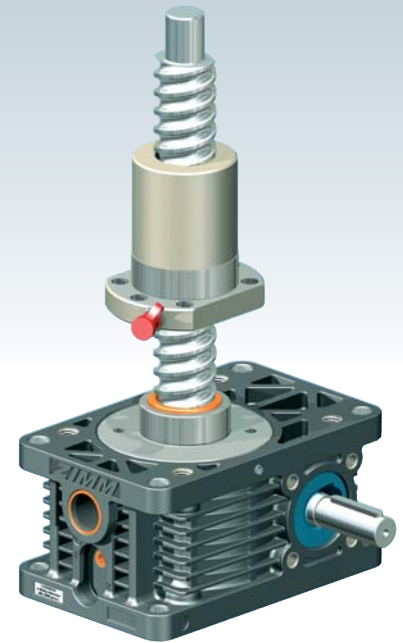

2

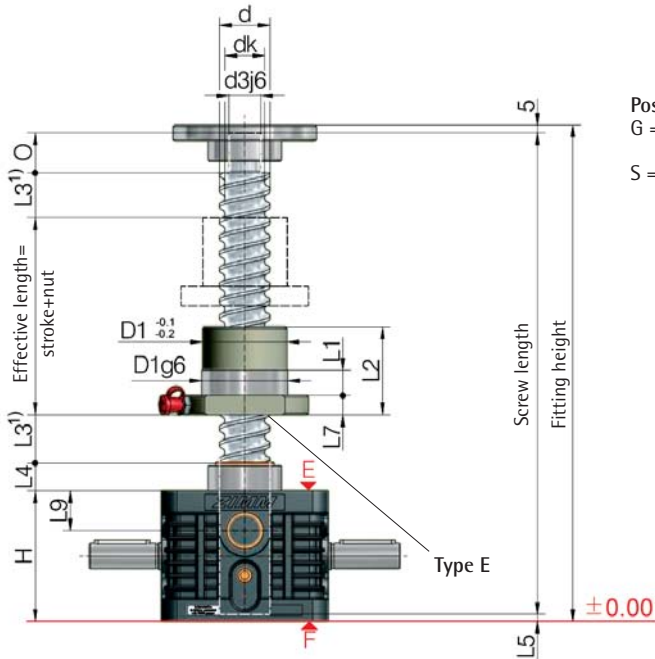

Position of the flanged nut:
G = flange gearbox side (as shown)
S = flange screw side

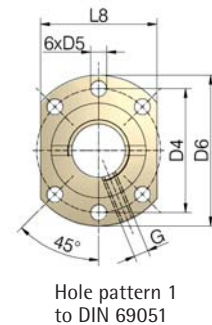
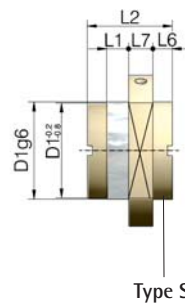

Hole pattern 1 to DIN 69051

i Adapter for KGT
Dimension sheet on request (up to KGT Ø50)

i - further technical information: Page 41
- see the respective screw jack page for all other dimensions
- see Section 4 for accessories
- dimensions on the illustrative diagrams are in mm.
We reserve the right to make changes.

Shopping cart icon **Ordering example:**
Z-25-RN-KGT 32x10, C = 33.4 kN - G
dynamic load rating C
Nut flange
G: flange gearbox side
S: flange screw side

Screw jacks	Ball screw KGT	Stroke per drive revolution [mm]		KGT load rating [kN]		Nut Type	Hole pattern	Dimensions [mm]																Lubrication hole	Axial play max ⁵⁾ [mm]		
		RN	RL	dyn. C ²⁾	stat. C ₀ =C _{0a}			d	dk	d ₃	O	H	D ₁	D ₄	D ₅	D ₆	L ₁	L ₂	L ₃ ¹⁾	L ₄	L ₅	L ₆	L ₇			L ₈	L ₉
Z-5	16x5	1.25	0.31	9.3	13.1	E	1	15.5	12.9	12	15	62	28	38	5.5	48	10	42	15	12	8	-	10	40	18	M6	0.08
	16x10	2.50	0.63	15.4	26.5	E	1	15.4	13.0	12	15	62	28	38	5.5	48	10	55	25	12	8	-	10	40	18	M6	0.08
Z-10	25x5	1.25	0.31	12.3	22.5	E	1	24.5	21.9	15	20	74	40	51	6.6	62	10	42	15	16	8	-	10	48	21	M6	0.08
	25x10	2.50	0.63	13.2	25.3	E	1	24.5	21.9	15	20	74	40	51	6.6	62	16	55	25	16	8	-	10	48	21	M6	0.08
	25x25 ³⁾	6.25	1.56	16.7	32.2	S	1	24.5	22.0	15	20	74	40	51	6.6	62	9	35	60	16	8	8	10	- ³⁾	21	M6	0.08
Z-25	25x50	12.50	3.14	15.4	31.7	S	1	24.1	21.5	15	20	74	40	51	6.6	62	10	58	125	16	8	10	10	48	21	M6	0.15
	32x5	0.83	0.21	21.5	49.3	E	1	31.5	28.9	20	25	82	50	65	9.0	80	10	55	15	17	5	-	12	62	25	M6	0.08
	32x10	1.67	0.42	33.4	54.5	E	1	32.7	27.3	20	25	82	53 ⁶⁾	65	9.0	80	16	69	20	17	5	-	12	62	25	M8x1	0.08
	32x20	3.33	0.83	29.7	59.8	E	1	31.7	27.9	20	25	82	53 ⁶⁾	65	9.0	80	16	80	35	17	5	-	12	62	25	M6	0.08
	32x40 ³⁾	6.67	1.67	14.9	32.4	S	N ⁴⁾	30.9	28.3	20	25	82	53 ⁶⁾	68 ⁶⁾	7.0 ⁶⁾	80	14	45	70	17	5	7.5	16	- ³⁾	25	M6	0.08

An increased screw (such as: Z-10-RN with screw 32x10) can also be used for the rotating version.

¹⁾ An extension may be required if a bellows or spiral spring is fitted
²⁾ Dynamic load rating to DIN 69051 part 4 draft 1989
³⁾ Round flange
⁴⁾ Hole pattern on request
⁵⁾ Reduced play 0.02 mm available on request

⁶⁾ Not to DIN 69051



UNIQUE:
Ball screw lubrication
for the S version

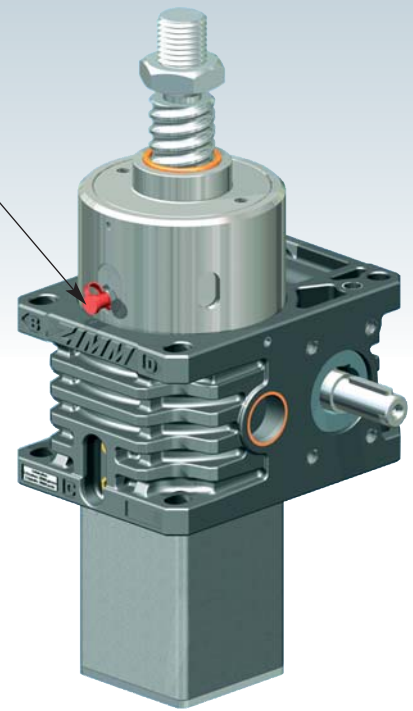

Z-50 to Z-150, KGT-S translating screw

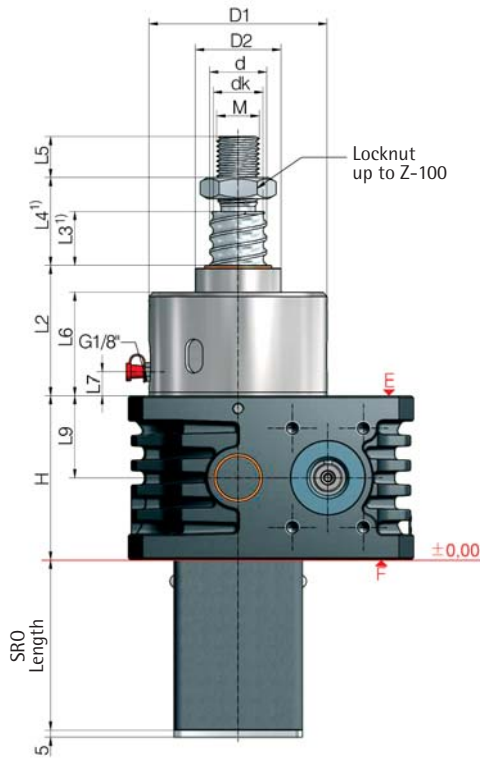

i - further technical information: Page 41
 - see the respective screw jack page for all other dimensions
 - see Section 4 for accessories
 - dimensions on the illustrative diagrams are in mm.
 We reserve the right to make changes.

Shopping cart icon **Ordering example:**
 Z-100-SN-KGT 50x20, C = 112.4 kN
 dynamic load rating C

Screw jacks	Ball screw KGT	Stroke per drive revolution [mm]		KGT load rating [kN]		Dimensions [mm]													Axial play max ⁵⁾ [mm]
		SN	SL	dyn. C ²⁾	stat. C ₀ =C _{0a}	H	d	dk	D ₁	D ₂	L ₂	L ₃ ¹⁾	L ₄ ¹⁾	L ₅	L ₆	L ₇	L ₉	M	
Z-50	40x5	0.71	0.18	23.8	63.1	116	39.5	36.9	125	60	93	15	39	29	74	17	58	M30	0.08
	40x10	1.43	0.36	38	69.1	116	39.5	34.1	125	60	93	15	39	29	74	17	58	M30	0.08
	40x20	2.86	0.72	33.3	76.1	116	39.7	35.9	125	60	93	30	54	29	74	17	58	M30	0.08
	40x40	5.71	1.43	35	101.9	116	38.9	36.3	125	60	93	60	84	29	74	17	58	M30	0.08
Z-100	50x10	1.11	0.28	68.7	155.8	160	49.5	44.1	148	85	112	20	48	48	82	19	80	M36	0.08
	50x20	2.22	0.56	60	136.3	160	49.5	44.1	148	85	112	40	68	48	82	19	80	M36	0.08
	50x10	1.11	0.28	112.1	338.5	160	50	43.6	148	85	148	20	48	48	118	19	80	M36	0.03
	50x20	2.22	0.56	112.4	214.7	160	50	41.1	148	85	148	40	68	48	118	19	80	M36	0.03
	50x40	4.44	1.11	84.7	143.1	160	50	41.1	148	85	148	80	108	48	118	19	80	M36	0.03
Z-150	63x10 ³⁾	1.11	0.28	76	197	185	62.5	57.1	168	90	122	20	20	48	90	17	92.5	M42x2	0.08
	63x20 ³⁾	2.22	0.56	105	250	185	63	55.4	168	90	156	40	40	48	124	45	92.5	M42x2	0.05
	63x10	1.11	0.28	150.2	598.4	185	63	56.6	168	90	150	20	20	48	118	24	92.5	M42x2	0.03
	63x20	2.22	0.56	173.5 ⁷⁾	346.2	185	63	51.8	168	90	150	40	40	48	118	24	92.5	M42x2	0.03
	63x40	4.44	1.11	96.6	205.1	185	63	54.1	168	90	150	80	80	48	118	24	92.5	M42x2	0.03
	63x60 ⁴⁾	6.67	1.67	59.5	102.5	185	63	54.1	168	90	150	120	120	48	118	24	92.5	M42x2	0.03

¹⁾ Depending on the control system and drive, the dimensions L₃ and L₄ can be reduced at your own discretion, in particular for high pitches. An extension may be required if a bellows or spiral spring is fitted

²⁾ Dynamic load rating to DIN 69051 part 4 draft 1989

⁴⁾ Non-preferred design

⁵⁾ Reduced play 0.02 mm available on request

⁷⁾ Service life calculation with C_{dyn} 159 kN (gearbox bearing)

⁸⁾ Design being superseded



Z-35 to Z-150, KGT-R rotating ball screw

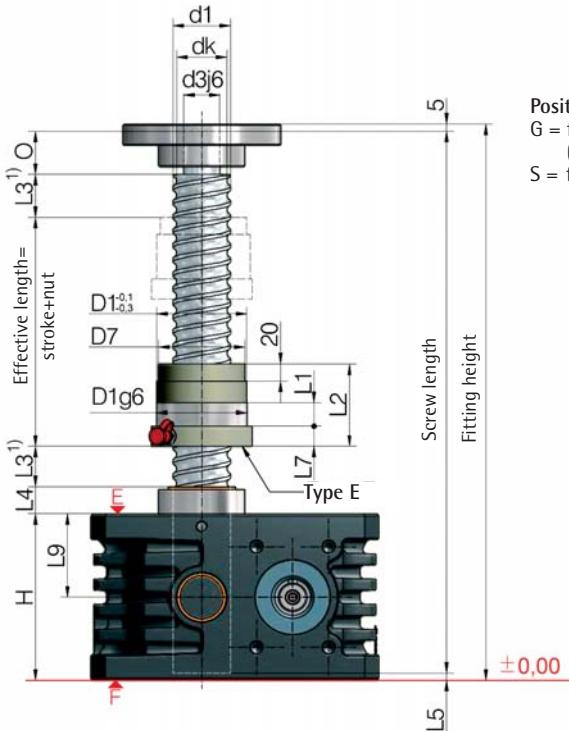

Position of the flanged nut:
G = flange gearbox side (as shown)
S = flange screw side

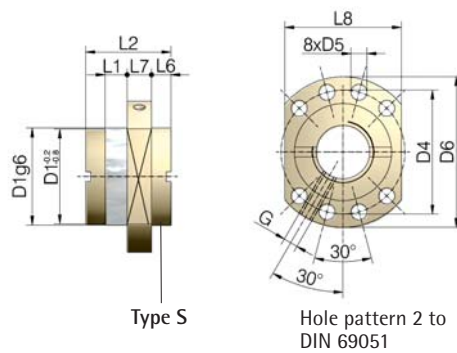
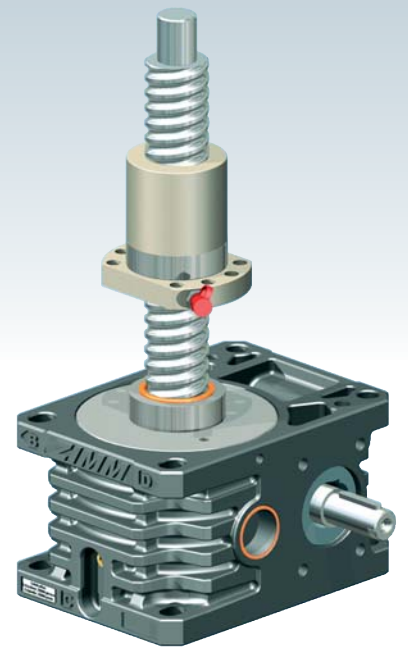

Adapter for KGT
Dimension sheet on request (up to KGT Ø50)

- further technical information: Page 41
- see the respective screw jack page for all other dimensions
- see Section 4 for accessories
- dimensions on the illustrative diagrams are in mm. We reserve the right to make changes.

Ordering example:
Z-100-RN-KGT 50x20, C = 112.4 kN - G
dynamic load rating C
Nut flange
G: flange gearbox side
S: flange screw side

Screw jacks	Ball screw KGT ØxP	Stroke per drive revolution [mm]		KGT load rating [kN]		Nut Type	Hole pattern	Dimensions [mm]																			Lubrication hole G	Axial play max ⁵⁾ [mm]
		RN	RL	dyn. C ²⁾	stat. C ₀ =C _{0a}			d	d _k	d ₃	O	H	D ₁	D ₄	D ₅	D ₆	D ₇	L ₁	L ₂	L ₃ ¹⁾	L ₄	L ₅	L ₆	L ₇	L ₈	L ₉		
Z-35	40x5	0.71	0.18	23.8	63.1	E 2	2	39.5	36.9	25	30	100	63	78	9	93	-	10	57	15	19	7	-	14	70	50 ⁷⁾	M6	0.08
	40x10	1.43	0.36	38	69.1	E 2	2	39.5	34.1	25	30	100	63	78	9	93	-	16	71	15	19	7	-	14	70	50 ⁷⁾	M8x1	0.08
	40x20	2.86	0.72	33.3	76.1	E 2	2	39.7	35.9	25	30	100	63	78	9	93	-	16	80	30	19	7	-	14	70	50 ⁷⁾	M8x1	0.08
	40x40	5.71	1.43	35	101.9	S 2	2	38.9	36.3	25	30	100	63	78	9	93	-	16	85	60	19	7	7.5	14	- ³⁾	50 ⁷⁾	M8x1	0.08
Z-50	40x5	0.71	0.18	23.8	63.1	E 2	2	39.5	36.9	25	30	116	63	78	9	93	-	10	57	15	19	7	-	14	70	58 ⁷⁾	M6	0.08
	40x10	1.43	0.36	38	69.1	E 2	2	39.5	34.1	25	30	116	63	78	9	93	-	16	71	15	19	7	-	14	70	58 ⁷⁾	M8x1	0.08
	40x20	2.86	0.72	33.3	76.1	E 2	2	39.7	35.9	25	30	116	63	78	9	93	-	16	80	30	19	7	-	14	70	58 ⁷⁾	M8x1	0.08
	40x40	5.71	1.43	35	101.9	S 2	2	38.9	36.3	25	30	116	63	78	9	93	-	16	85	60	19	7	7.5	14	- ³⁾	58 ⁷⁾	M8x1	0.08
Z-100	50x10	1.11	0.28	68.7	155.8	E 2	2	49.5	44.1	40	45	160	75	93	11	110	-	16	95	20	30	8	-	16	85	80	M8x1	0.08
	50x20	2.22	0.56	60	136.3	E 2	2	49.5	44.1	40	45	160	85 ⁶⁾	103 ⁶⁾	11	125 ⁶⁾	-	22	95	40	30	8	-	18	95	80	M8x1	0.08
	50x10	1.11	0.28	112.1	338.5	E 2	2	50	43.6	40	45	160	75	93	11	110	-	16	107	20	30	8	-	16	85	80	M8x1	0.03
	50x20	2.22	0.56	112.4	214.7	E 2	2	50	41.1	40	45	160	85 ⁶⁾	103 ⁶⁾	11	120 ⁶⁾	-	16	125	40	30	8	-	16	95	80	M8x1	0.03
	50x40	4.44	1.11	84.7	143.1	E 2	2	50	41.1	40	45	160	85 ⁶⁾	103 ⁶⁾	11	120 ⁶⁾	-	16	125	80	30	8	-	16	95	80	M8x1	0.03
Z-150	50x50 ⁴⁾	5.56	1.39	84.7	143.1	E 2	2	50	41.1	40	45	160	85 ⁶⁾	103 ⁶⁾	11	120 ⁶⁾	-	16	145	100	30	8	-	16	95	80	M8x1	0.03
	63x10 ⁸⁾	1.11	0.28	84.7	210.8	E 2	2	63	58.8	45	55	185	90	108	11	125	-	16	120	20	32	7	-	18	95	92.5 ⁷⁾	M8x1	0.05
	63x20 ⁸⁾	2.22	0.56	230 ⁷⁾	600	E 2	2	60	50.2	45	55	185	125 ⁶⁾	145 ⁶⁾	13.5	165 ⁶⁾	-	25	170	40	32	7	-	25	130	92.5 ⁷⁾	M8x1	0.05
	63x10	1.11	0.28	150.2	598.4	E 2	2	63	56.6	45	55	185	90	108	11	125	-	16	135	20	32	7	-	18	95	92.5 ⁷⁾	M8x1	0.03
	63x20	2.22	0.56	173.5 ⁷⁾	346.2	E 2	2	63	51.8	45	55	185	95	115	13.5	135	90	25	135	40	32	7	-	20	100	92.5 ⁷⁾	M8x1	0.03
	63x40	4.44	1.11	96.6	205.1	E 2	2	63	54.1	45	55	185	95	115	13.5	135	90	25	126	80	32	7	-	20	100	92.5 ⁷⁾	M8x1	0.03
63x60 ⁴⁾	6.67	1.67	59.5	102.5	E 2	2	63	54.1	45	55	185	95	115	13.5	135	90	25	126	120	32	7	-	20	100	92.5 ⁷⁾	M8x1	0.03	

¹⁾ An extension may be required if a bellows or spiral spring is fitted
²⁾ Dynamic load rating to DIN 69051 part 4 draft 1989
³⁾ Round flange
⁴⁾ Non-preferred design

⁵⁾ Reduced play 0.02 mm available on request
⁶⁾ Not to DIN 69051
⁷⁾ Service life calculation with C_{dyn} 159 kN (gearbox bearing)
⁸⁾ Design being superseded



UNIQUE:
Ball screw lubrication
for the S version

Z-250 and Z-350, KGT-S
Translating screw

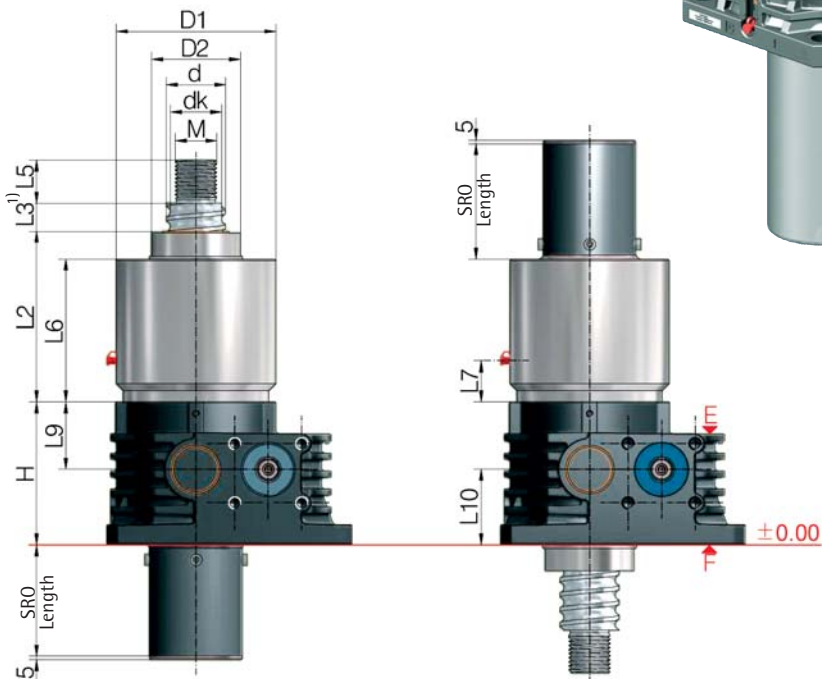
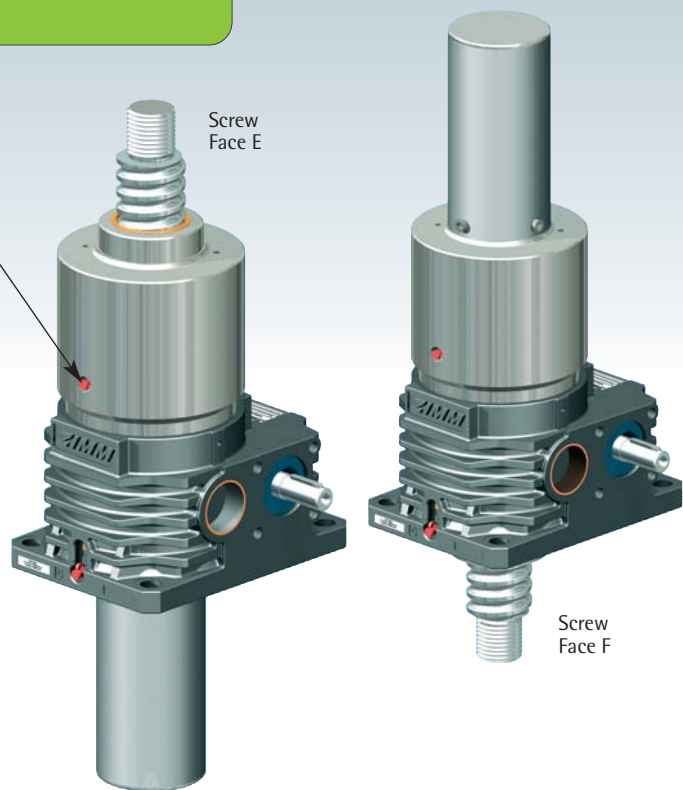

i - further technical information: Page 41
 - see the respective screw jack page for all other dimensions
 - see Section 4 for accessories
 - dimensions on the illustrative diagrams are in mm.
 We reserve the right to make changes.

Shopping cart icon **Ordering example:**
Z-250-SN-E-KGT 80x40, C = 251.2 kN
 Screw face E or F
 dynamic load rating C

Screw jacks	Ball screw KGT	Stroke per drive revolution [mm]		KGT load rating [kN]		Dimensions [mm]													Axial play max. [mm]
		SN	SL	dyn. C ²⁾	stat. C ₀ =C _{0a}	H	d	d _k	D ₁	D ₂	L ₂	L ₃ ¹⁾	L ₅	L ₆	L ₇	L ₉	L ₁₀	M	
Z-250	80x10 ⁴⁾	0.94	0.31	193.0	993.4	193	80	73.6	216	120	228	20	58	191	45	91	102	M56x2	0.03
	80x20	1.87	0.63	359.2	942.5	193	80	67	216	120	228	40	58	191	45	91	102	M56x2	0.03
	80x40	3.75	1.25	251.2	565.5	193	80	67	216	120	228	80	58	191	45	91	102	M56x2	0.03
	80x60	5.62	1.88	189.1	377.0	193	80	67	216	120	228	120	58	191	45	91	102	M56x2	0.03
Z-350	100x20	1.87	0.63	330.2	979.1	230	100	87.4	275	145	223	40	78	199	54	115	115	M72x3	0.03
	100x40	3.75	1.25	270.0	734.0	230	100	87.4	275	145	223	80	78	199	54	115	115	M72x3	0.03
	100x60	5.62	1.88	203.0	489.6	230	100	87.4	275	145	223	120	78	199	54	115	115	M72x3	0.03
	100x80 ⁴⁾	7.50	2.50	203.0	489.6	230	100	87.4	275	145	263	160	78	239	54	115	115	M72x3	0.03

¹⁾ Depending on the control system and drive, the dimension L₃ can be reduced at your own discretion. An extension may be required if a bellows or spiral spring is fitted

²⁾ Dynamic load rating to DIN 69051 part 4 draft 1989

⁴⁾ Non-preferred design



Z-250 and Z-350, KGT-R
Rotating screw

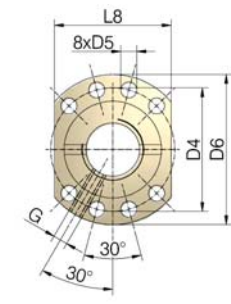
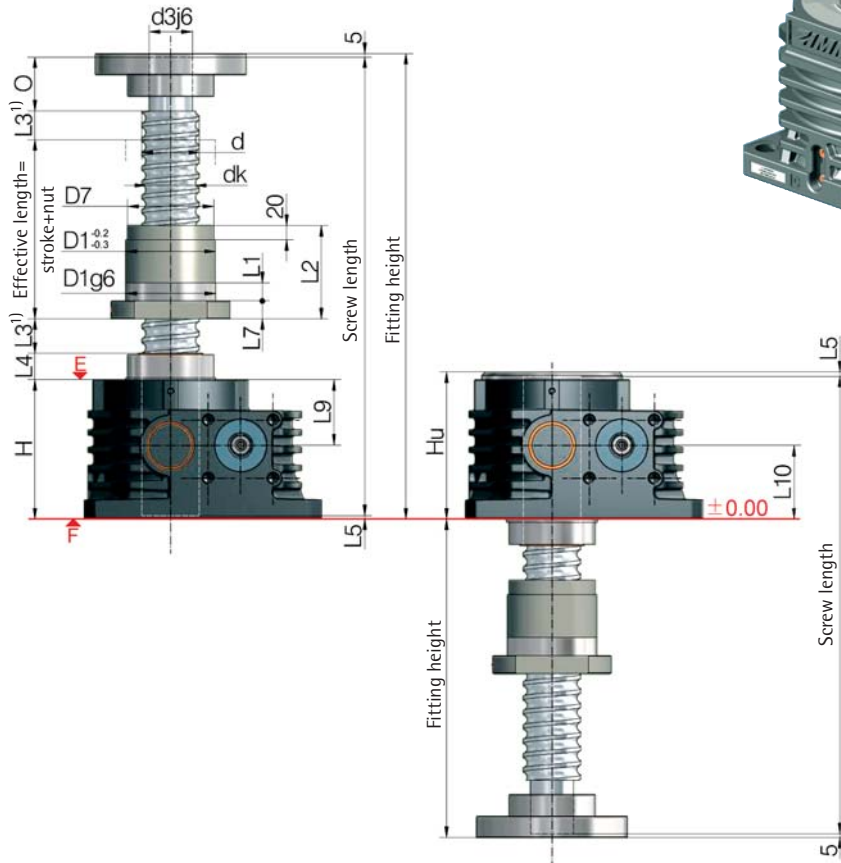

Hole pattern 2 to DIN 69051

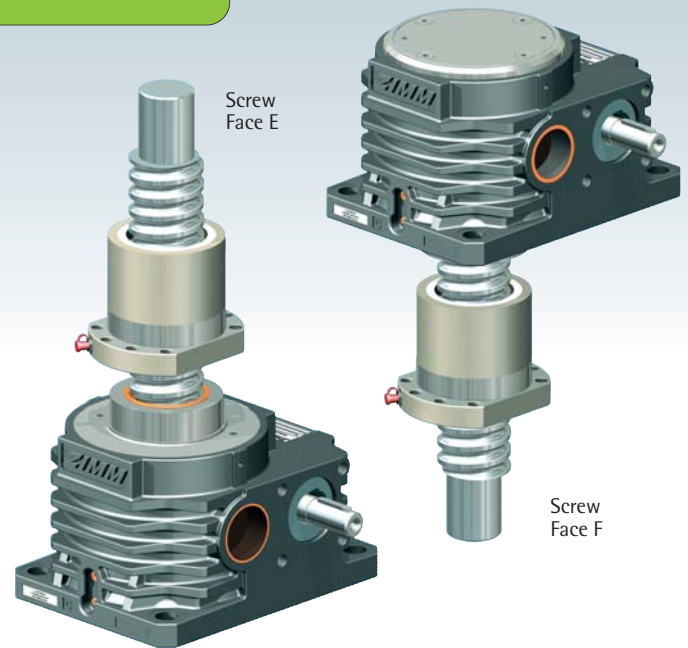

i - further technical information: Page 41
 - see the respective screw jack page for all other dimensions
 - see Section 4 for accessories
 - dimensions on the illustrative diagrams are in mm.
 We reserve the right to make changes.

Ordering example:
Z-250-RN-E-KGT 80x40, C = 112.4 kN - G
 Screw face E or F
 dynamic load rating C
 Nut flange
 G: flange gearbox side
 S: flange screw side

Screw jacks	Ball screw KGT	Stroke per drive revolution [mm]		KGT load rating [kN]		Nut Type	Nut Hole pattern	Dimensions [mm]														Lubri-cation hole G	Axial play max [mm]						
		RN	RL	dyn. C ²⁾	stat. C ₀ =C _{0a}			d	dk	ds	O	H	H _u	D ₁	D ₂	D ₅	D ₆	D ₇	L ₁	L ₂	L ₃			L ₄	L ₅	L ₇	L ₈	L ₉	L ₁₀
Z-250	80x10 ⁴⁾	0.94	0.31	93.4	269.2	E 2	2	80	75.8	60	75	193	204	105	125	13.5	145	-	16	120	20	37	5	20	110	91	102	M8x1	0.05
	80x20 ⁴⁾	1.87	0.63	320.0	820.0	E 2	2	78	68.2	60	75	193	204	135	155	13.5	175	-	25	190	40	37	5	25	140	91	102	M8x1	0.05
	80x10 ⁴⁾	0.94	0.31	193.0	993.4	E 2	2	80	73.6	60	75	193	204	105	125	13.5	145	-	16	160	20	37	5	20	110	91	102	M8x1	0.03
	80x20	1.87	0.63	359.2	942.5	E 2	2	80	67	60	75	193	204	125	145	13.5	165	120	25	190	40	37	5	25	130	91	102	M8x1	0.03
	80x40	3.75	1.25	251.2	565.5	E 2	2	80	67	60	75	193	204	125	145	13.5	165	120	25	190	80	37	5	25	130	91	102	M8x1	0.03
Z-350	80x60	5.62	1.88	189.1	377.0	E 2	2	80	67	60	75	193	204	125	145	13.5	165	120	25	190	120	37	5	25	130	91	102	M8x1	0.03
	100x20	1.87	0.63	330.2	979.1	E 2	2	100	87.4	80	100	230	230	150	176	17.5	202	145	25	175	40	24	6	30	155	115	115	M8x1	0.03
	100x40	3.75	1.25	270.0	734.0	E 2	2	100	87.4	80	100	230	230	150	176	17.5	202	145	25	175	80	24	6	30	155	115	115	M8x1	0.03
	100x60	5.62	1.88	203.0	489.6	E 2	2	100	87.4	80	100	230	230	150	176	17.5	202	145	25	175	120	24	6	30	155	115	115	M8x1	0.03
	100x80	7.50	2.50	203.0	489.6	E 2	2	100	87.4	80	100	230	230	150	176	17.5	202	145	25	215	160	24	6	30	155	115	115	M8x1	0.03

¹⁾ An extension may be required if a bellows or spiral spring is fitted
²⁾ Dynamic load rating to DIN 69051 part 4 draft 1989

⁴⁾ Non-preferred design



UNIQUE:
Ball screw lubrication for
the S version

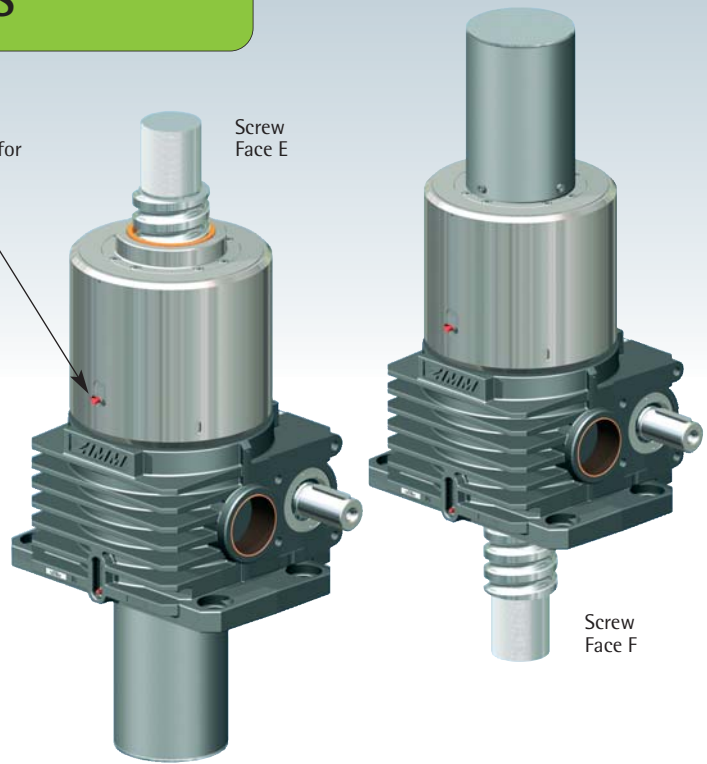

Z-500 to Z-1000, KGT-S
Translating screw

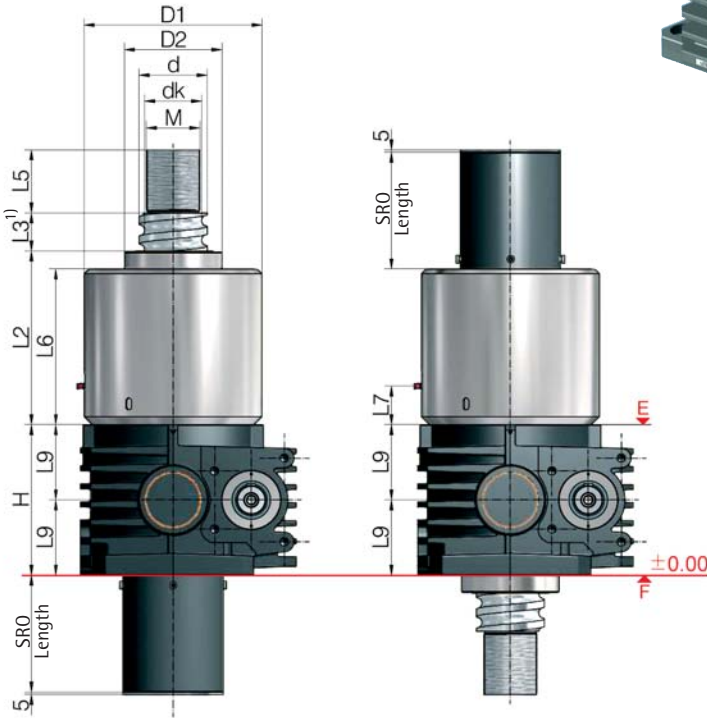

- further technical information: Page 41
- see the respective screw jack page for all other dimensions
- see Section 4 for accessories
- dimensions on the illustrative diagrams are in mm.
- We reserve the right to make changes.

Ordering example:

Z-1000-SN-E-KGT 160x40, C = 1069.9 kN

Screw face E or F

dynamic load rating C

Screw jacks	Ball screw KGT	Stroke per drive revolution [mm]		KGT load rating [kN]		Dimensions [mm]											Axial play max. [mm]	
		SN	SL	dyn. C ²⁾	stat. C ₀ =C _{0a}	H	d	dk	D ₁	D ₂	L ₂	L ₃ ¹⁾	L ₅	L ₆	L ₇	L ₉		M
Z-500	125x25	2.34	0.78	575.1	1863	260	125	107.8	315	170	283	50	118	251	55	130	M100x3	0.03
	125x40	3.75	1.25	402.2	1117	260	125	107.8	315	170	283	80	118	251	55	130	M100x3	0.03
	125x60	5.62	1.88	302.8	745.3	260	125	107.8	315	170	283	120	118	251	55	130	M100x3	0.03
	125x80	7.50	2.50	218.7	630.5	260	125	112.4	315	170	283	160	118	251	55	130	M100x3	0.03
Z-750	140x25	1.88	0.63	774.3	3082	310	140	122.8	365	200	374	50	130	337	84	155	M110x3	0.03
	140x40	3.00	1.00	754.0	2100	310	140	117	365	200	374	80	130	337	84	155	M110x3	0.03
	140x60	4.50	1.50	616.7	1575	310	140	117	365	200	374	120	130	337	84	155	M110x3	0.03
	140x80	6.00	2.00	464.3	1048	310	140	117	365	200	374	160	130	337	84	155	M110x3	0.03
Z-1000	160x25	1.88	0.63	884.7	4068	340	160	142.8	405	250	392	50	130	360	79	170	M110x3	0.03
	160x40	3.00	1.00	1069.9	3016	340	160	132.8	405	250	392	80	130	360	79	170	M110x3	0.03
	160x60	4.50	1.50	663.0	1923	340	160	137	405	250	392	120	130	360	79	170	M110x3	0.03
	160x80	6.00	2.00	499.1	1282	340	160	137	405	250	392	160	130	360	79	170	M110x3	0.03

¹⁾ Depending on the control system and drive, the dimension L₃ can be reduced at your own discretion. An extension may be required if a bellows or spiral spring is fitted

²⁾ Dynamic load rating to DIN 69051 part 4 draft 1989



Z-500 to Z-1000, KGT-R
Rotating screw

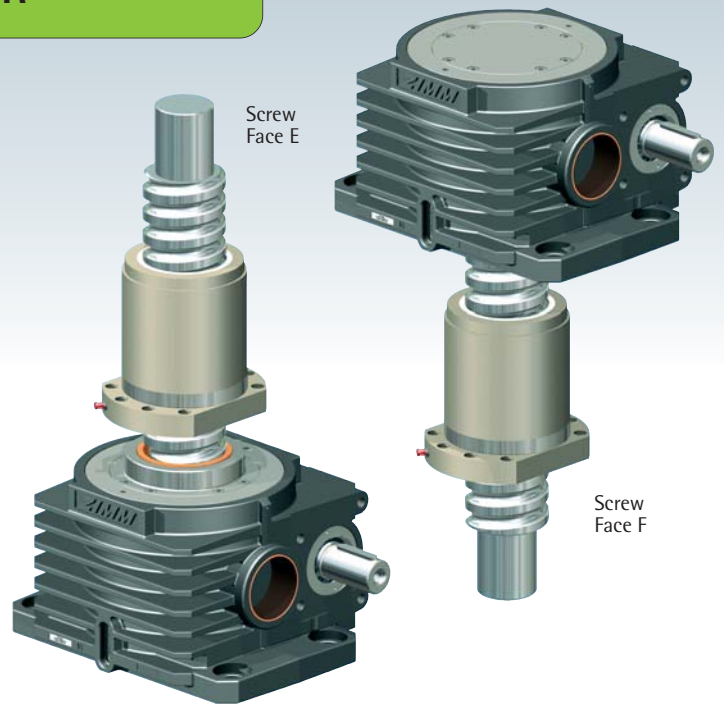
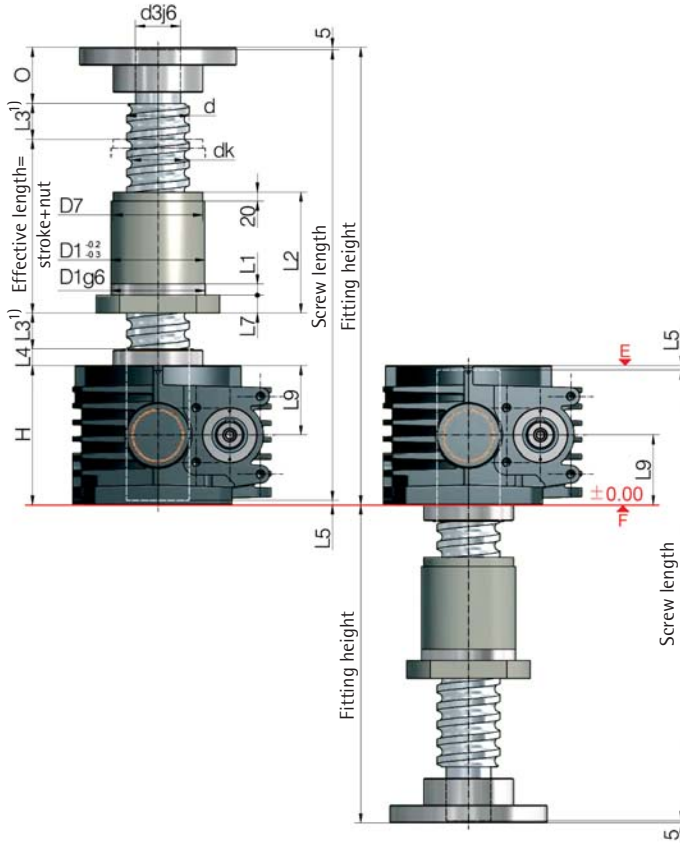

Screw Face E

Screw Face F

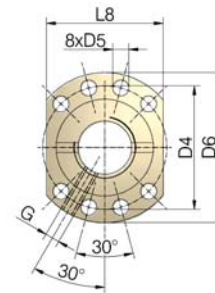

Hole pattern 2 to DIN 69051

- further technical information: Page 41
 - see the respective screw jack page for all other dimensions
 - see Section 4 for accessories
 - dimensions on the illustrative diagrams are in mm.
- We reserve the right to make changes

Ordering example:
Z-1000-RN-E-KGT 160x40, C = 1069.9 kN - G
 Screw face E or F
 dynamic load rating C
 Nut flange
 G: flange gearbox side
 S: flange screw side

Screw jacks	Ball screw KGT	Stroke per drive revolution [mm]		KGT load rating [kN]		Nut Type	Hole pattern	Dimensions [mm]																	Lubri-cation hole	Axial play max [mm]	
		RN	RL	dyn. C ²⁾	stat. C ₀ =C _{0a}			d	d _k	d ₃	O	H	D ₁	D ₄	D ₅	D ₆	D ₇	L ₁	L ₂	L ₃ ¹⁾	L ₄	L ₅	L ₇	L ₈			L ₉
Z-500	125x25	2.34	0.78	575.1	1863	E 2	2	125	107.8	95	120	260	185	212	17.5	240	170	25	250	50	32	6	30	190	130	M8x1	0.03
	125x40	3.75	1.25	402.2	1117	E 2	2	125	107.8	95	120	260	185	212	17.5	240	170	25	250	80	32	6	30	190	130	M8x1	0.03
	125x60	5.62	1.88	302.8	745.3	E 2	2	125	107.8	95	120	260	185	212	17.5	240	170	25	180	120	32	6	30	190	130	M8x1	0.03
	125x80	7.50	2.50	218.7	630.5	E 2	2	125	112.4	95	120	260	185	212	17.5	240	170	25	220	160	32	6	30	190	130	M8x1	0.03
Z-750	140x25	1.88	0.63	774.3	3082	E 2	2	140	122.8	100	120	310	210	243	22	275	200	25	310	50	37	10	40	215	115	M8x1	0.03
	140x40	3.00	1.00	754.0	2100	E 2	2	140	117	100	120	310	210	243	22	275	200	25	310	80	37	10	40	215	115	M8x1	0.03
	140x60	4.50	1.50	616.7	1575	E 2	2	140	117	100	120	310	225	260	22	295	200	25	280	120	37	10	40	230	115	M8x1	0.03
	140x80	6.00	2.00	464.3	1048	E 2	2	140	117	100	120	310	225	260	22	295	200	25	260	160	37	10	40	230	115	M8x1	0.03
Z-1000	160x25	1.88	0.63	884.7	4068	E 2	2	160	142.8	130	175	340	225	260	22	295	-	25	345	50	31	13	40	230	170	M8x1	0.03
	160x40	3.00	1.00	1069.9	3016	E 2	2	160	132.8	130	175	340	260	300	22	340	250	40	310	80	31	13	40	265	170	M8x1	0.03
	160x60	4.50	1.50	663.0	1923	E 2	2	160	137	130	175	340	260	300	22	340	250	40	295	120	31	13	40	265	170	M8x1	0.03
	160x80	6.00	2.00	499.1	1282	E 2	2	160	137	130	175	340	260	300	22	340	250	40	275	160	31	13	40	265	170	M8x1	0.03

¹⁾ An extension may be required if a bellows or spiral spring is fitted
²⁾ Dynamic load rating to DIN 69051 part 4 draft 1989



Safety nut SIFA



Function

A safety nut is designed for use where stripping and break up of the thread could cause a hazard to persons.

A safety nut can also provide protection for other equipment against the consequences of machine failures and downtimes.

Wear

Once the wear exceeds max. 25% of the screw pitch, the load nut (R) or the gearbox (S) must be replaced.

Monitoring

Wear and thread play should be checked and documented at regular intervals (depending on the duty cycle).

This allows the fitting of replacement parts to be planned ahead, reducing unscheduled system downtime.

Electrical monitoring

Electrical monitoring gives a signal when wear reaches approx. 25%. This signal can be displayed immediately at a central control point. Replacement of the worn parts can then be scheduled.

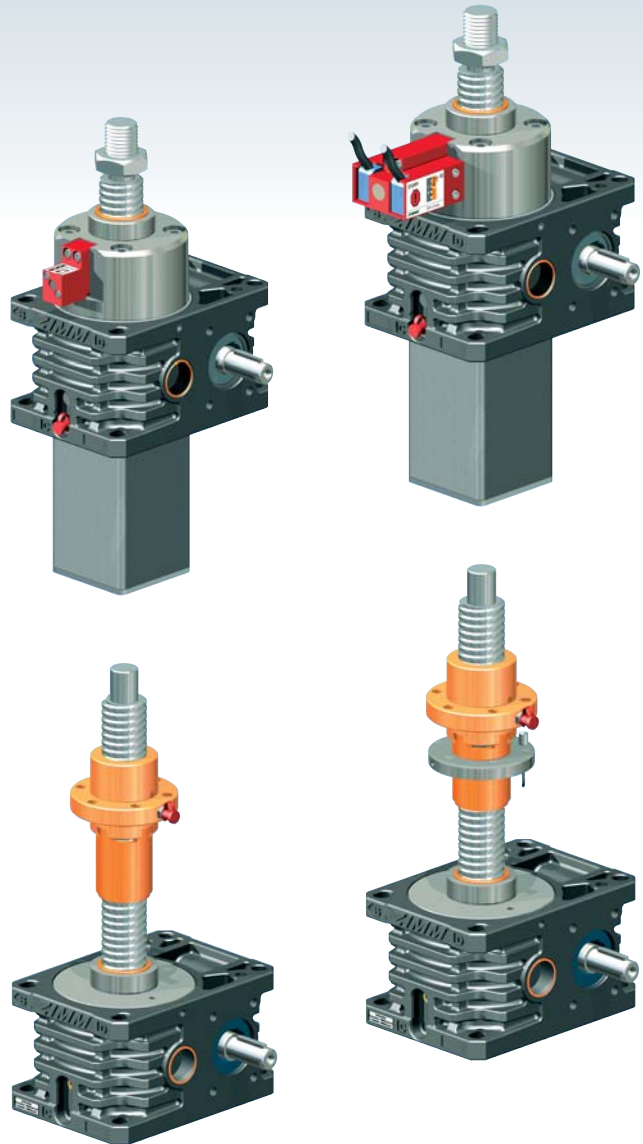

Screw jacks	Pitch P	max. permissible wear/ thread play* (25% of P)
[TrØxP]	[mm]	[mm]
Tr16x4, Tr18x4, Tr20x4	4	1.0
Tr30x6	6	1.5
Tr40x7	7	1.75
Tr50x8	8	2.0
Tr55x9, Tr60x9	9	2.25
Tr80x16, Tr100x16, Tr120x16	16	4.0
Tr140x20, Tr160x20	20	5.0

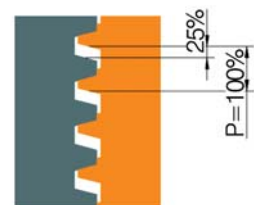

max. 25% wear

* Identical for double pitch screws (same thread flank thickness)



We have patents registered or pending for a range of functions and components.



SIFA-S translating screw

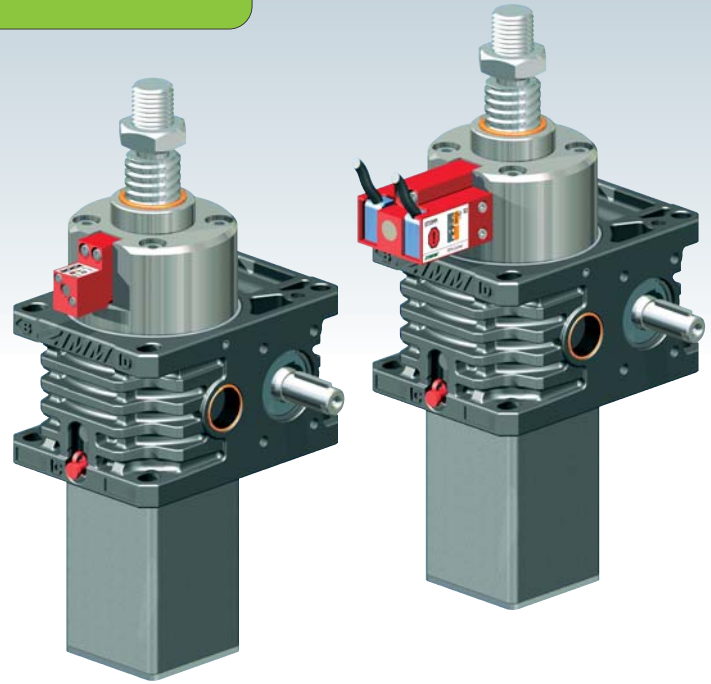
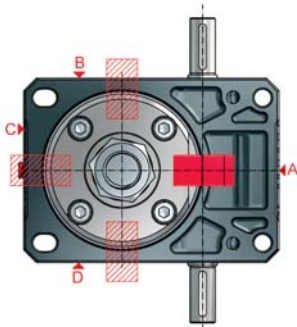
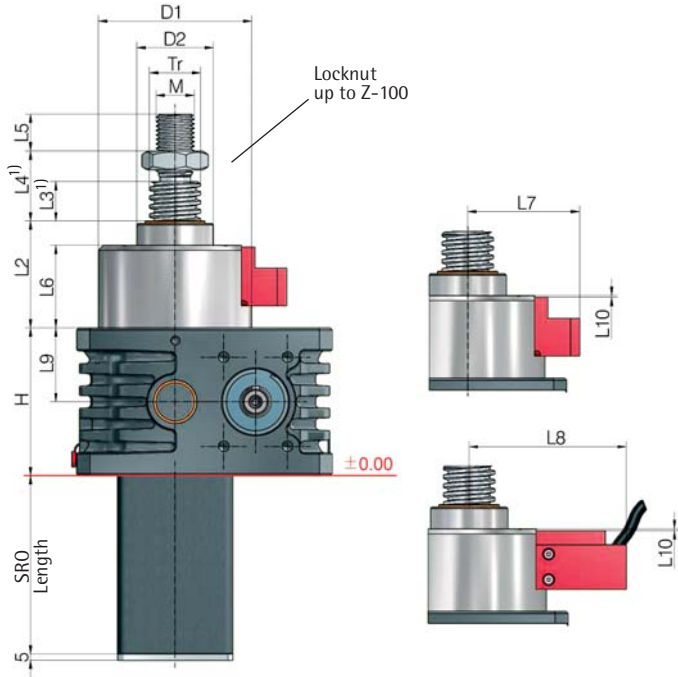

Function S version



The load is borne by the worm wheel via the screw. If the worm wheel screw thread wears through, the SIFA restrains the screw. The load remains supported.

Direction of loading, compressive and tensile
The new SIFA-S operates equally in both compressive and tensile directions of loading!



Ordering code:

Z-35-SN-SIFA-OP-A

Version
SN or SL
Monitoring
OP: visual
EL: electrical (wear, thread stripping)
ELV: only wear
ELD: only thread stripping
NO: without any monitoring
Position
A (standard), B, C or D
(can also subsequently be rotated steplessly through 360°)

i further technical information: Page 51

Screw jacks	Stroke travel/rev.		Tr thread	H	D1	D2	L2	L3 ¹⁾	L4 ¹⁾	L5	L6	L7	L8	L9	L10	M
	SN	SL														
Z-10	1	0.25	20x4	74	81	39	74	10	22	20	58	72	108	21	1	M14
Z-25	1	0.25	30x6	82	92	46	76	10	26	22	59	79	114	25	1	M20
Z-35	1	0.25	40x7	100	100	60	80	10	34	29	61	82	117	50	1	M30
Z-50	1	0.25	40x7	116	120	60	84	10	34	29	65	88	123	58	1	M30
Z-100	1	0.25	55x9	160	135	85	103	20	48	48	73	95	130	80	9	M36
Z-150	1	0.25	60x9	185	161	90	113	20	20	48	81	107	141	92.5	6	M42x2
Z-250	1.5	0.50	80x16	193	210	120	169	20	20	58	137	117	152	91	13	M56x2

up to Z-1000 on request

¹⁾ See Section 8 for extension if bellows or spiral spring is fitted

SIFA-S, monitoring

Visual

Monitoring

Wear should be checked and documented at regular intervals. This allows the fitting operation for replacement to be planned in good time so as to avoid system downtime.

OK
Wear still <25% of P

CAUTION!
max. permissible wear reached –
Replace the gearbox

STOP!
Wear >25% or thread already worn through –
Stop operation immediately!

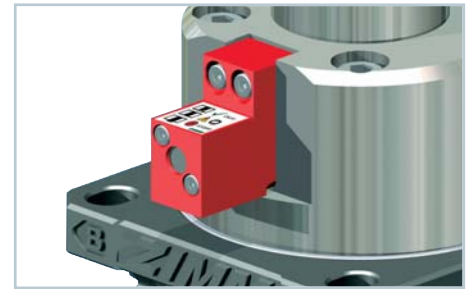
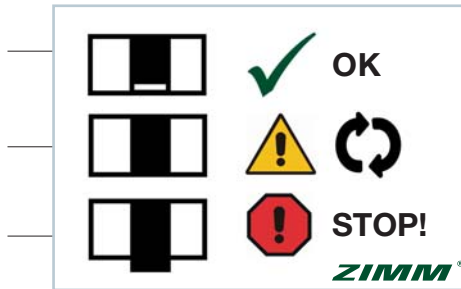

Electrical

WARNING! Switch S1
At 25% wear the limit switch S1 trips.
The customer must detect this signal.
This enables substitution to be planned well
in advance and therefore prevents any
unnecessary downtime.



STOP! Switch S2
If after the first signal operation of the jack
continues, the nut will continue to wear until
the thread is worn through. When the thread
is worn through, the safety nut takes the load.
The limit switch S2 trips.
The customer must detect this signal and
stop the system.

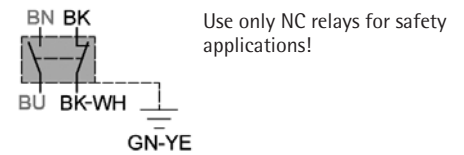
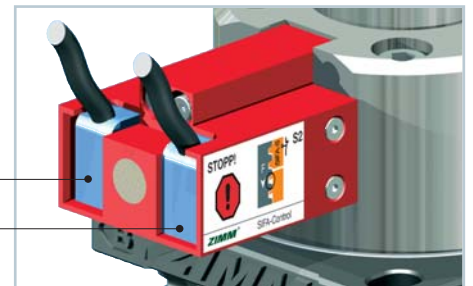

Without any monitoring

If the version used has no monitoring,
the dimension A must be measured and
documented when new, then regularly
checked and documented.

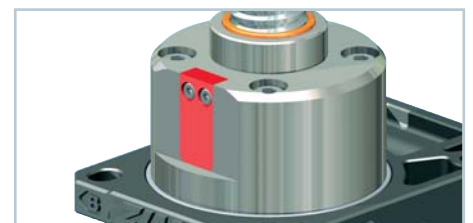
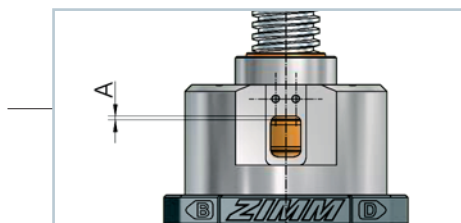



SIFA-R rotating screw

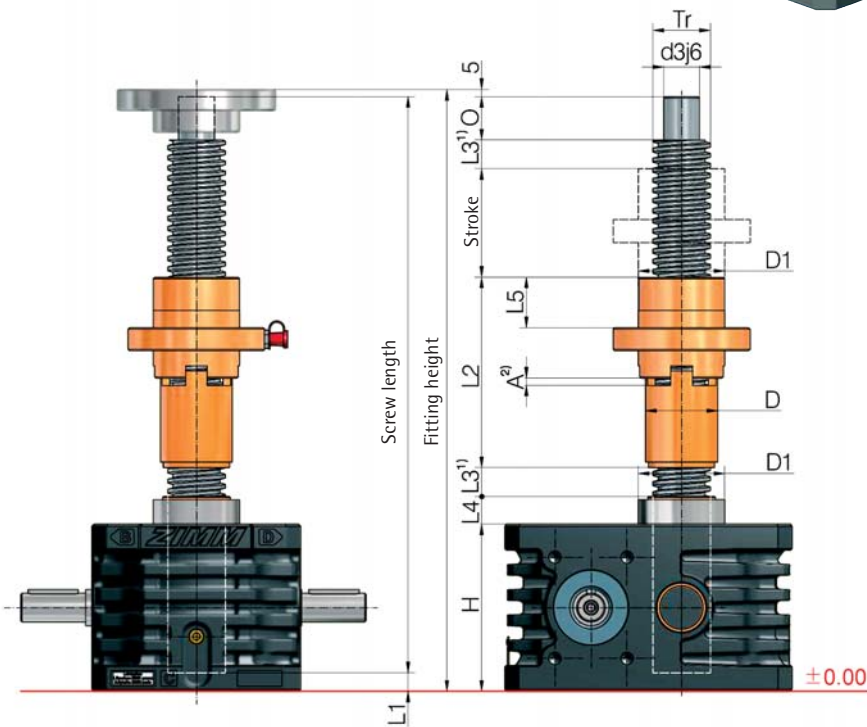
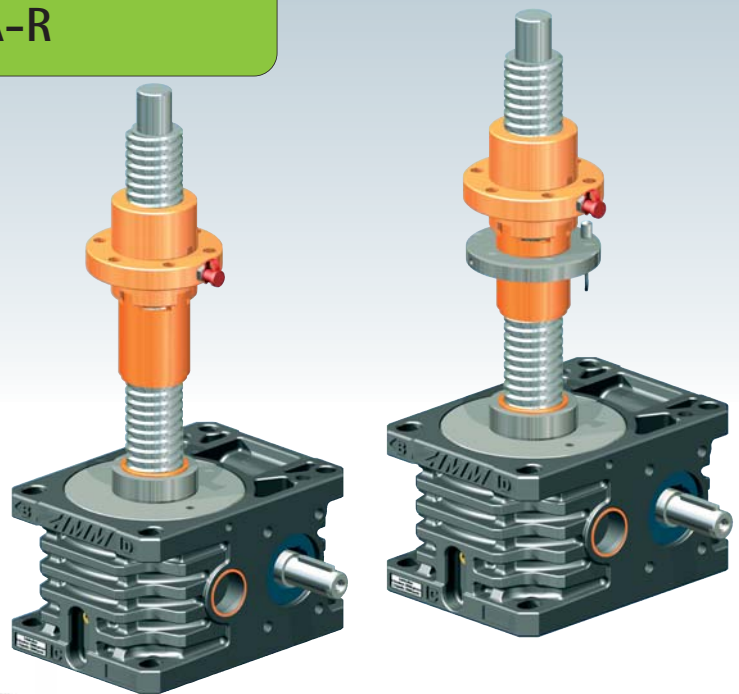

Function R version



The load is borne by the duplex nut. The safety nut runs alongside the duplex nut, bearing no load. If the nut thread is worn through due to wear, the SIFA takes the load.

Direction of loading, tensile or compressive
A drawing showing the direction of loading is necessary in order to ensure the safety function. The SIFA-R operates in only one direction of loading.

- further technical information: Page 51
- see the respective screw jack page for all other dimensions
- see Section 4 for accessories
- SIFA in combination with self-aligning nut PM available on request

Screw jacks	Tr thread	H	D1	D	d3j6	O	L1	L2	L3 ¹⁾	L4	L5	A ²⁾
Z-5	18x4	62	29	24	12	15	8	70	10	12	20	3
Z-10	20x4	74	39	28	15	20	8	84	10	16	20	3
Z-25	30x6	82	46	38	20	25	5	95	10	17	23	4
Z-35	40x7	100	60	50	25	30	7	133	10	19	36	4
Z-50	40x7	116	60	50	25	30	7	133	10	19	36	4
Z-100	55x9	160	85	65	40	45	8	173	20	30	54	6
Z-150	60x9	185	90	70	45	55	7	211	20	32	75	6
Z-250	80x16	193	120	100	60	75	5	250	20	37	85	9
Z-350	100x16	230	150	120	80	100	6	270	20	24	100	9
Z-500	120x16	260	170	135	95	120	6	303	40	32	110	9
Z-750	140x20	310	200	170	100	120	10	365	40	37	140	12
Z-1000	160x20	340	250	190	130	175	13	500	40	32	210	12

¹⁾ see Section 8 for extension if bellows or spiral spring is fitted
²⁾ approx. original setting, must be measured and documented by the customer, and referred to when checking

Make sure you fit it the right way up:

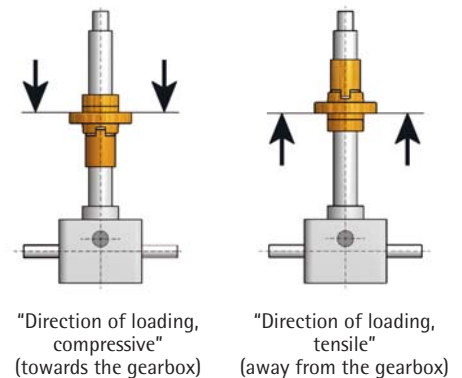

SIFA-R, monitoring

Visual

Dimension A is approx. the original setting. Dimension A must be measured and documented by the customer, and referred to when checking. This enables substitution to be planned well in advance and therefore prevents any unnecessary downtime. When the thread is worn through, take the equipment out of service immediately.

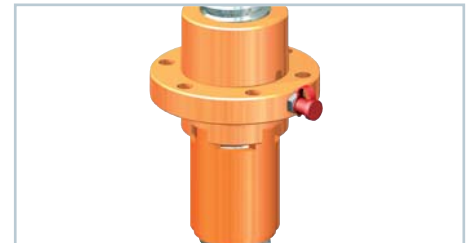
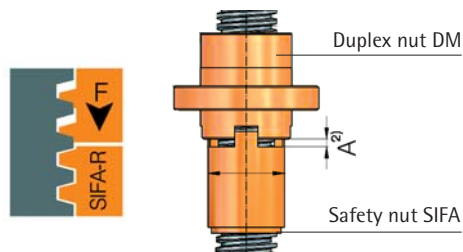

Electrical

The initiator must be set that it switches off when the load nut reaches 25% of the wear. This enables a replacement to be planned well in advance and therefore prevents any unnecessary downtime. When the thread is worn through, take the system out of service immediately.

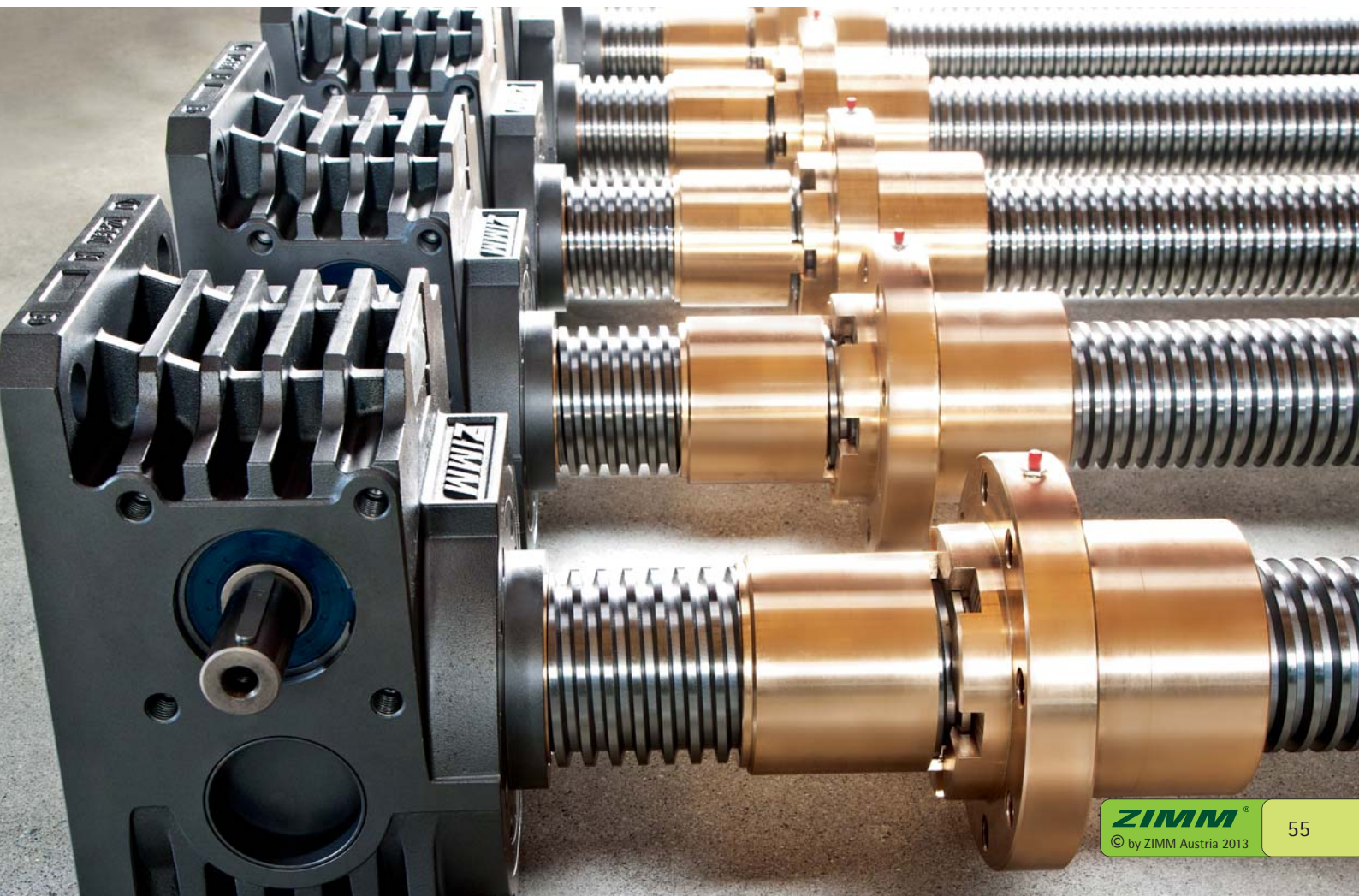
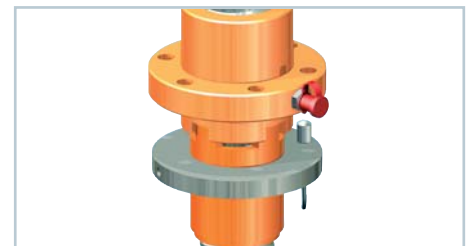
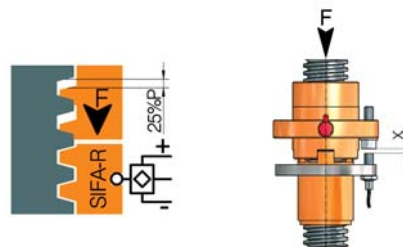

GSZ series

GSZ series screw jacks are designed for applications where smooth surfaces are required. These screw jacks are easier to clean and therefore ideal for applications in the food processing industry.

Smooth surface

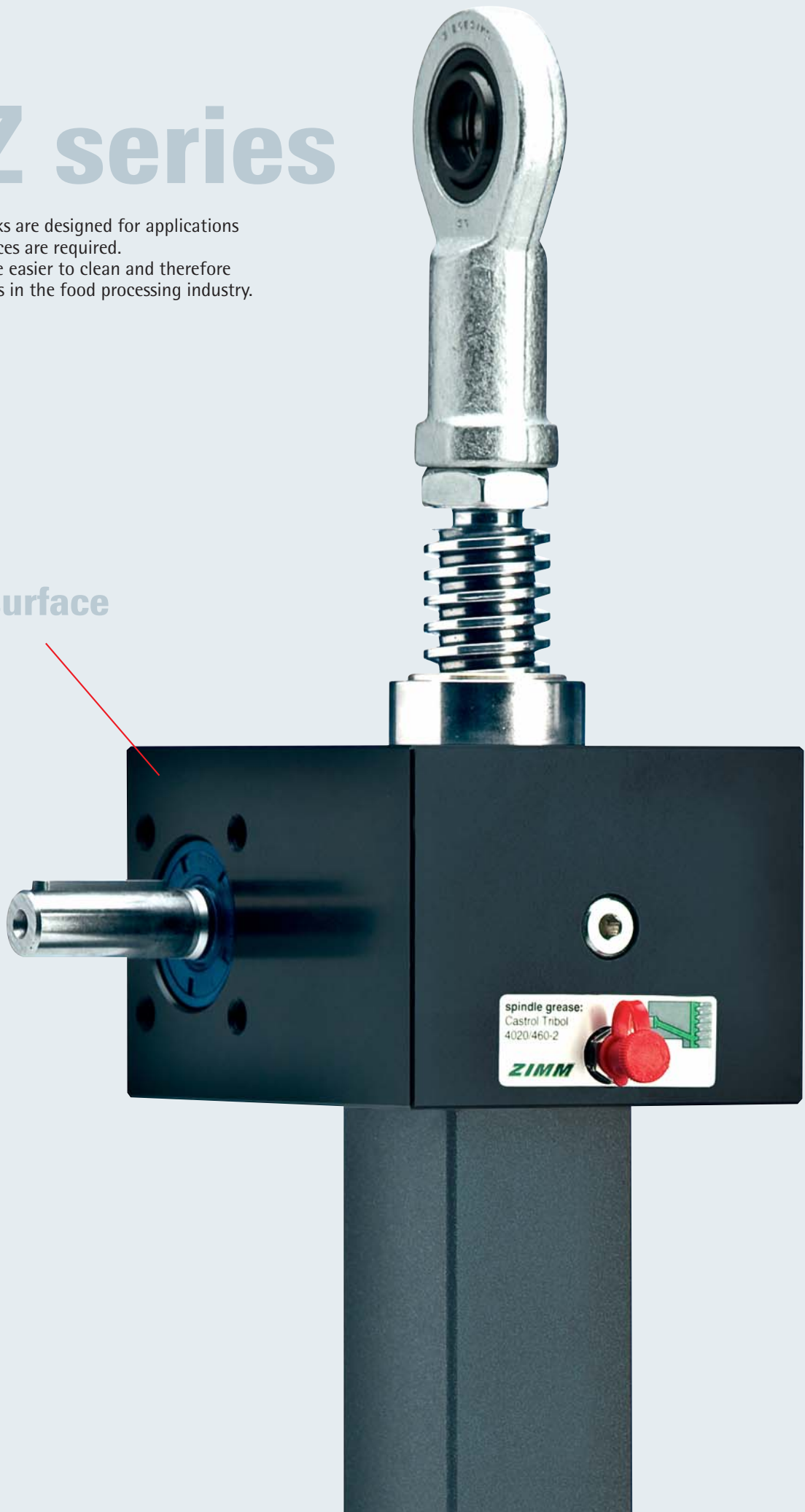

Types and sizes

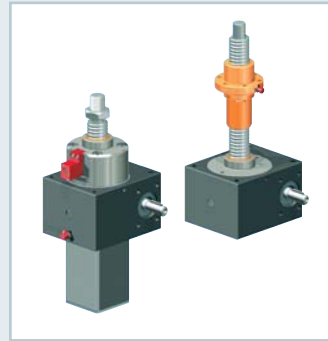
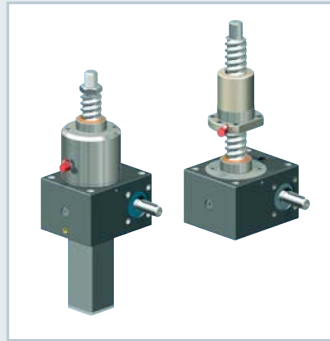
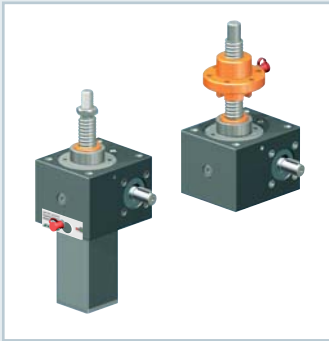

GSZ series jacks Tr
Trapezoidal screw
2.5 kN to 100 kN

Pages 58 - 69



GSZ series jacks KGT
Ball screw
2.5 kN to 100 kN

Pages 70 - 73



GSZ series jacks SIFA
Safety nut
2.5 kN to 100 kN

Pages 74 - 79



We have patents registered or pending for a range of functions and components.



UNIQUE:
Screw lubrication
during operation

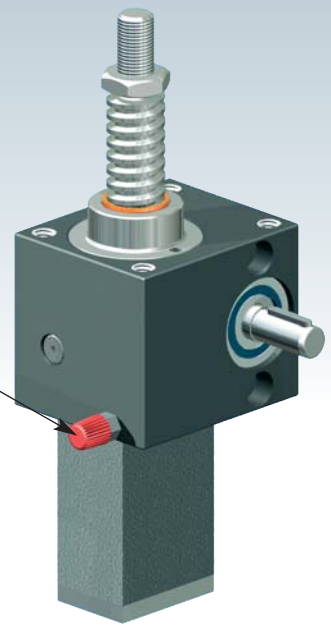

GSZ-2-S translating screw 2.5 kN

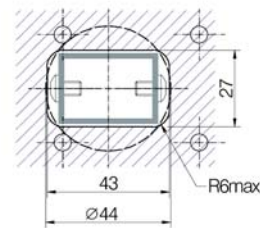
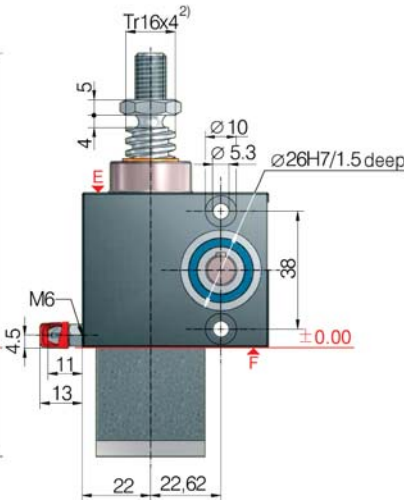
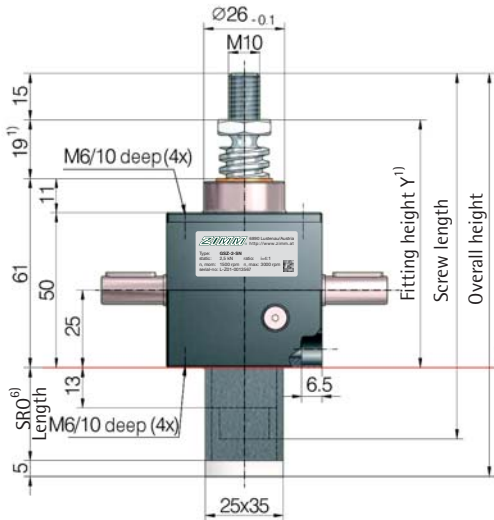

Opening for protective tube SRO, rectangular 43x27 or round Ø 44

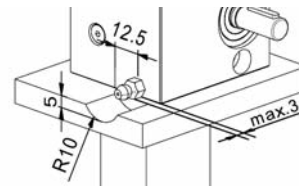

Minimum space requirement for greasing the screw (grease gun)

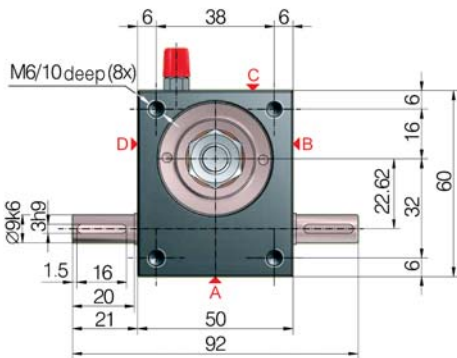

¹)Fitting height "Y" for 0-stroke, with Tr 16x4 screw

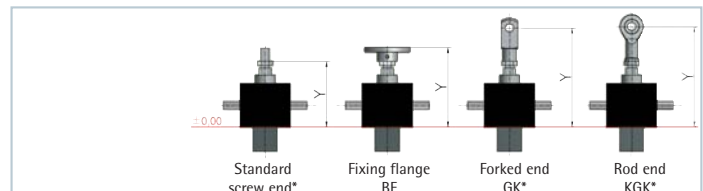

All dimensions in mm

Bellocs FB	Y	Y	Y	Y
without bellocs FB	80	96	120	123
GSZ-2-FB-182	117	116	157	160
GSZ-2-FB-364	177	176	217	220

*with bellocs fixing ring Z-2-FBR

⁶)Protective tube length SRO with Tr 16x4 screw

Without escape/ rotation protection	Escape/ rotation protection	Rotation protection, with limit switch set ES	Rotation protection with ES and KAR*
47+stroke	62+stroke	117+stroke	139+stroke

*Hinged bearing plate KAR, fitted on face F (below).

Standard ratios

Type	Verison	Speed	Standard screw²)	i	Stroke per drive shaft rotation⁵)
GSZ-2-SN	Translating	Normal	Tr 16x4	4:1	1.00 mm
GSZ-2-SL	screw	Low speed		16:1	0.25 mm
GSZ-2-RN	Rotating	Normal	Tr 16x4	4:1	1.00 mm
GSZ-2-RL	screw	Low speed		16:1	0.25 mm

Screw jack mounting

max. load: 2.5 kN compressive and tensile load
Screw: M6, strength class 8.8
Screw-in depth: 8 to 10 mm
Tightening torque: 8 Nm
Screw locking: with Loctite 243

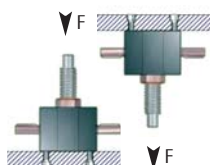

Duty cycle thermal limit, for S+R

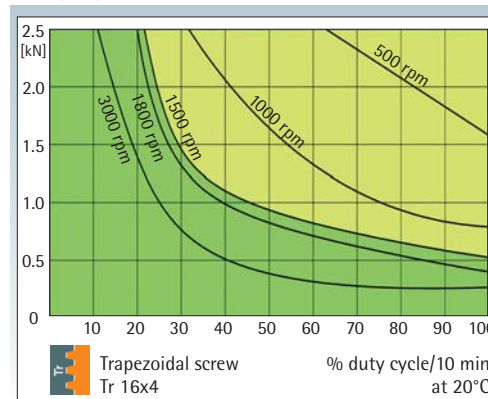

These curves are for guidance under standard industrial conditions (ambient temperature etc.) and correct maintenance (lubrication etc.). The max. input drive torques for optimum service life are at the right page - technical data (1500 rpm)

KGK: % duty cycle 2 times to 4 times higher

Trapezoidal screw

Tr



GSZ-2-R rotating screw 2.5 kN

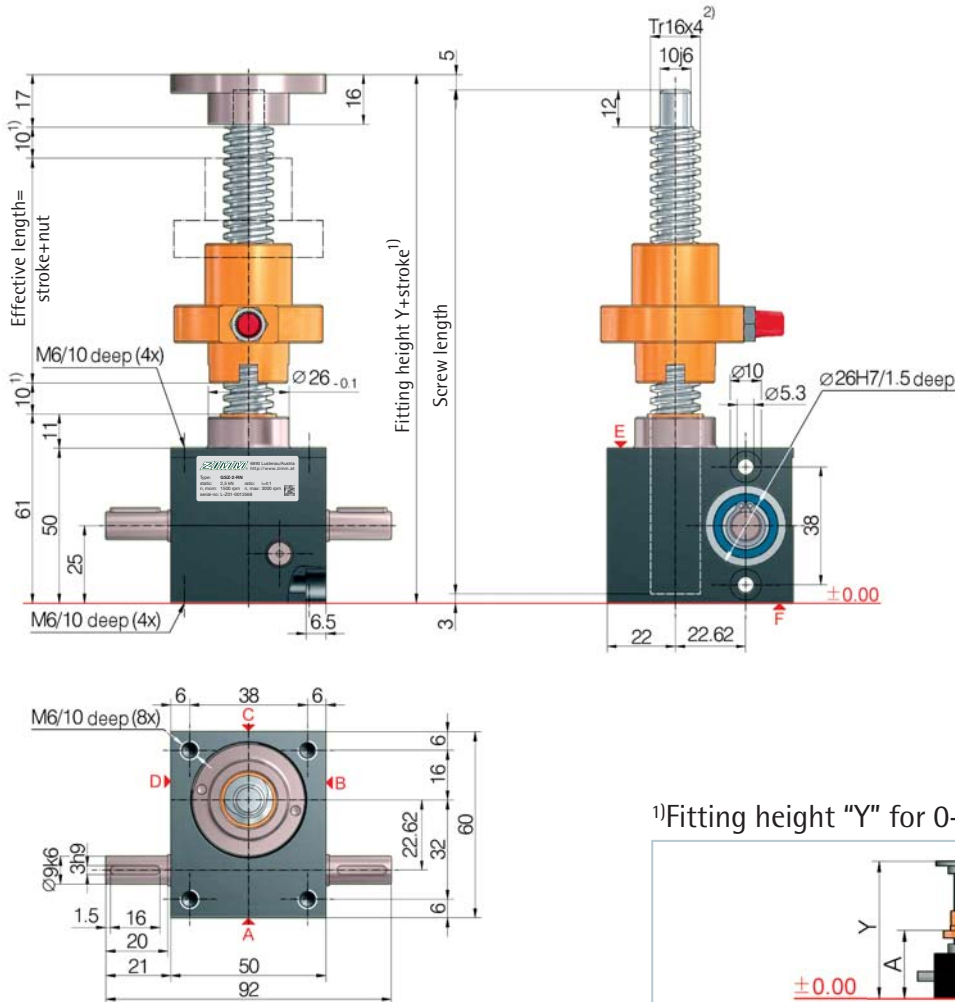
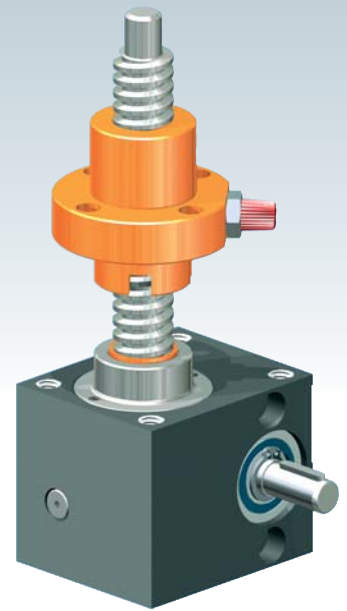

¹⁾Fitting height "Y" for 0-stroke, with Tr 16x4 screw

All dimensions in mm	Flange nut FM	Duplex nut DM	Duplex nut DM with SIFA
Bellows FB	Y/A	Y/A	Y/A
without bellows FB	132/83	142/96	167/121
2x GSZ-2-FB-182	-	198/124	220/146
2x GSZ-2-FB-364	-	318/184	340/206

Detailed instructions for determining the length can be found in Section 8

2.5 kN

Technical data series GSZ-2-S / GSZ-2-R

max. compressive/tensile force, static	- 2.5 kN (250 kg)
max. compressive/tensile force, dynamic	- see duty cycle curves
Nominal speed	- 1500 rpm
max. drive shaft speed	- 3000 rpm (depending on the load and duty cycle)
Screw size standard	- Tr 16x4 ²⁾
Gear ratio	- 4:1 (N) / 16:1 (L)
Housing material	- aluminium, corrosion-resistant
Worm shaft	- stainless steel, ground
Weight of screw jack body	- 0.6 kg
Weight of screw/m	- 1.21 kg
Gearbox lubrication	- synthetic fluid grease
Screw lubrication	- grease lubrication
Gearbox operating temperature	- max. 60°C, higher on request
Moment of inertia	- N: 0.081 kg cm ² / L: 0.037 kg cm ²
Input torque (at 1500 rpm)	- max. 1.4 Nm (N) / max. 0.5 Nm (L)
Drive-through torque	- max. 9 Nm

Drive torque M_0 (Nm)	- F (kN) \times 0.52 ³⁾⁵⁾ + M_L (N-normal)
Breakaway torque	- F (kN) \times 0.15 ³⁾⁵⁾ + M_L (L-low speed)
Idling torque ⁴⁾ M_L (Nm)	- Drive torque $M_0 \times 1.5$
	- 0.08 (N-normal) / 0.06 (L-low speed)

Between gearbox and nut or nut and end of thread, provide for a safety distance of (minimum) 10 mm!
See Section 7 for the checklist.

Important information

- 1) - extension if a bellows is fitted: see the table or Section 8
- 2) - Tr 16x4 is standard, also available: double-pitch, stainless steel, left-handed, increased screw Tr 18x4 (only for the R version)
- 3) - factor includes efficiency, ratio and 30% safety
- 4) - at 20°C, can be higher when new
- 5) - for a 4 mm screw pitch

Trapezoidal screw

Tr



GSZ-5-R rotating screw 5 kN

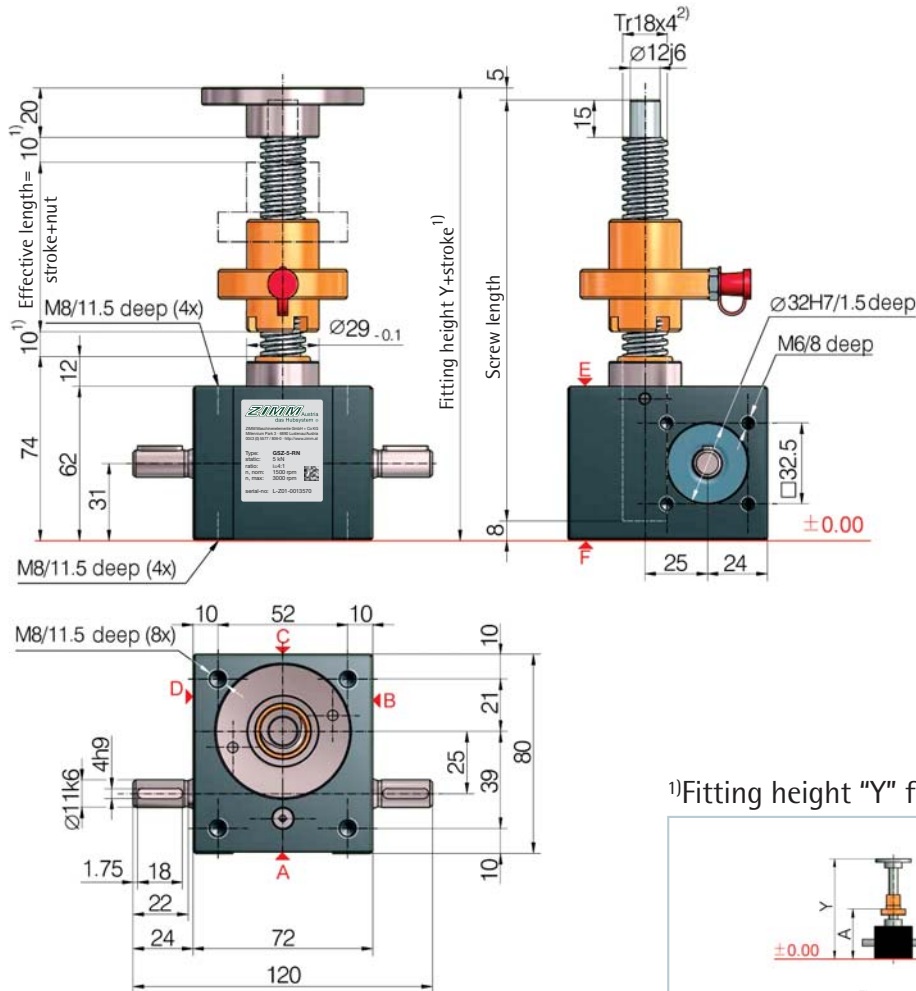
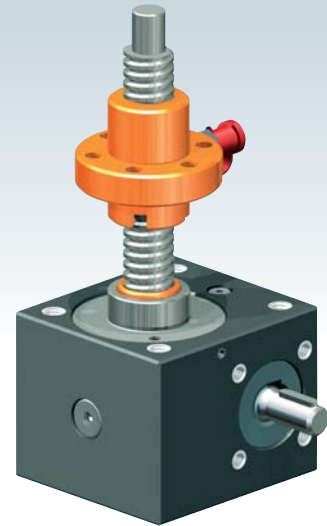

¹⁾Fitting height "Y" for 0-stroke, with Tr 18x4 screw

All dimensions in mm	Flange nut FM	Duplex nut DM	Duplex nut DM with SIFA	Self-aligning nut PM	Greasless nut FFDM
Bellocs FB	Y/A	Y/A	Y/A	Y/A	Y/A
without bellocs FB	149/96	159/109	184/134	192/141	167/117
2x Z-5-FB-265	-	207/132	229/154	240/164	215/140
2x Z-5-FB-500	-	337/197	359/219	370/229	345/205
2x Z-5-FB-800	-	377/217	399/239	410/249	385/225

Detailed instructions for determining the length can be found in Section 8

5

kN

Technical data series GSZ-5-S / GSZ-5-R

max. compressive/tensile force, static	- 5 kN (500 kg)
max. compressive/tensile force, dynamic	- see duty cycle curves
Nominal speed	- 1500 rpm
max. drive shaft speed	- 3000 rpm (depending on the load and duty cycle)
Screw size standard	- Tr 18x4 ²⁾
Gear ratio	- 4:1 (N) / 16:1 (L)
Housing material	- aluminium, corrosion-resistant
Worm shaft	- steel, case-hardened, ground
Weight of screw jack body	- 1.2 kg
Weight of screw/m	- 1.58 kg
Gearbox lubrication	- synthetic fluid grease
Screw lubrication	- grease lubrication
Gearbox operating temperature	- max. 60°C, higher on request
Moment of inertia	- N: 0.217 kg cm ² / L: 0.117 kg cm ²
Input torque (at 1500 rpm)	- max. 4.7 Nm (N) / max. 1.5 Nm (L)
Drive-through torque	- max. 39 Nm

Drive torque M_0 (Nm)	- F (kN) \times 0.62 ³⁾⁵⁾ + M_L (N-normal)
Breakaway torque	- F (kN) \times 0.21 ³⁾⁵⁾ + M_L (L-low speed)
Idling torque ⁴⁾ M_L (Nm)	- Drive torque $M_0 \times 1.5$ - 0.10 (N-normal) / 0.08 (L-low speed)

Between gearbox and nut or nut and end of thread, provide for a safety distance of (minimum) 10 mm!
See Section 7 for the checklist.

Important information

- 1) - extension if a bellows or spiral spring is fitted: see the table or Section 8
- 2) - Tr 18x4 is standard, also available: double-pitch, stainless steel, left-handed, increased screw Tr 20x4 (only for the R version)
- 3) - factor includes efficiency, ratio and 30% safety
- 4) - at 20°C, can be higher when new
- 5) - for a 4 mm screw pitch



UNIQUE:
Screw lubrication
during operation

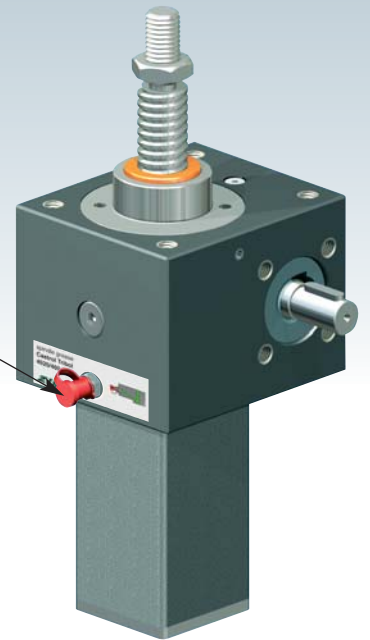

GSZ-10-S translating screw 10 kN

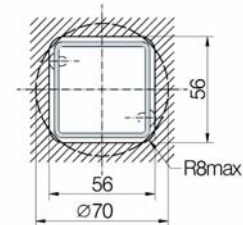
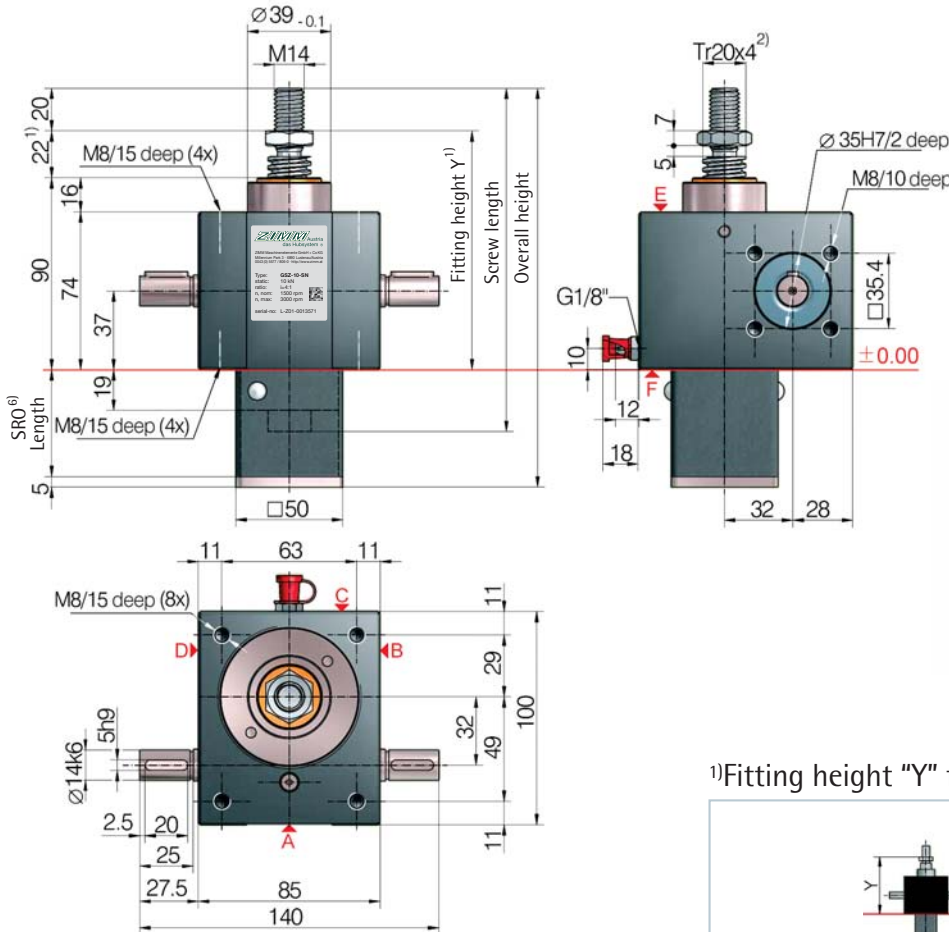

6) Protective tube length SRO with Tr 20x4 screw

Without escape/ rotation protection	Escape/ rotation protection	Rotation protection, with limit switch set ES	Rotation protection with ES and KAR*
49+stroke	69+stroke	121+stroke	141+stroke

*Hinged bearing plate KAR, fitted on face F (below).

1) Fitting height "Y" for 0-stroke, with Tr 20x4 screw

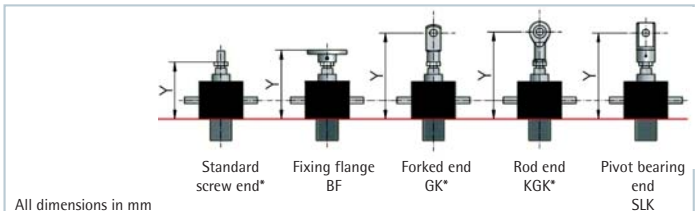

Bellocs FB	Y	Y	Y	Y	Y
without bellocs FB	112	133	168	173	168
Z-10-FB-340	193	189	249	254	224
Z-10-FB-700	213	209	269	274	244
Z-10-FB-1000	263	259	319	324	294

*with bellocs fixing ring Z-10-FBR

Standard ratios

Type	Version	Speed	Standard screw ²⁾	i	Stroke per drive shaft rotation ⁵⁾
GSZ-10-SN	Translating	Normal	Tr 20x4	4:1	1.00 mm
GSZ-10-SL	screw	Low speed		16:1	0.25 mm
GSZ-10-RN	Rotating	Normal	Tr 20x4	4:1	1.00 mm
GSZ-10-RL	screw	Low speed		16:1	0.25 mm

Screw jack mounting

max. load: 10 kN compressive and tensile load
Screw: M8, strength class 8.8
Screw-in depth: 10 to 15 mm
Tightening torque: 17 Nm
Screw locking: with Loctite 243

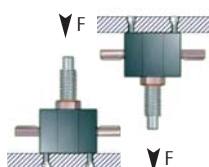

Duty cycle thermal limit, for S+R

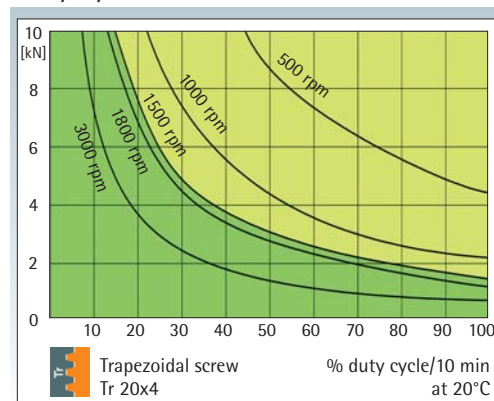

These curves are for guidance under standard industrial conditions (ambient temperature etc.) and correct maintenance (lubrication etc.). The max. input drive torques for optimum service life are at the right page - technical data (1500 rpm)

KGK: % duty cycle 2 times to 4 times higher



GSZ-10-R rotating screw 10 kN

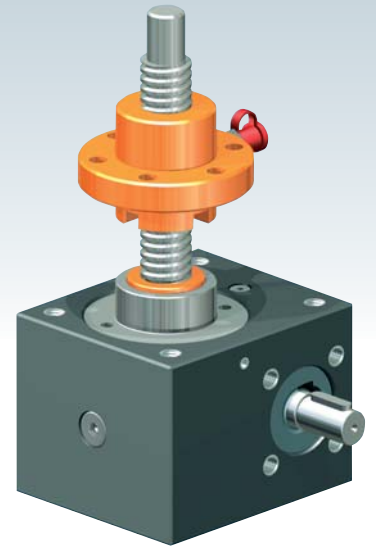
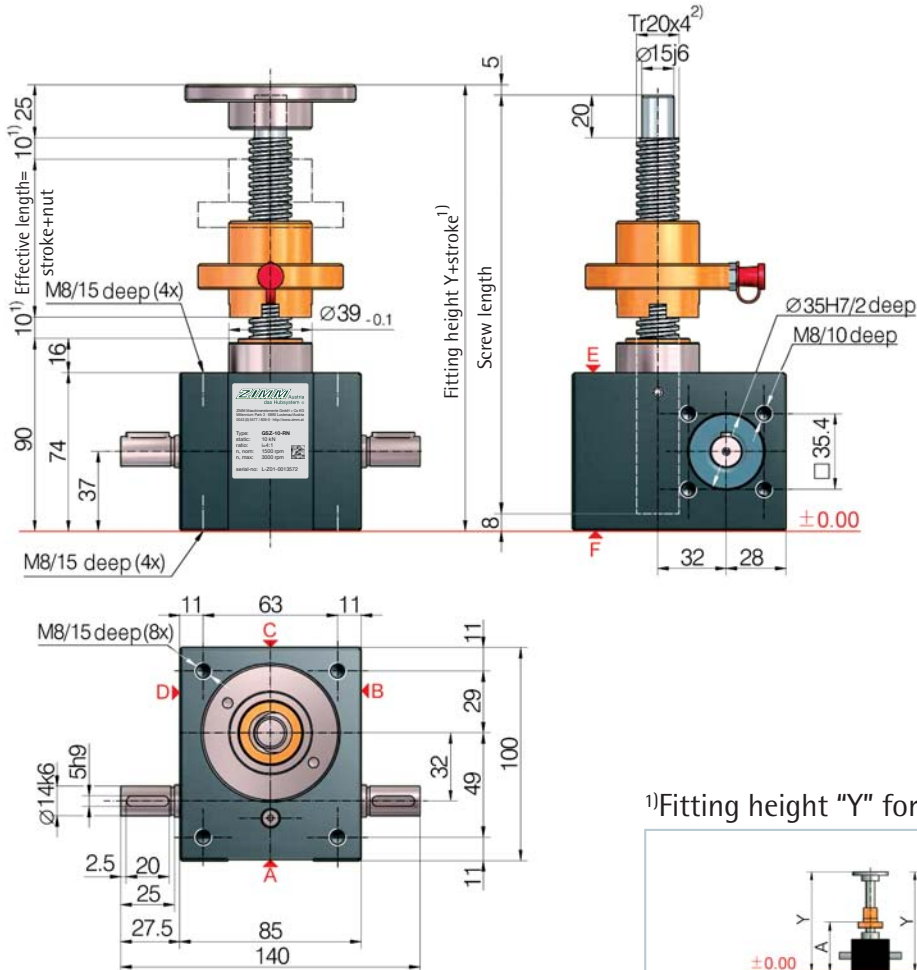

¹⁾Fitting height "Y" for 0-stroke, with Tr 20x4 screw

All dimensions in mm	Flange nut FM	Duplex nut DM	Duplex nut DM with SIFA	Self-aligning nut PM	Greasless nut FFDM
Bellows FB	Y/A	Y/A	Y/A	Y/A	Y/A
without bellows FB	179/112	180/125	219/164	218/159	188/133
2x Z-10-FB-340	-	314/193	350/229	352/227	322/201
2x Z-10-FB-700	-	354/213	390/249	392/247	362/221
2x Z-10-FB-1000	-	454/263	490/299	492/297	462/271

Detailed instructions for determining the length can be found in Section 8

10 kN

Technical data series GSZ-10-S / GSZ-10-R

max. compressive/tensile force, static	- 10 kN (1 t)
max. compressive/tensile force, dynamic	- see duty cycle curves
Nominal speed	- 1500 rpm
max. drive shaft speed	- 3000 rpm (depending on the load and duty cycle)
Screw size standard	- Tr 20x4 ²⁾
Gear ratio	- 4:1 (N) / 16:1 (L)
Housing material	- aluminium, corrosion-resistant
Worm shaft	- steel, case-hardened, ground
Weight of screw jack body	- 2.1 kg
Weight of screw/m	- 2 kg
Gearbox lubrication	- synthetic fluid grease
Screw lubrication	- grease lubrication
Gearbox operating temperature	- max. 60°C, higher on request
Moment of inertia	- N: 0.641 kg cm ² / L: 0.271 kg cm ²
Input torque (at 1500 rpm)	- max. 13.5 Nm (N) / max. 7.5 Nm (L)
Drive-through torque	- max. 57 Nm

Drive torque M_0 (Nm)	- F (kN) \times 0.64 ³⁾ + M_L (N-normal)
Breakaway torque	- F (kN) \times 0.20 ³⁾ + M_L (L-low speed)
Idling torque ⁴⁾ M_L (Nm)	- Drive torque $M_0 \times 1.5$
	- 0.26 (N-normal) / 0.16 (L-low speed)

Between gearbox and nut or nut and end of thread, provide for a safety distance of (minimum) 10 mm!
See Section 7 for the checklist.

Important information

- extension if a bellows or spiral spring is fitted: see the table or Section 8
- Tr 20x4 is standard, also available: double-pitch, stainless steel, left-handed, increased screw Tr 30x6 (only for the R version)
- factor includes efficiency, ratio and 30% safety
- at 20°C, can be higher when new
- for a 4 mm screw pitch

Trapezoidal screw

Tr



GSZ-25-R rotating screw 25 kN

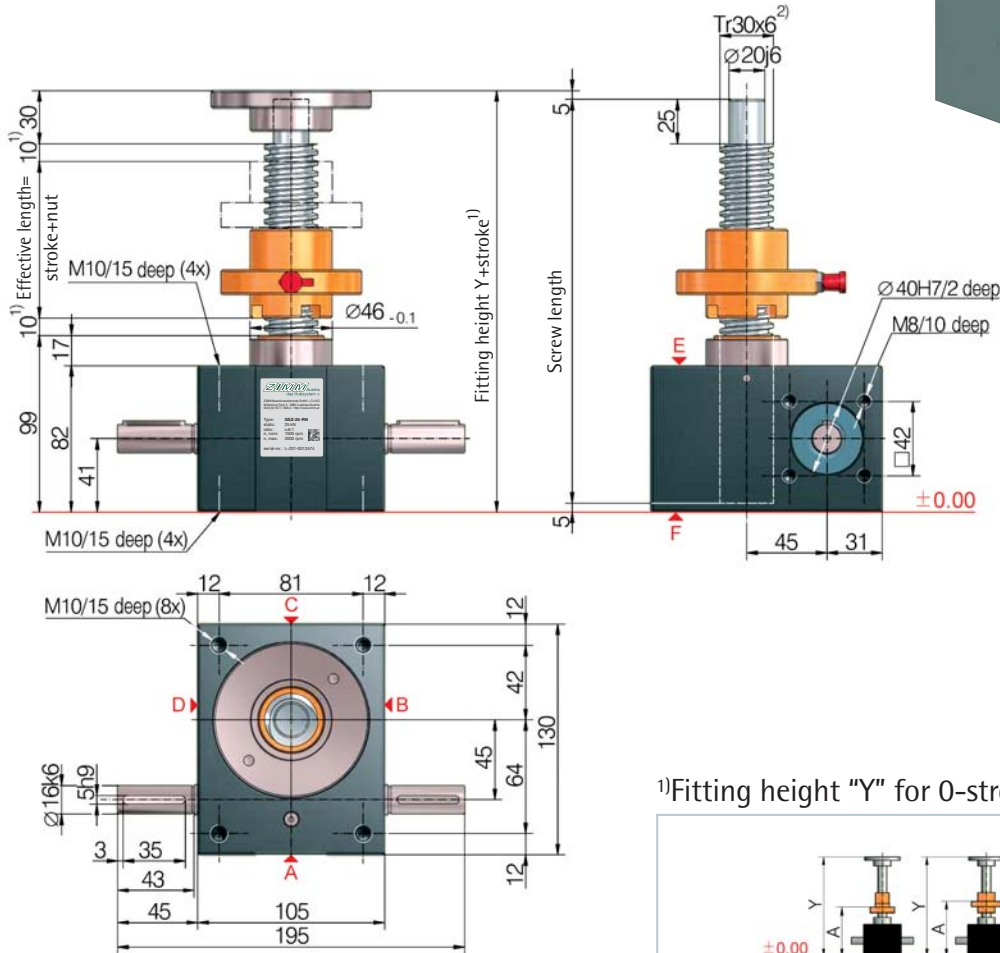
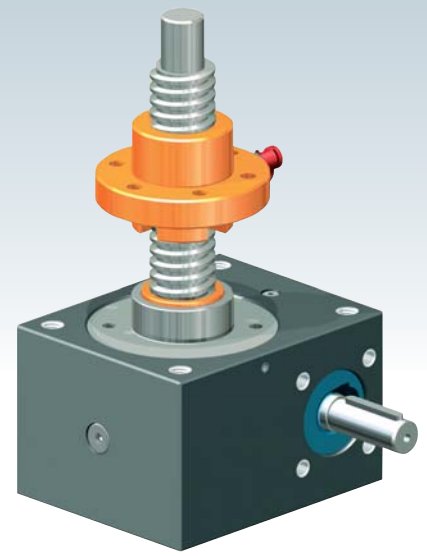

¹⁾Fitting height "Y" for 0-stroke, with Tr 30x6 screw

All dimensions in mm	Flange nut FM	Duplex nut DM	Duplex nut DM with SIFA	Self-aligning nut PM	Greasless nut FFDM
Bellows FB	Y/A	Y/A	Y/A	Y/A	Y/A
without bellows FB	195/123	199/136	244/181	244/177	208/145
2x Z-25-FB-300	-	314/196	353/235	359/237	325/207
2x Z-25-FB-700	-	374/226	413/265	419/267	385/237
2x Z-25-FB-1000	-	414/246	453/285	459/287	425/257

Detailed instructions for determining the length can be found in Section 8

25 kN

Technical data series GSZ-25-S / GSZ-25-R

max. compressive/tensile force, static	- 25 kN (2.5 t)
max. compressive/tensile force, dynamic	- see duty cycle curves
Nominal speed	- 1500 rpm
max. drive shaft speed	- 3000 rpm (depending on the load and duty cycle)
Screw size standard	- Tr 30x6 ²⁾
Gear ratio	- 6:1 (N) / 24:1 (L)
Housing material	- aluminium, corrosion-resistant
Worm shaft	- steel, case-hardened, ground
Weight of screw jack body	- 3.8 kg
Weight of screw/m	- 4.5 kg
Gearbox lubrication	- synthetic fluid grease
Screw lubrication	- grease lubrication
Gearbox operating temperature	- max. 60°C, higher on request
Moment of inertia	- N: 1.449 kg cm ² / L: 0.589 kg cm ²
Input torque (at 1500 rpm)	- max. 18 Nm (N) / max. 10 Nm (L)
Drive-through torque	- max. 108 Nm

Drive torque M_G (Nm)	- F (kN) x 0.63 ³⁾ (N-normal)
	- F (kN) x 0.20 ³⁾ (L-low speed)
Breakaway torque	- Drive torque M_G x 1.5
Idling torque ⁴⁾ M_L (Nm)	- 0.36 (N-normal) / 0.26 (L-low speed)

Between gearbox and nut or nut and end of thread, provide for a safety distance of (minimum) 10 mm!

See Section 7 for the checklist.

Important information

- 1) - extension if a bellows or spiral spring is fitted: see the table or Section 8
- 2) - Tr 30x6 is standard, also available: double-pitch, stainless steel, left-handed, increased screw Tr 40x7 (only for the R version)
- 3) - factor includes efficiency, ratio and 30% safety
- 4) - at 20°C, can be higher when new
- 5) - for a 6 mm screw pitch



UNIQUE:
Screw lubrication
during operation

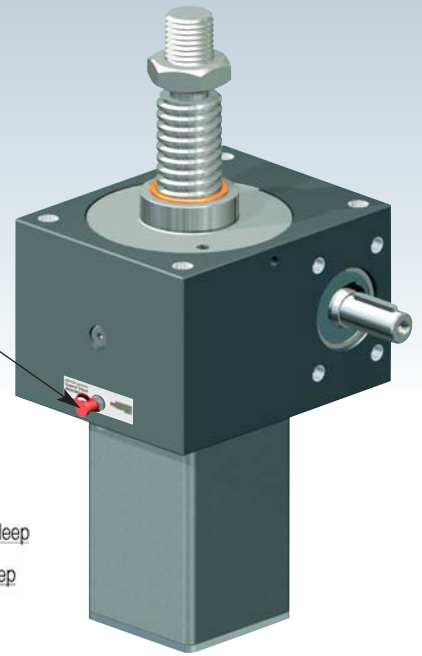

GSZ-50-S translating screw 50 kN

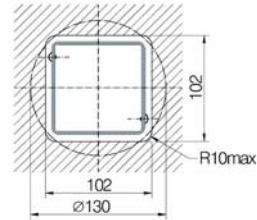
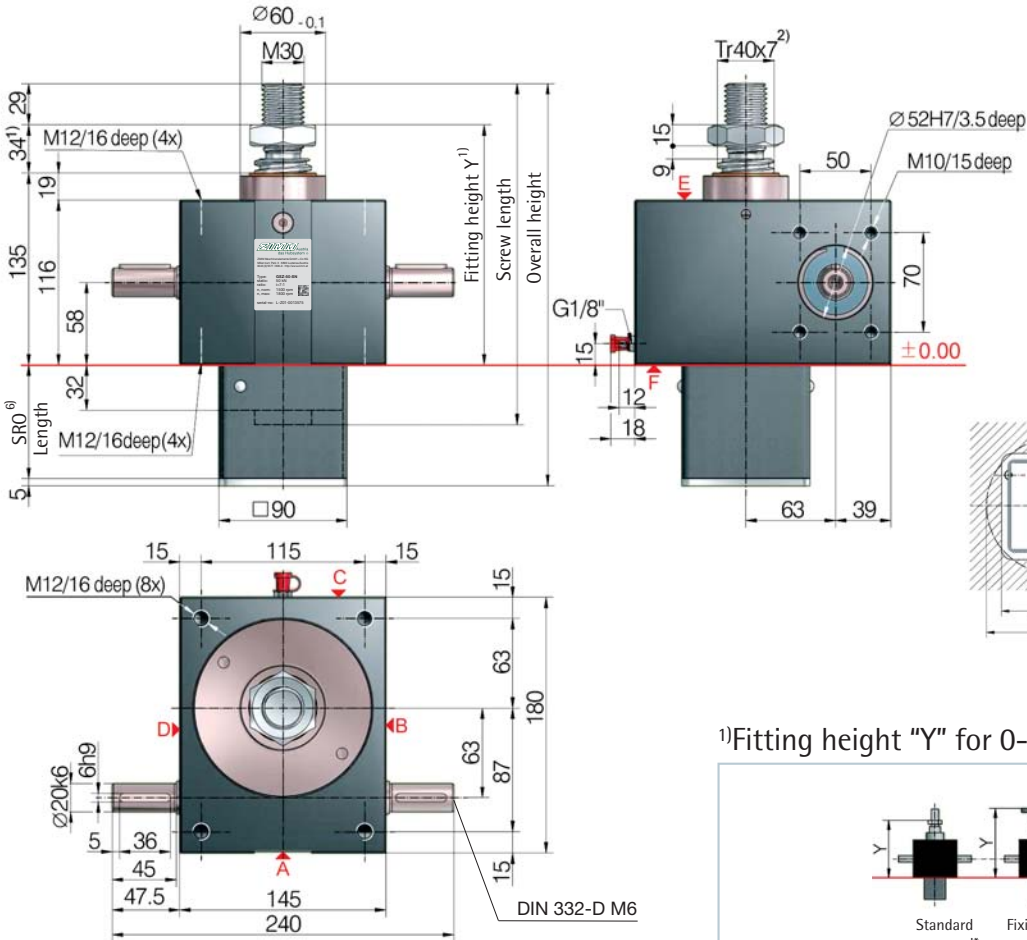

Opening for
protective tube SRO
square 102x102
or round Ø 130

1) Fitting height "Y" for 0-stroke, with Tr 40x7 screw

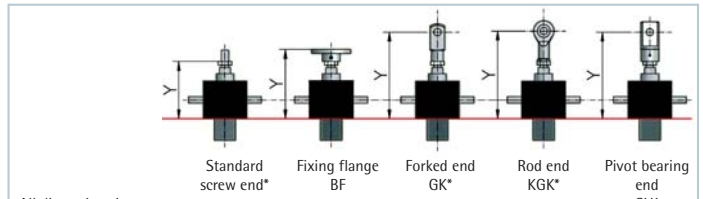

All dimensions in mm

Bellocs FB	Y	Y	Y	Y	Y
without bellocs FB	169	199	289	279	261
Z-50-FB-390	264	248	384	374	310
Z-50-FB-600	251	235	371	361	297
Z-50-FB-1000	309	293	429	419	355
Z-50-FB-1200	304	288	424	414	350
Z-50-FB-1500	359	343	479	469	405

*with bellows fixing ring Z-50-FBR

6) Protective tube length SRO with Tr 40x7 screw

Without escape/ rotation protection	Escape/ rotation protection	Rotation protection, with limit switch set ES	Rotation protection with ES and KAR*
62+stroke	92+stroke	144+stroke	169+stroke

*Hinged bearing plate KAR, fitted on face F (below).

Standard ratios

Type	Version	Speed	Standard screw ²⁾	i	Stroke per drive shaft rotation ⁵⁾
GSZ-50-SN	Translating	Normal	Tr 40x7	7:1	1.00 mm
GSZ-50-SL	screw	Low speed		28:1	0.25 mm
GSZ-50-RN	Rotating	Normal	Tr 40x7	7:1	1.00 mm
GSZ-50-RL	screw	Low speed		28:1	0.25 mm

Screw jack mounting

- max. load: 50 kN compressive and tensile load
- Screw: M12, strength class 8.8
- Screw-in depth: 12 to 17 mm
- Tightening torque: 38 Nm
- Screw locking: with Loctite 243

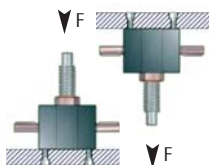

Duty cycle thermal limit, for S+R

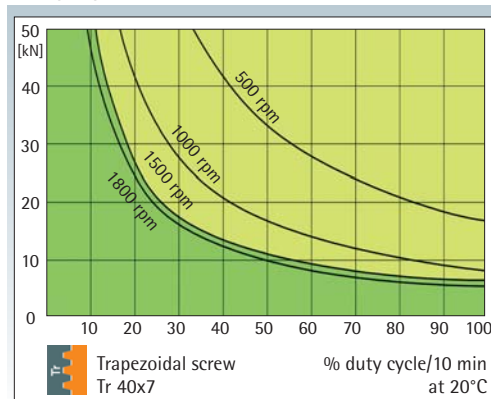

These curves are for guidance under standard industrial conditions (ambient temperature etc.) and correct maintenance (lubrication etc.). The max. input drive torques for optimum service life are at the right page - technical data (1500 rpm)

KGT:
% duty cycle
2 times to
4 times higher

Trapezoidal screw

Tr



GSZ-50-R rotating screw 50 kN

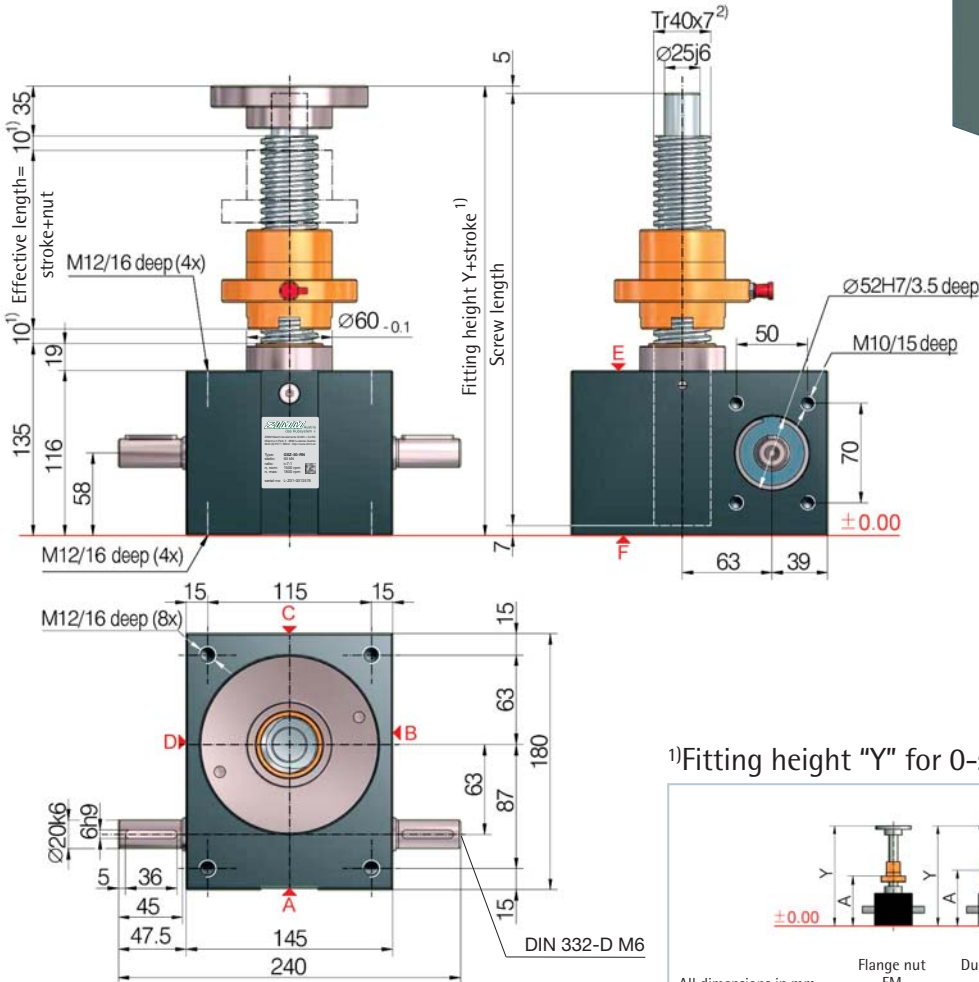
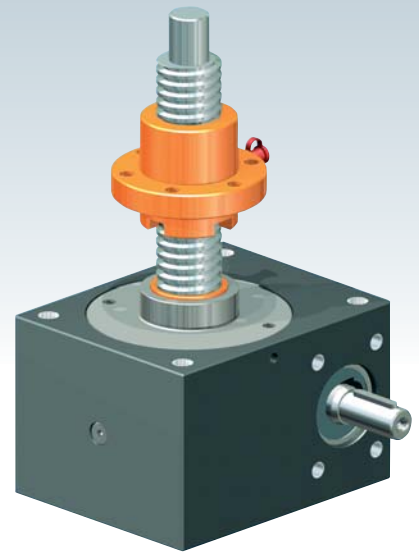

¹⁾Fitting height "Y" for 0-stroke, with Tr 40x7 screw

All dimensions in mm	Flange nut FM	Duplex nut DM	Duplex nut DM with SIFA	Self-aligning nut PM	Greasless nut FFDM
	Y/A	Y/A	Y/A	Y/A	Y/A
Bellows FB	256/161	260/179	323/242	319/244	275/195
without bellows FB	-	403/252	462/311	462/317	420/270
2x Z-50-FB-390	-	377/239	436/298	436/304	394/257
2x Z-50-FB-600	-	493/297	552/356	552/362	510/315
2x Z-50-FB-1000	-	483/292	542/351	542/357	500/310
2x Z-50-FB-1200	-	593/347	652/406	652/412	610/365
2x Z-50-FB-1500	-				

Detailed instructions for determining the length can be found in Section 8

50 kN

Technical data series GSZ-50-S / GSZ-50-R

max. compressive/tensile force, static	- 50 kN (5 t)
max. compressive/tensile force, dynamic	- see duty cycle curves
Nominal speed	- 1500 rpm
max. drive shaft speed	- 1800 rpm (depending on the load and duty cycle)
Screw size standard	- Tr 40x7 ²⁾
Gear ratio	- 7:1 (N) / 28:1 (L)
Housing material	- GGG-50, corrosion-resistant
Worm shaft	- steel, case-hardened, ground
Weight of screw jack body	- 15 kg
Weight of screw/m	- 8 kg
Gearbox lubrication	- synthetic fluid grease
Screw lubrication	- grease lubrication
Gearbox operating temperature	- max. 60°C, higher on request
Moment of inertia	- N: 6.40 kg cm ² / L: 2.53 kg cm ²
Input torque (at 1500 rpm)	- max. 31.5 Nm (N) / max. 10.4 Nm (L)
Drive-through torque	- max. 260 Nm

Drive torque M_0 (Nm)	- F (kN) \times 0.68 ³⁾⁵⁾ + M_L (N-normal)
Breakaway torque	- F (kN) \times 0.23 ³⁾⁵⁾ + M_L (L-low speed)
Idling torque ⁴⁾ M_L (Nm)	- Drive torque M_0 \times 1.5
	- 0.76 (N-normal) / 0.54 (L-low speed)

Between gearbox and nut or nut and end of thread, provide for a safety distance of (minimum) 10 mm!
See Section 7 for the checklist.

Important information

- 1) - extension if a bellows or spiral spring is fitted: see the table or Section 8
- 2) - Tr 40x7 is standard, also available: double-pitch, stainless steel, left-handed, increased screw Tr 55x9 (only for the R version)
- 3) - factor includes efficiency, ratio and 30% safety
- 4) - at 20°C, can be higher when new
- 5) - for a 7 mm screw pitch



UNIQUE:
Screw lubrication
during operation

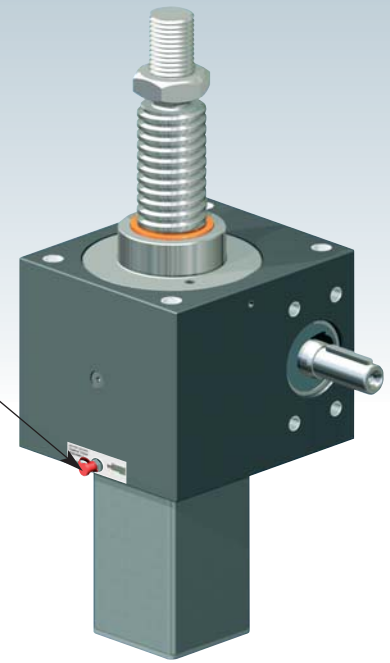

GSZ-100-S translating screw 100 kN

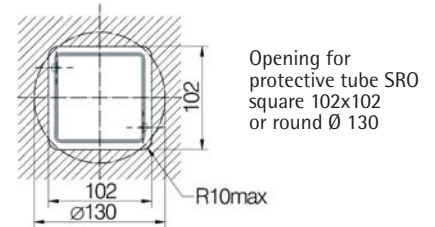
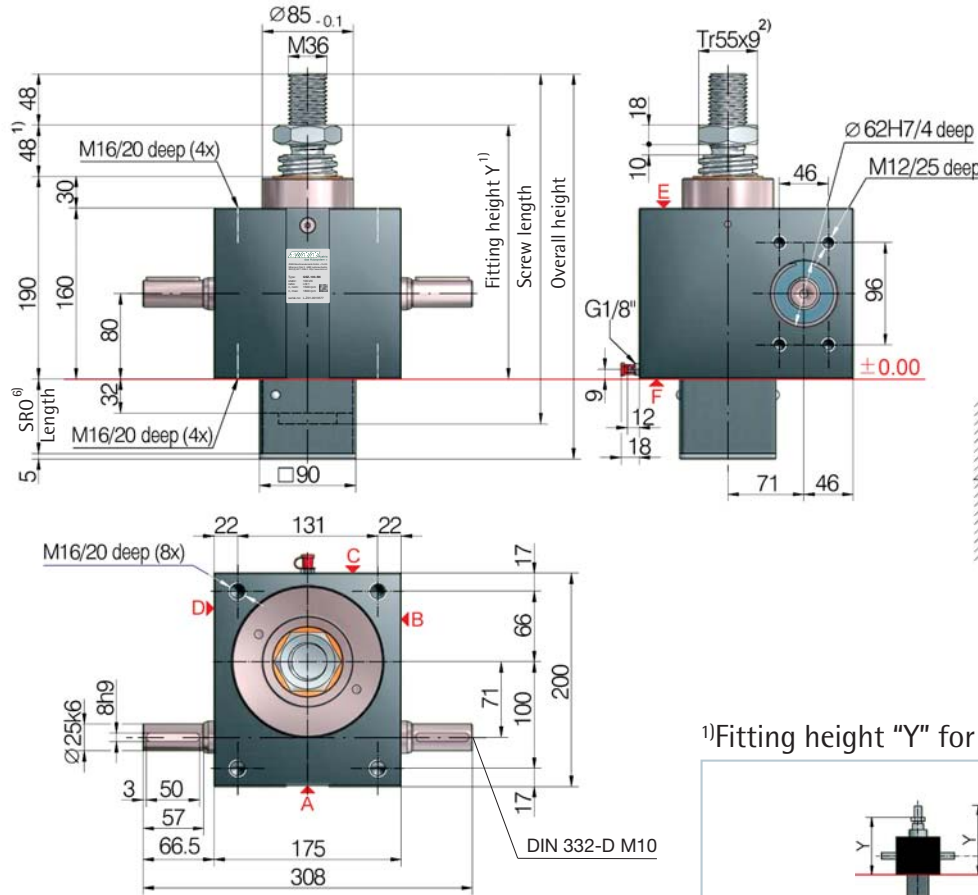

1) Fitting height "Y" for 0-stroke, with Tr 55x9 screw

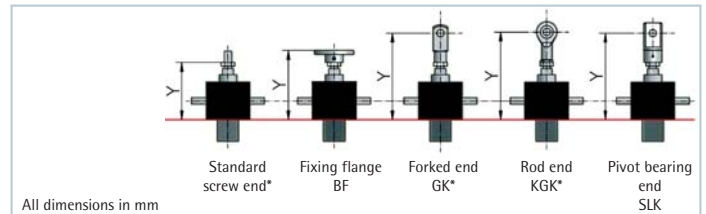

All dimensions in mm

Bellogs FB	Y	Y	Y	Y	Y
without bellogs FB	238	288	382	380	346
Z-100-FB-285	311	313	455	453	371
Z-100-FB-600	308	310	452	450	368
Z-100-FB-1000	366	368	510	508	426
Z-100-FB-1500	416	418	560	558	476

*with bellogs fixing ring Z-100-FBR

6) Protective tube length SRO with Tr 55x9 screw

Without escape/ rotation protection	Escape/ rotation protection	Rotation protection, with limit switch set ES	Rotation protection with ES and KAR*
82+stroke	112+stroke	144+stroke	189+stroke

*Hinged bearing plate KAR, fitted on face F (below)

Standard ratios

Type	Version	Speed	Standard screw ²⁾	i	Stroke per drive shaft rotation ⁵⁾
GSZ-100-SN	Translating	Normal	Tr 55x9	9:1	1.00 mm
GSZ-100-SL	screw	Low speed		36:1	0.25 mm
GSZ-100-RN	Rotating	Normal	Tr 55x9	9:1	1.00 mm
GSZ-100-RL	screw	Low speed		36:1	0.25 mm

Screw jack mounting

- max. load: 100 kN compressive and tensile load
- Screw: M16, strength class 8.8
- Screw-in depth: 16 to 22 mm
- Tightening torque: 82 Nm
- Screw locking: with Loctite 243

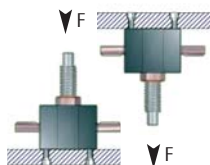

Duty cycle thermal limit, for S+R

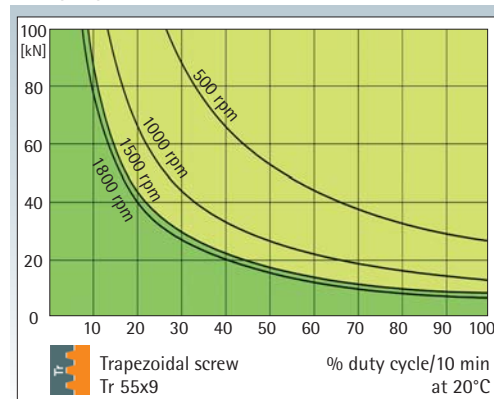

These curves are for guidance under standard industrial conditions (ambient temperature etc.) and correct maintenance (lubrication etc.). The max. input drive torques for optimum service life are at the right page - technical data (1500 rpm)

KGT:
% duty cycle
2 times to
4 times higher

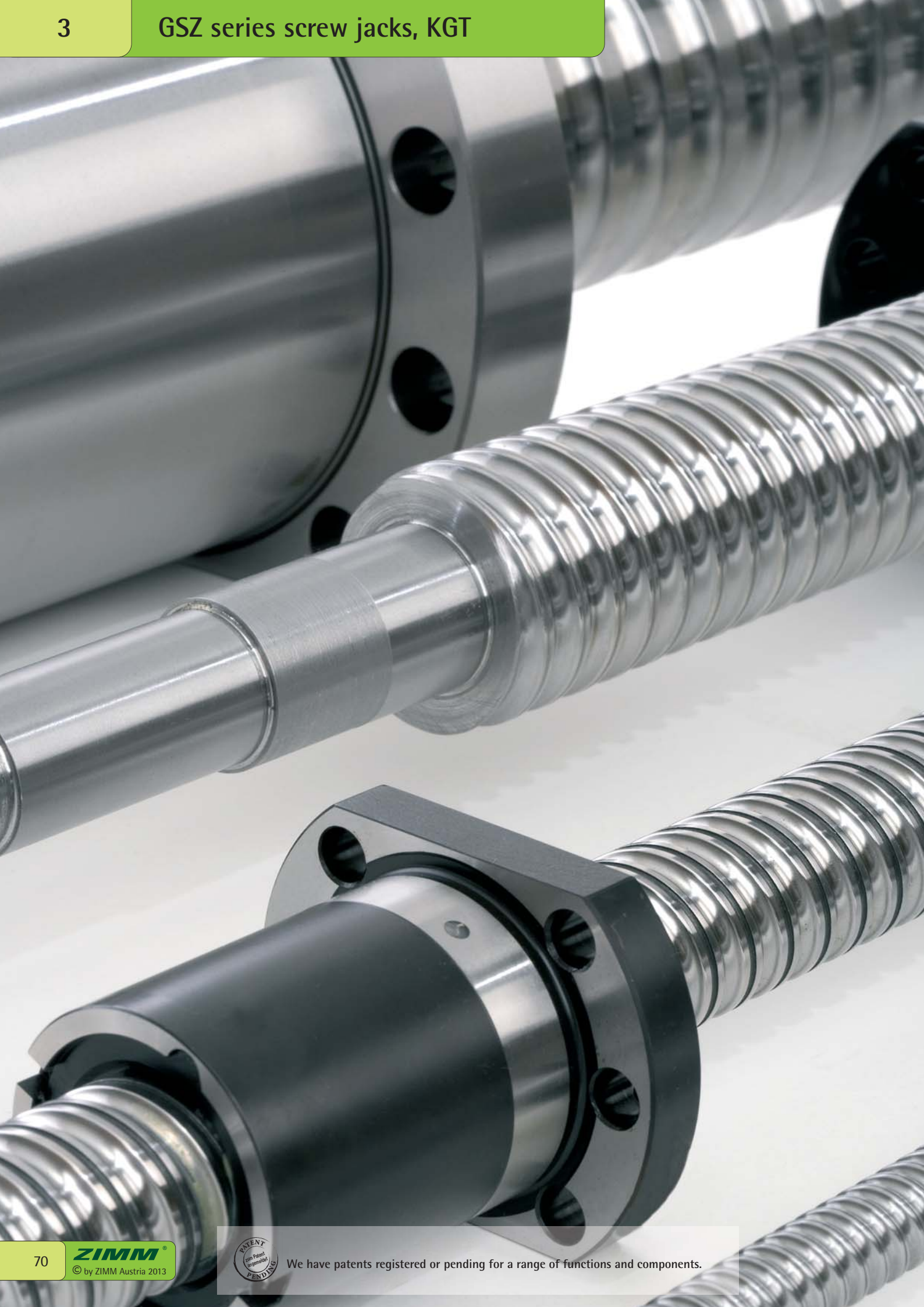

Ball screw KGT



Most screw jacks use trapezoidal screws Tr, because they are simple, robust and inexpensive. The proportion of screw jacks that use ball screws is however constantly increasing. The reasons for this are primarily their pitch accuracy, their high efficiency (less power consumption and less heat generation) and the higher pitches available, which permit higher stroke speeds.

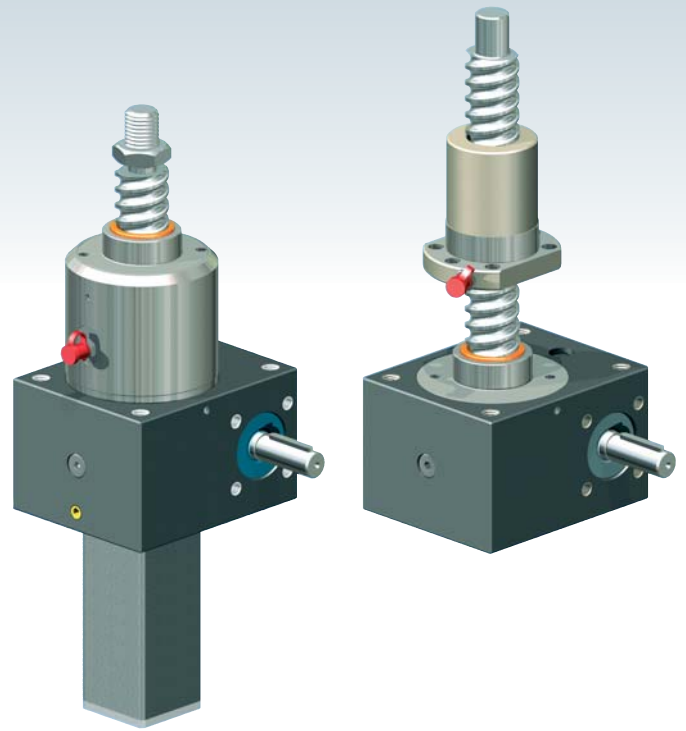

Technical data KGT

Pitch accuracy

0.05 mm / 300 mm

Material: 1.1213 (Cf 53), induction hardened and polished.

No self-locking!

Because of the lack of friction, a holding brake is necessary: a motor brake or a spring pressure brake is required.

Temperatures, duty cycle

Operating temperature range -25°C to + 80°C. The duty cycle can be up to 4 times higher than for trapezoidal screws (see diagrams), and at long strokes up to 2 times higher than for trapezoidal screws.

Service life

Heavy loads reduce the service life of the KGT. Tell us the load and stroke speed and we will calculate the service life.

Contamination

All nuts are fitted with scrapers. For heavy contamination and fine dust/chips, we recommend fitting bellows or a spiral spring cover.

Escape/rotation protection

Under no circumstances may the nut be screwed off the screw. We therefore always provide escape/rotation protection on the S version.

Start ramp / braking ramp

We recommend using a frequency converter or a soft start device, especially for high lead screw jacks. This allows regulation of the start ramp / braking ramp. This ensures protection for the entire system.

Safety clearance L3 can also be reduced at your own discretion, in particular for high pitches.

Grease nipples

The standard position of the grease nipple on the S version is on the gearbox face "C". Optionally, face A is available. Faces B and D are available on request.



We have patents registered or pending for a range of functions and components.



UNIQUE:
Ball screw lubrication
for the S version

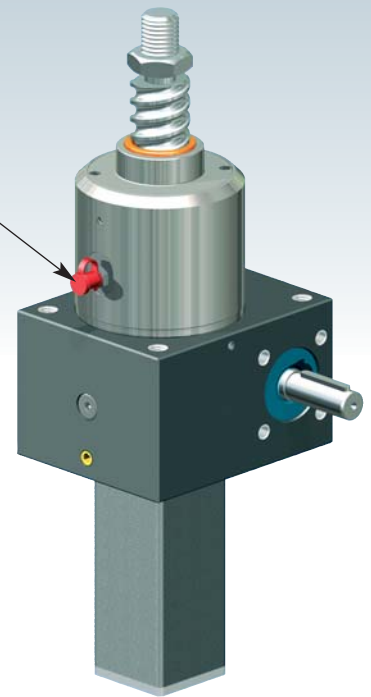

GSZ-5 to GSZ-100, KGT-S translating screw

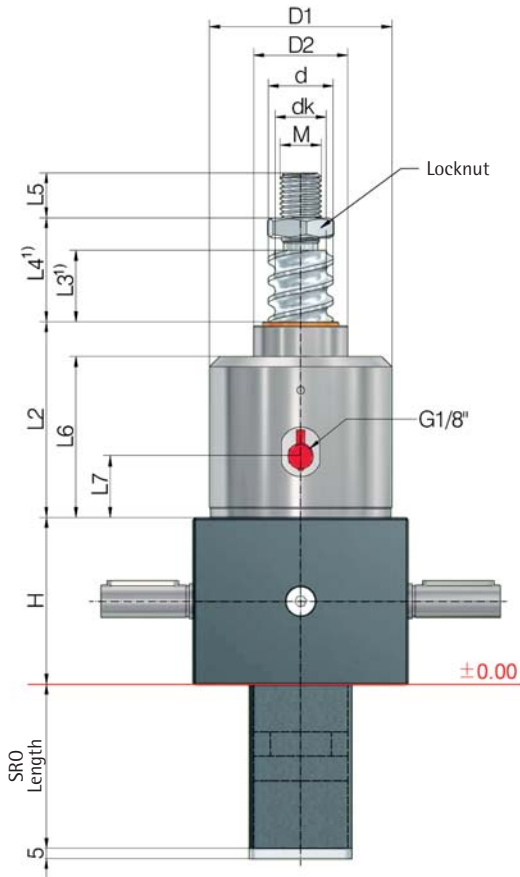

i - further technical information: Page 71
 - see the respective screw jack page for all other dimensions
 - see Section 4 for accessories
 - dimensions on the illustrative diagrams are in mm.
 We reserve the right to make changes.

🛒 **Ordering example:**
 GSZ-100-SN-KGT 50x20, C = 112.4 kN
 dynamic load rating C

Screw jacks	Ball screw KGT	Stroke per drive revolution [mm]		KGT load rating [kN]		Dimensions [mm]											Axial play max ⁵⁾ [mm]	
		SN	SL	dyn. C ²⁾	stat. C ₀ =C _{0a}	H	d	dk	D ₁	D ₂	L ₂	L ₃ ¹⁾	L ₄ ¹⁾	L ₅	L ₆	L ₇		M
GSZ-5	16x5	1.25	0.31	9.3	13.1	62	15.5	12.9	59	29	66	15	25	19	54	23	M12	0.08
	16x10	2.50	0.63	15.4	26.5	62	15.4	13.0	59	29	66	25	35	19	54	23	M12	0.08
GSZ-10	25x5	1.25	0.31	12.3	22.5	74	24.5	21.9	69	39	85	15	27	20	69	21	M14	0.08
	25x10	2.50	0.63	13.2	25.3	74	24.5	21.9	69	39	85	25	37	20	69	21	M14	0.08
	25x25	6.25	1.56	16.7	32.2	74	24.5	22.0	69	39	85	60	72	20	69	21	M14	0.08
	25x50	12.50	3.13	15.4	31.7	74	24.1	21.5	69	39	85	125	137	20	69	21	M14	0.15
GSZ-25	32x5	0.83	0.21	21.5	49.3	82	31.5	28.9	89	46	99	15	31	22	82	33	M20	0.08
	32x10	1.67	0.42	33.4	54.5	82	32.7	27.3	89	46	99	20	36	22	82	33	M20	0.08
	32x20	3.33	0.83	29.7	59.8	82	31.7	27.9	89	46	99	35	51	22	82	33	M20	0.08
	32x40	6.67	1.67	14.9	32.4	82	30.9	28.3	89	46	99	70	86	22	82	33	M20	0.08
GSZ-50	40x5	0.71	0.18	23.8	63.1	116	39.5	36.9	125	60	93	15	39	29	74	17	M30	0.08
	40x10	1.43	0.36	38	69.1	116	39.5	34.1	125	60	93	15	39	29	74	17	M30	0.08
	40x20	2.86	0.72	33.3	76.1	116	39.7	35.9	125	60	93	30	54	29	74	17	M30	0.08
	40x40	5.71	1.43	35	101.9	116	38.9	36.3	125	60	93	60	84	29	74	17	M30	0.08
GSZ-100	50x10	1.11	0.28	68.7	155.8	160	49.5	44.1	148	85	112	20	48	48	82	19	M36	0.08
	50x20	2.22	0.56	60	136.3	160	49.5	44.1	148	85	112	40	68	48	82	19	M36	0.08
	50x10	1.11	0.28	112.1	338.5	160	50	43.6	148	85	148	20	48	48	118	19	M36	0.03
	50x20	2.22	0.56	112.4	214.7	160	50	41.1	148	85	148	40	68	48	118	19	M36	0.03
	50x40	4.44	1.11	84.7	143.1	160	50	41.1	148	85	148	80	108	48	118	19	M36	0.03

¹⁾ Depending on the control system and drive, the dimensions L₃ and L₄ can be reduced at your own discretion.
 An extension may be required if a bellows or spiral spring is fitted

²⁾ Dynamic load rating to DIN 69051 part 4 draft 1989.

⁵⁾ Reduced play 0.02 mm available on request.

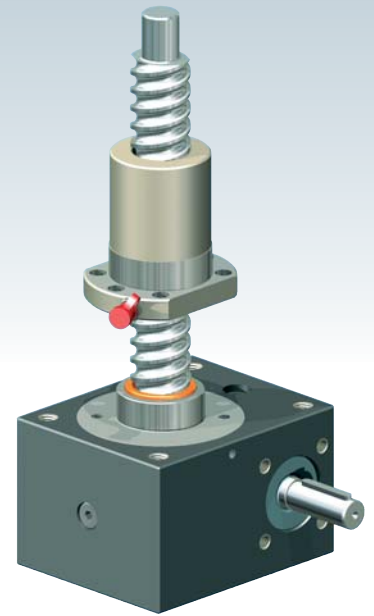

GSZ-2 to GSZ-100, KGT-R rotating screw

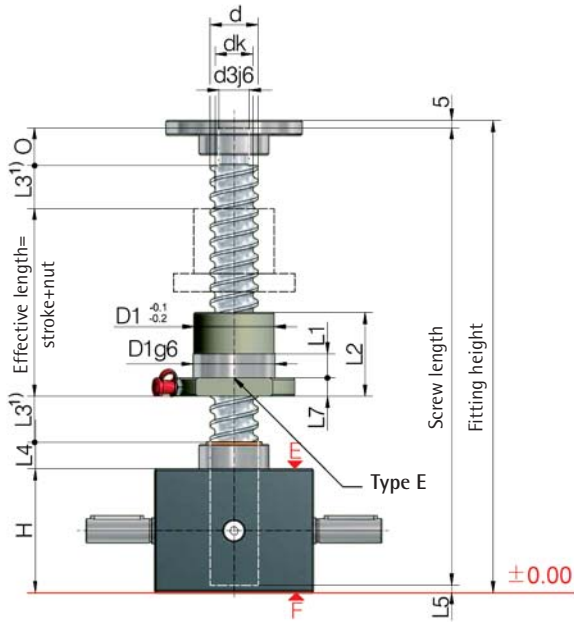

Position of the flange nut:
G = flange gearbox side
(as shown)
S = flange screw side

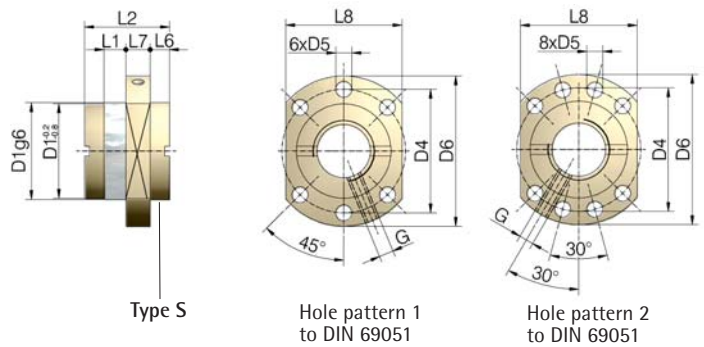

Adapter for KGT
Dimension sheet on request

An increased screw (such as Z-10-RN with screw 32x10) can also be used for the rotating version.

Ordering example:
GSZ-100-RN-KGT 50x20, C = 112.4 kN - G
dynamic load rating C
Nut flange
G: flange gearbox side
S: flange screw side

Screw jacks	Ball screw KGT	Stroke per drive revolution [mm]		KGT load rating [kN]		Nut Type	Nut Hole pattern	Dimensions [mm]																	Lubrication hole	Axial play max ⁵⁾ [mm]
		RN	RL	dyn. C ²⁾	stat. C ₀ =C _{0a}			d	dk	ds	O	H	D ₁	D ₄	D ₅	D ₆	L ₁	L ₂	L ₃ ¹⁾	L ₄	L ₅	L ₆	L ₇	L ₈		
GSZ-2	16x5	1.25	0.31	9.3	13.1	E 1	1	15.5	12.9	10	12	50	28	38	5.5	48	10	42	15	11	3	-	10	40	M6	0.08
	16x10	2.50	0.63	15.4	26.5	E 1	1	15.4	13.0	10	12	50	28	38	5.5	48	10	55	25	11	3	-	10	40	M6	0.08
GSZ-5	16x5	1.25	0.31	9.3	13.1	E 1	1	15.5	12.9	12	15	62	28	38	5.5	48	10	42	15	12	8	-	10	40	M6	0.08
	16x10	2.50	0.63	15.4	26.5	E 1	1	15.4	13.0	12	15	62	28	38	5.5	48	10	55	25	12	8	-	10	40	M6	0.08
GSZ-10	25x5	1.25	0.31	12.3	22.5	E 1	1	24.5	21.9	15	20	74	40	51	6.6	62	10	42	15	16	8	-	10	48	M6	0.08
	25x10	2.50	0.63	13.2	25.3	E 1	1	24.5	21.9	15	20	74	40	51	6.6	62	16	55	25	16	8	-	10	48	M6	0.08
	25x25 ³⁾	6.25	1.56	16.7	32.2	S 1	1	24.5	22.0	15	20	74	40	51	6.6	62	9	35	60	16	8	8	10	- ³⁾	M6	0.08
	25x50	12.50	3.14	15.4	31.7	S 1	1	24.1	21.5	15	20	74	40	51	6.6	62	10	58	125	16	8	10	10	48	M6	0.15
GSZ-25	32x5	0.83	0.21	21.5	49.3	E 1	1	31.5	28.9	20	25	82	50	65	9.0	80	10	55	15	17	5	-	12	62	M6	0.08
	32x10	1.67	0.42	33.4	54.5	E 1	1	32.7	27.3	20	25	82	53 ⁴⁾	65	9.0	80	16	69	20	17	5	-	12	62	M8x1	0.08
	32x20	3.33	0.83	29.7	59.8	E 1	1	31.7	27.9	20	25	82	53 ⁴⁾	65	9.0	80	16	80	35	17	5	-	12	62	M6	0.08
	32x40 ³⁾	6.67	1.67	14.9	32.4	S N ⁴⁾	1	30.9	28.3	20	25	82	53 ⁴⁾	68 ⁴⁾	7.0 ⁴⁾	80	14	45	70	17	5	7.5	16	- ³⁾	M6	0.08
GSZ-50	40x5	0.71	0.18	23.8	63.1	E 2	2	39.5	36.9	25	30	116	63	78	9	93	10	57	15	19	7	-	14	70	M6	0.08
	40x10	1.43	0.36	38	69.1	E 2	2	39.5	34.1	25	30	116	63	78	9	93	16	71	15	19	7	-	14	70	M8x1	0.08
	40x20	2.86	0.72	33.3	76.1	E 2	2	39.7	35.9	25	30	116	63	78	9	93	16	80	30	19	7	-	14	70	M8x1	0.08
	40x40	5.71	1.43	35	101.9	S 2	2	38.9	36.3	25	30	116	63	78	9	93	16	85	60	19	7	7.5	14	- ³⁾	M8x1	0.08
GSZ-100	50x10	1.11	0.28	68.7	155.8	E 2	2	49.5	44.1	40	45	160	75	93	11	110	16	95	20	30	8	-	16	85	M8x1	0.08
	50x20	2.22	0.56	60	136.3	E 2	2	49.5	44.1	40	45	160	85 ⁴⁾	103 ⁴⁾	11	125 ⁴⁾	22	95	40	30	8	-	18	95	M8x1	0.08
	50x10	1.11	0.28	112.1	338.5	E 2	2	50	43.6	40	45	160	75	93	11	110	16	107	20	30	8	-	16	85	M8x1	0.03
	50x20	2.22	0.56	112.4	214.7	E 2	2	50	41.1	40	45	160	85 ⁴⁾	103 ⁴⁾	11	120 ⁴⁾	16	125	40	30	8	-	16	95	M8x1	0.03
	50x40	4.44	1.11	84.7	143.1	E 2	2	50	41.1	40	45	160	85 ⁴⁾	103 ⁴⁾	11	120 ⁴⁾	16	125	80	30	8	-	16	95	M8x1	0.03
50x50 ⁴⁾	5.56	1.39	84.7	143.1	E 2	2	50	41.1	40	45	160	85 ⁴⁾	103 ⁴⁾	11	120 ⁴⁾	16	145	100	30	8	-	16	95	M8x1	0.03	

¹⁾ An extension may be required if a bellows or spiral spring is fitted.
²⁾ Dynamic load rating to DIN 69051 part 4 draft 1989.
³⁾ Round flange.

⁴⁾ Non-preferred design.
⁵⁾ Reduced play 0.02 mm available on request.
⁶⁾ Not to DIN 69051.



Safety nut SIFA



Function

A safety nut is designed for use where stripping and break up of the thread could cause a hazard to persons.

A safety nut can also provide protection for other equipment against the consequences of machine failures and downtimes.

Wear

Once the wear exceeds max. 25% of the screw pitch, the load nut (R) or the gearbox (S) must be replaced.

Monitoring

Wear and thread play should be checked and documented at regular intervals (depending on the duty cycle).

This allows the fitting of replacement parts to be planned ahead, reducing unscheduled system downtime.

Electrical monitoring

Electrical monitoring gives a signal when wear reaches approx. 25%. This signal can be displayed immediately at a central control point. Replacement of the worn parts can then be scheduled.

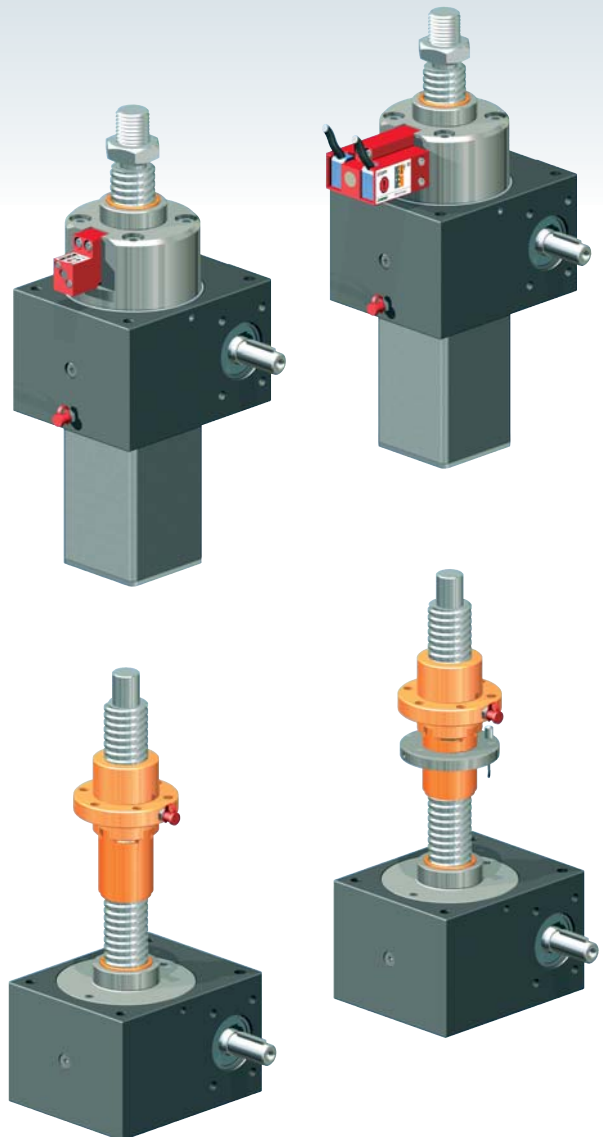

Screw jacks	Pitch P	max. permissible wear/ thread play* (25% of P)
[TrØxP]	[mm]	[mm]
Tr16x4, Tr18x4, Tr20x4	4	1.0
Tr30x6	6	1.5
Tr40x7	7	1.75
Tr 55x9	9	2.25

* Identical for double pitch screws (same thread flank thickness)

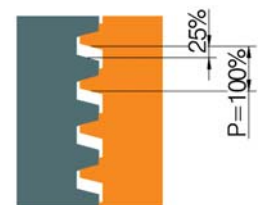

max. 25% wear



We have patents registered or pending for a range of functions and components.



SIFA-S translating screw

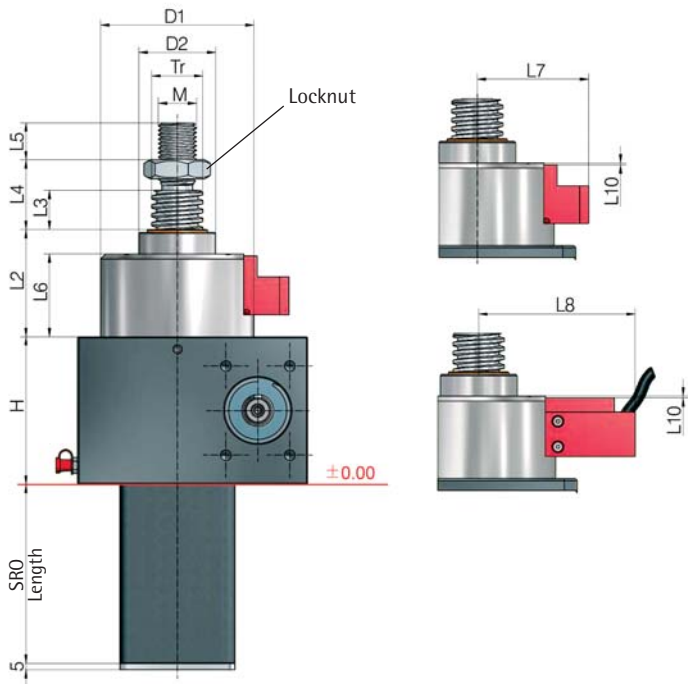
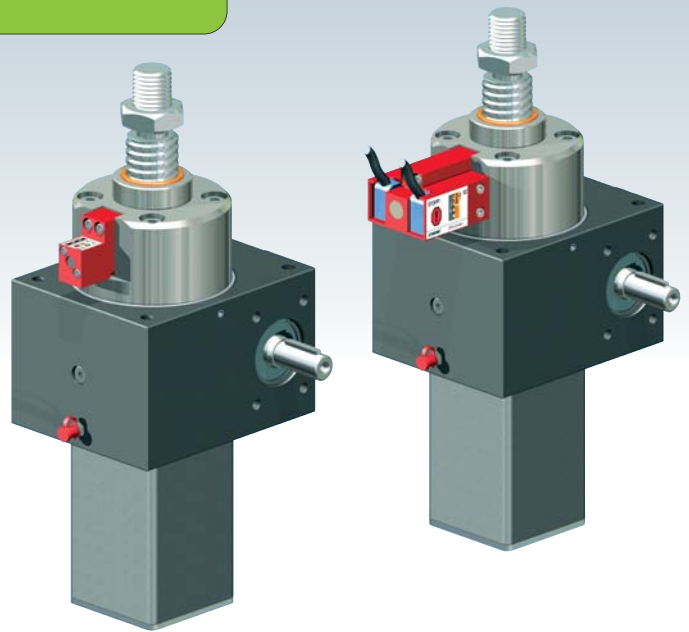

Function S version



The load is borne by the worm wheel via the screw. If the worm wheel screw thread wears through, the SIFA restrains the screw. The load remains supported.

Direction of loading, compressive and tensile
The new SIFA-S operates equally in both compressive and tensile directions of loading!

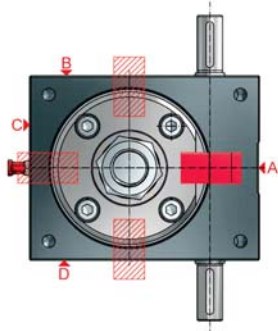

Ordering code:

GSZ-50-SN-SIFA-OP-A

Version
SN or SL
Monitoring
OP: visual
EL: electrical (wear, thread stripping)
ELV: only wear
ELD: only thread stripping
NO: without any monitoring
Position
A (standard), B, C or D
(can also subsequently be rotated steplessly through 360°)

i further technical information: Page 75

Screw jack	Stroke travel/rev.		Tr thread	H	D1	D2	L2	L3 ¹⁾	L4 ¹⁾	L5	L6	L7	L8	L9	L10	M
	SN	SL														
GSZ-10	1	0.25	20x4	74	81	39	74	10	22	20	58	72	108	21	1	M14
GSZ-25	1	0.25	30x6	82	92	46	76	10	26	22	59	79	114	25	1	M20
GSZ-50	1	0.25	40x7	116	120	60	84	10	34	29	65	88	123	58	1	M30
GSZ-100	1	0.25	55x9	160	135	85	103	20	48	48	73	95	130	80	9	M36

¹⁾ See Section 8 for extension if bellows or spiral spring is fitted

SIFA-S, monitoring

Visual

Monitoring

Wear should be checked and documented at regular intervals. This allows the fitting operation for replacement to be planned in good time so as to avoid system downtime.

OK

Wear still <25% of P

CAUTION!

max. permissible wear reached –
Replace the gearbox

STOP!

Wear >25% or thread already worn through –
Stop operation immediately!

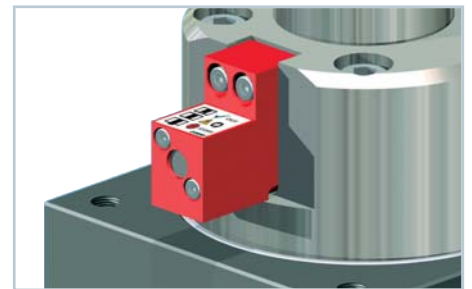
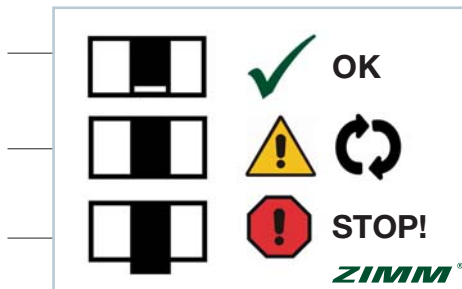

Electrical

WARNING! Switch S1

At 25% wear the limit switch S1 trips. The customer must detect this signal. This enables substitution to be planned well in advance and therefore prevents any unnecessary downtime.

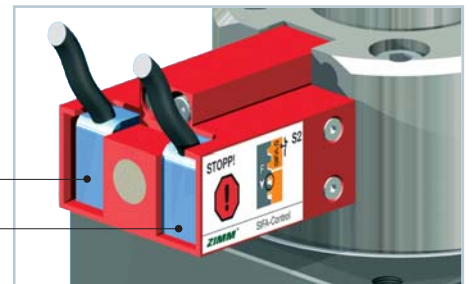

STOP! Switch S2

If after the first signal operation of the jack continues, the nut will continue to wear until the thread is worn through. When the thread is worn through, the safety nut takes the load. The limit switch S2 trips. The customer must detect this signal and stop the system.

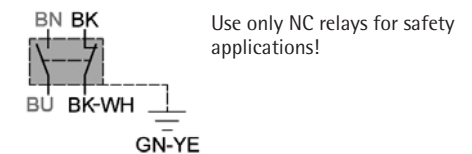

Without any monitoring

If the version used has no monitoring, the dimension A must be measured and documented when new, then regularly checked and documented.

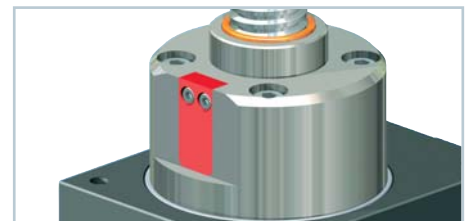
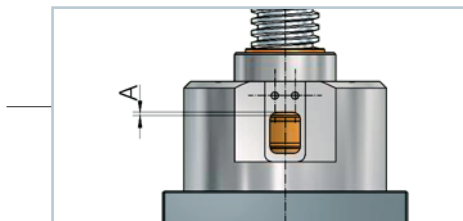



SIFA-R rotating screw

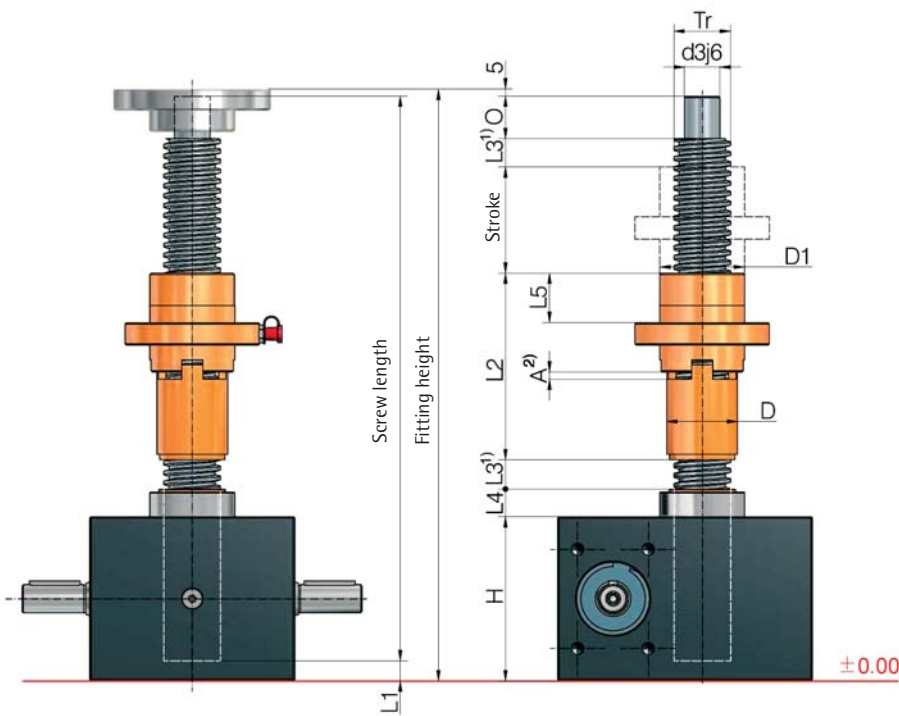
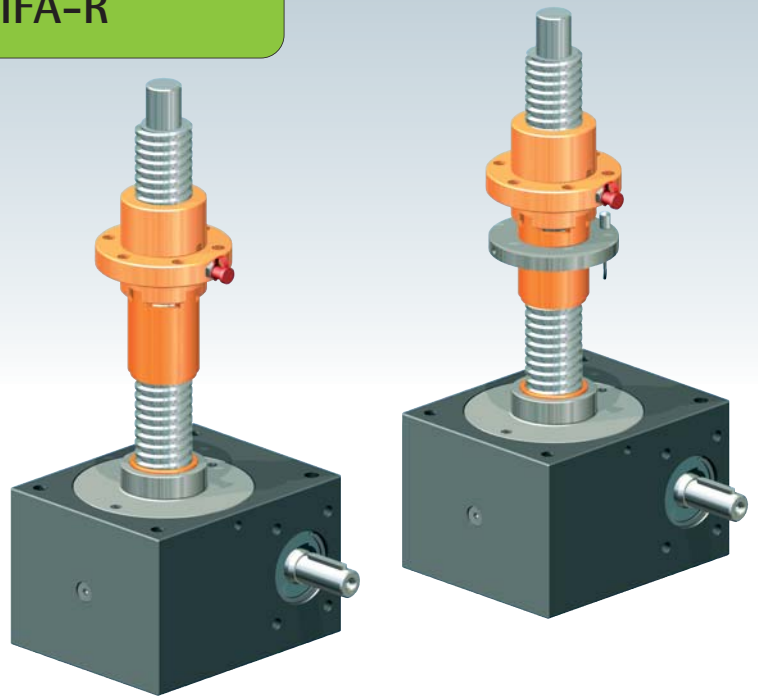

Function R version



The load is borne by the duplex nut. The safety nut runs alongside the duplex nut, bearing no load. If the nut thread is worn through due to wear, the SIFA takes the load on the duplex nut.

Direction of loading, compressive or tensile
A drawing showing the direction of loading is necessary in order to ensure the safety function. The SIFA-R operates in only one direction of loading.

- further technical information: Page 75
- see the respective screw jack page for all other dimensions
- see Section 4 for accessories
- SIFA in combination with self-aligning nut PM available on request

Screw jacks	Tr thread	H	D1	D	d3j6	O	L1	L2	L3 ¹⁾	L4	L5	A ²⁾
GSZ-2	16x4	50	26	22	10	12	3	70	10	11	20	3
GSZ-5	18x4	62	29	24	12	15	8	70	10	12	20	3
GSZ-10	20x4	74	39	28	15	20	8	84	10	16	20	3
GSZ-25	30x6	82	46	38	20	25	5	95	10	17	23	4
GSZ-50	40x7	116	60	50	25	30	13	133	10	19	36	4
GSZ-100	55x9	160	85	65	40	45	10	173	20	30	54	6

Make sure you fit it the right way up:

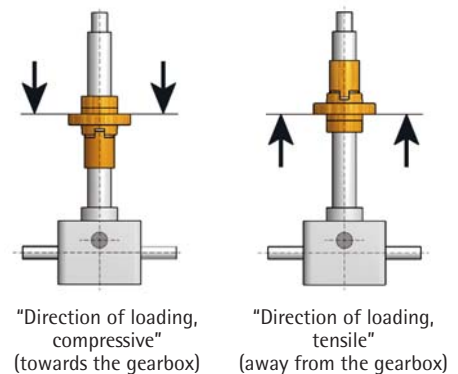

¹⁾ See Section 8 for extension if bellows or spiral spring is fitted
²⁾ approx. original setting, must be measured and documented by the customer, and referred to when checking

SIFA-R, monitoring

Visual

Dimension A is approx. the original setting. Dimension A must be measured and documented by the customer, and referred to when checking. This enables substitution to be planned well in advance and therefore prevents any unnecessary downtime. When the thread is worn through, take the equipment out of service immediately.

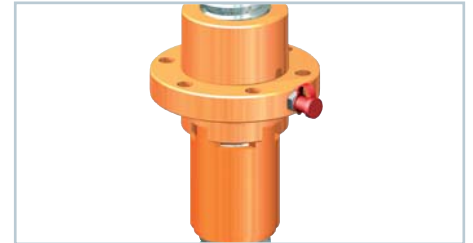
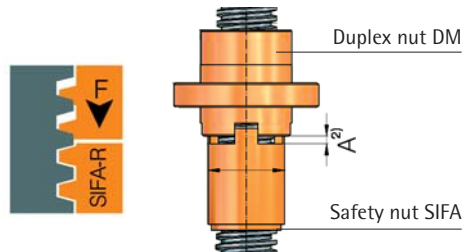

Electrical

The initiator must be set that it switches off when the load nut reaches 25% of the wear. This enables a replacement to be planned well in advance and therefore prevents any unnecessary downtime. When the thread is worn through, take the system out of service immediately.

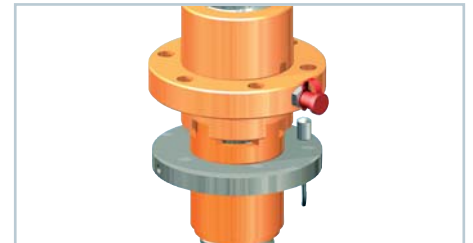
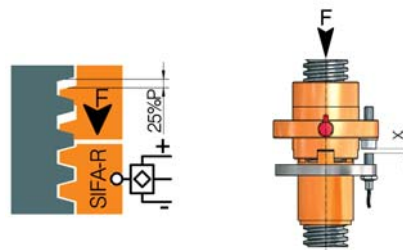

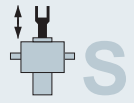

For the translating version S



Trapezoidal screws
S-Tr
Page 82



Fixing flange
BF
Page 82

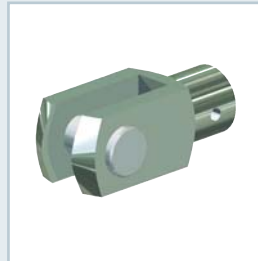

Forked end
GK
Page 82



Rod end
KGK
Page 82

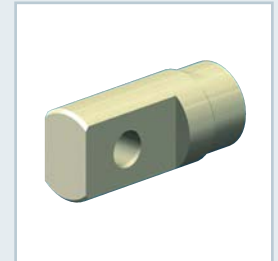

Pivot bearing end
SLK
Page 83

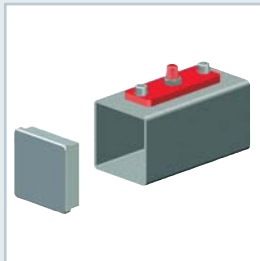

Protective tube
SRO
Page 83

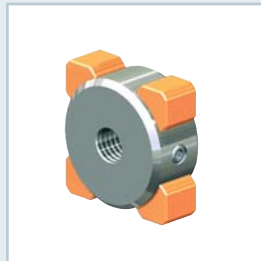

Rotation protection
VS
Page 83

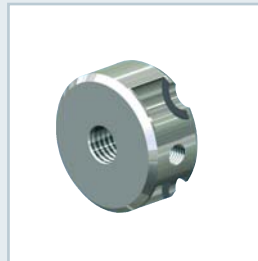

Escape protection
AS
Page 83

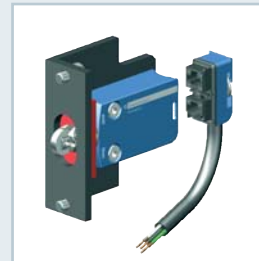

Limit switch set
ES
Page 84

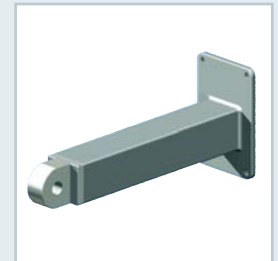

Pivoting support tube
STRO
Page 86

For the rotating version R

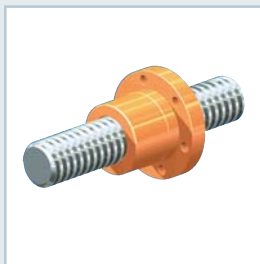
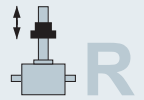

Flange nut
FM
Page 88

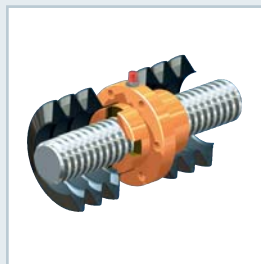

Duplex nut
DM
Page 89

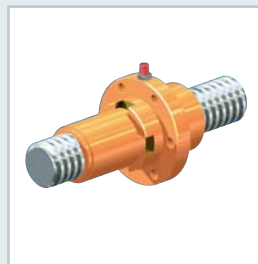

Safety nut
SIFA
Page 89



Cardan adapter
DMA for DM
Page 89



Driving flange
TRMFL for FM
Page 89

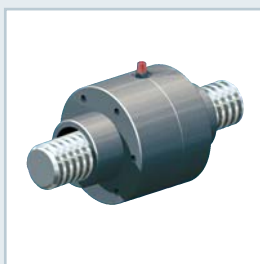

Self-aligning nut
PM
Page 90

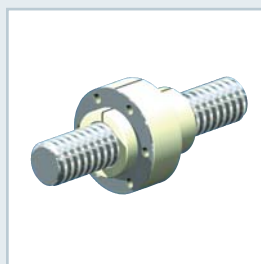

Greaseless nut
FFDM
Page 90

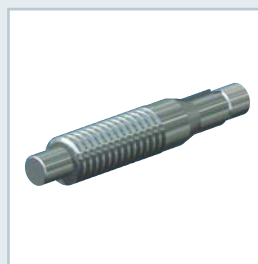

Trapezoidal screw
R-Tr
Page 91



Opposed bearing plate
GLP
Page 91

NOTE:
the accessories are suitable for Z and GSZ screw jacks. See also the overview on pages 6 and 7.

For S and R versions

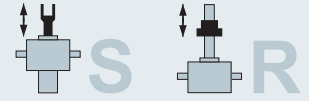

Bellows
FB
Page 92

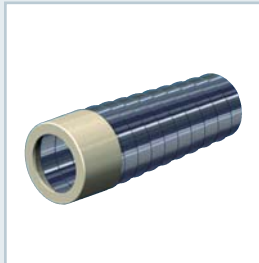

Spiral spring
SF
Page 94



Pivot mounts
LB
Page 96

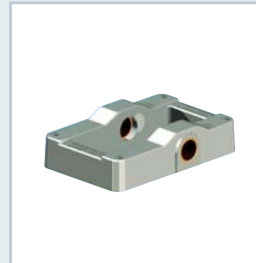

Pivot bearing plate
KAR
Page 96

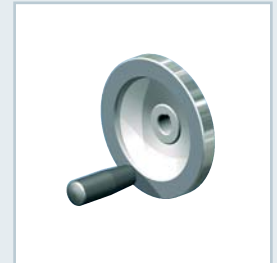

Handwheel
HR
Page 98



Protective cap
SK
Page 98



Fixing strips
BFL
Page 99



Pivot bearing plate
KAR
Page 99



Connecting shaft
VWZ
Page 100

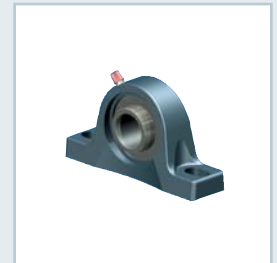

Pedestal bearing
STL
Page 103

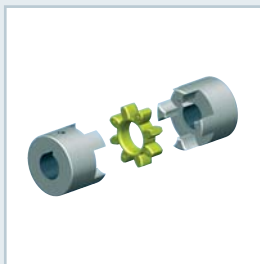

Standard coupling
KUZ
Page 104

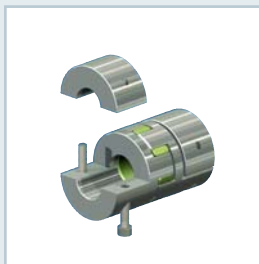

Clamp coupling
KUZ-KK
Page 105



Motor flange
MF
Page 106

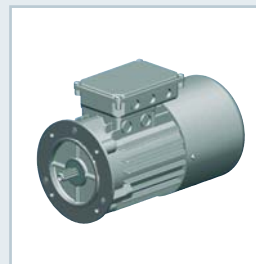

Three-phase AC motor
AC
Page 110



DC motor
DC
Page 111



Rotary pulse encoder
DIG
Page 116



Spring pressure brake
FDB
Page 118



Lubricants
Page 120



Lubricator
Z-LUB
Page 120



We have patents registered or pending for a range of functions and components.

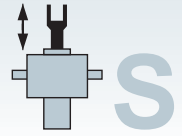

For the translating version S

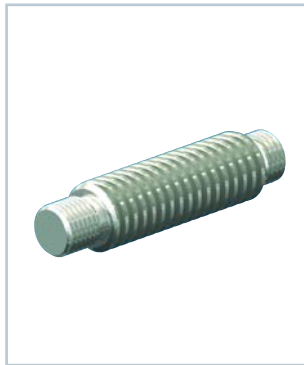

Trapezoidal screw Z-...-S-Tr

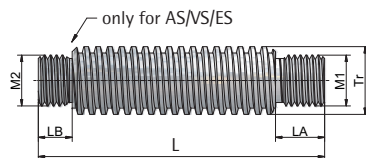

Material: St 60, C35, C45 (stainless steel), double-pitch, left-handed, on request, quality 7e DIN 103, pitch accuracy 0.2 mm/300 mm
Rolled as standard, from Tr 80 whirled

Part no.	Tr	M1	LA	M2	LB	kg/m
GSZ-2-S-Tr	Tr 16x4	M10	24	M10	15	1.2
Z-5-S-Tr	Tr 18x4	M12	29	M12	15	1.6
Z-10-S-Tr	Tr 20x4	M14	32	M14	20	2.0
Z-25-S-Tr	Tr 30x6	M20	38	M20	20	4.5
Z-35-S-Tr	Tr 40x7	M30	53	M24	30	8.0
Z-50-S-Tr	Tr 40x7	M30	53	M30	30	8.0
Z-50/Tr50-S-Tr	Tr 50x8	M36	76	M36	30	13
Z-100-S-Tr	Tr 55x9	M36	76	M36	30	16
Z-150-S-Tr	Tr 60x9	M42x2	48	M48x2	30	19
Z-250-S-Tr	Tr 80x16	M56x2	58	M64x3	30	32
Z-350-S-Tr	Tr 100x16	M72x3	78	M72x3	35	52
Z-500-S-Tr	Tr 120x16	M100x3	118	M85x3	40	77
Z-750-S-Tr	Tr 140x20	M110x3	130	M100x3	40	105
Z-1000-S-Tr	Tr 160x20	M110x3	130	M100x3	40	139

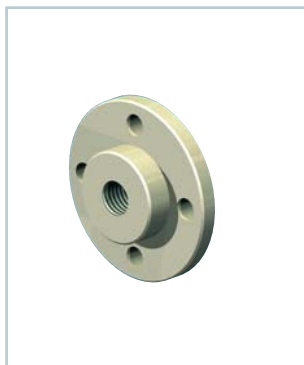

Fixing flange BF

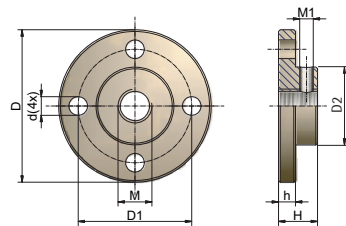

Part no.	D	D1	D2	M	d	h	H	M1	kg
GSZ-2-BF	50	40	26	M10	5.5	6	16	5	0.04
Z-5-BF	65	48	29	M12	9	7	20	5	0.21
Z-10-BF	80	60	38	M14	11	8	21	6	0.38
Z-25-BF	90	67	46	M20	11	10	23	8	0.57
Z-35/50-BF	110	85	60	M30	13	15	30	8	1.20
Z-100-BF	150	117	85	M36	17	20	50	10	3.50
Z-150-BF	170	130	90	M42x2	21	25	50	10	4.70
Z-250-BF	210	165	120	M56x2	26	30	60	12	9.50
Z-350-BF	260	205	145	M72x3	32	40	80	16	18.4
Z-500-BF	310	240	170	M100x3	38	40	120	16	30.0
Z-750-BF	340	265	200	M110x3	38	50	132	20	36.0

Material: steel, corrosion-resistant; aluminium, hard anodised (GSZ-2-BF)
identical to the previous MSZ type

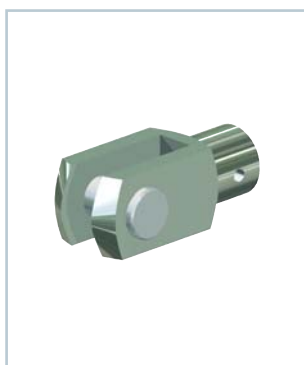

Forked end GK

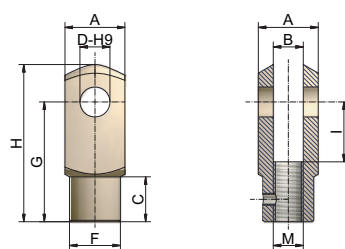

Part no.	A	B	C	D	M	F	G	H	I	kg
GSZ-2-GK	20	10	15	10	M10	18	40	52	20	0.10
Z-5-GK	24	12	18	12	M12	20	48	62	24	0.16
Z-10-GK	27	14	22	14	M14	24	56	72	28	0.24
Z-25-GK	40	20	30	20	M20	34	80	105	40	0.71
Z-35/50-GK	60	30	42	30	M30	52	120	160	60	2.48
Z-100-GK	70	36	54	35	M36	60	144	188	72	3.70
Z-150-GK	85	42	63	42	M42x2	70	168	232	84	5.30

Material: steel, galvanised (stainless steel on request)
incl. bolt and cotter pin
identical to the previous MSZ type



Rod end KGK

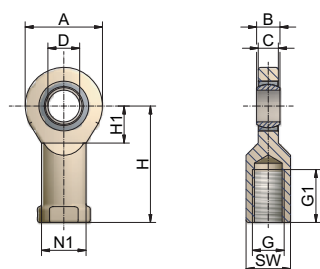

Part no.	A	B	C	D	G	G1	H	H1	SW	N1	kg
GSZ-2-KGK	31	14	12	10	M10	19	43	15	16	15	0.11
Z-5-KGK*	34	10	8	12	M12	23	50	17.5	18	17	0.10
Z-10-KGK*	40	12	10	15	M14	30	61	20	21	20	0.16
Z-25-KGK*	53	16	13	20	M20	40	77	27.5	32	27.5	0.32
Z-35/50-KGK*	73	22	19	30	M30	56	110	37	41	40	1.00
Z-100-KGK	92	28	24	40	M36	65	142	46	60	52	1.90
Z-150-KGK*	112	35	31	50	M42x2	68	160	56	70	62	3.60
Z-250-KGK	160	49	43	70	M56x2	80	200	80	85	80	8.30

CAUTION: Use only with rotation protection
Material: steel/steel, galvanised; steel/PTFE for GSZ-2-KGK (stainless steel on request)
*identical to the previous MSZ type

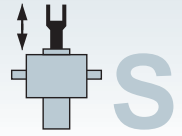

For the translating version S

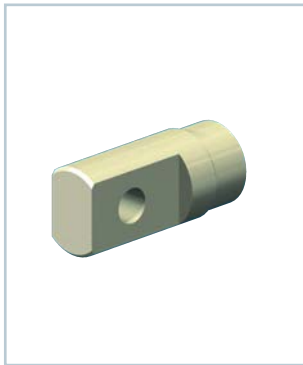

Pivot bearing end SLK

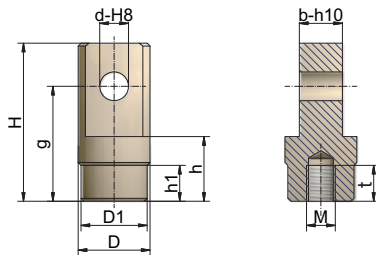

Part no.	H	D	D1	d	M	g	b	h	h1	t	kg
Z-5-SLK	65	30	29	12	M12	48	18	25	20	22	0.25
Z-10-SLK	80	40	39	14	M14	56	24	25	20	25	0.56
Z-25-SLK	110	50	46	20	M20	80	30	45	25	25	1.20
Z-35/50-SLK	130	65	60	30	M30	92	35	50	-	33	2.10
Z-100-SLK	144	90	85	35	M36	108	40	65	-	55	4.40
Z-150-SLK	210	100	90	50	M42x2	155	57	90	50	70	8.00
Z-250-SLK	260	125	120	80	M56x2	180	80	85	40	63	16.00
Z-350-SLK	280	145	145	95	M72x3	195	100	105	-	83	24.00
Z-500-SLK	335	170	170	110	M100x3	245	120	155	80	120	38.00

Material: steel, corrosion-resistant
identical to the previous MSZ type

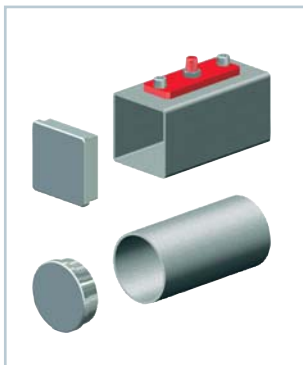

Protective tube SRO with cover

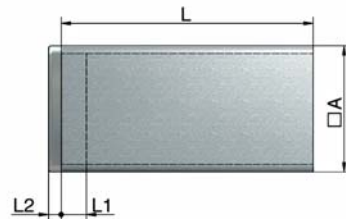

Material: Steel, powder-coated;
Aluminium, black anodised
(GSZ-2-SRO)

Cover: Aluminium, corrosion-resistant;
PE, black (GSZ-2)

Part no.	A	L1	L2	kg/m
GSZ-2-SRO	35x25	14	5	0.6
Z-5-SRO	35	10	5	2.1
Z-10-SRO	50	10	5	3.1
Z-25-SRO	50	10	5	3.1
Z-35-SRO	60	10	5	3.8
Z-50-SRO	90	10	5	8.2
Z-100-SRO	90	10	5	8.2
Z-150-SRO	120	10	5	11.5
Z-250-SRO	Ø125 / 120	10	5	7.6 / 11.5
Z-350-SRO	Ø150 / 160	15	5	19.0 / 19.3
Z-500-SRO	Ø180 / 180	15	5	22.0 / 27.0
Z-750-SRO	Ø210 / 200	15	5	26.0 / 30.0
Z-1000-SRO	Ø260 / 220	15	5	32.0 / 39.0

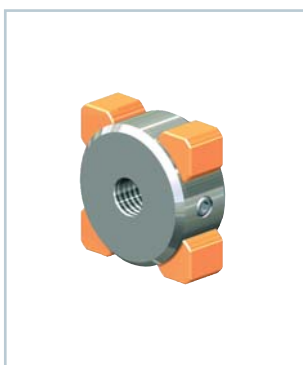

Rotation protection VS

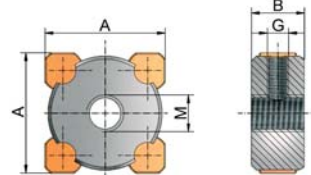

Material: *Steel, bronze
Rotation protection is required if the screw is
not fixed to the load so that it cannot rotate,
or is installed in combination with limit
switches or the rod end KGK.

Part no.	A	B	G	M	kg
GSZ-2-VS*	31x21	15	Ø3	M10	0.01
Z-5-VS*	31	15	M6	M12	0.10
Z-10-VS	46	20	M8	M14	0.23
Z-25-VS	46	20	M8	M20	0.23
Z-35-VS	56	30	M8	M24	0.65
Z-50-VS	84	30	M10	M30	1.27
Z-100-VS	84	30	M10	M36	1.20
Z-150-VS	114	30	M12	M48x2	2.15
Z-250-VS	114	30	M12	M64x3	2.15
Z-350-VS	152	35	M16	M72x3	4.6
Z-500-VS	170	40	M16	M85x3	6.6
Z-750-VS	190	40	M16	M100x3	8.0
Z-1000-VS	208	40	M16	M100x3	10.2

*for Z-5 the rotation protection is of solid bronze; GSZ-2 POM



Escape protection AS

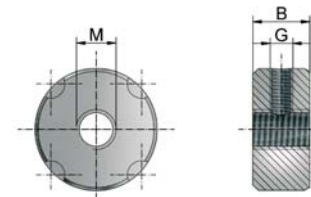

Material: Steel
Escape protection prevents the screw being
wound out of the gearbox. It is particularly
recommended for ball screws. Do not rely on
it as an operating travel stop.

Part no.	B	G	M	kg
GSZ-2-AS	15	M5	M10	0.01
Z-5-AS	15	M6	M12	0.05
Z-10-AS	20	M8	M14	0.16
Z-25-AS	20	M8	M20	0.14
Z-35-AS	30	M8	M24	0.40
Z-50-AS	30	M10	M30	0.80
Z-100-AS	30	M10	M36	0.74
Z-150-AS	30	M12	M48x2	1.48
Z-250-AS	30	M12	M64x3	1.17
Z-350-AS	35	M16	M72x3	2.87
Z-500-AS	40	M16	M85x3	3.86
Z-750-AS	40	M16	M100x3	6.00
Z-1000-AS	40	M16	M100x3	9.60

Limit switch set

Product features

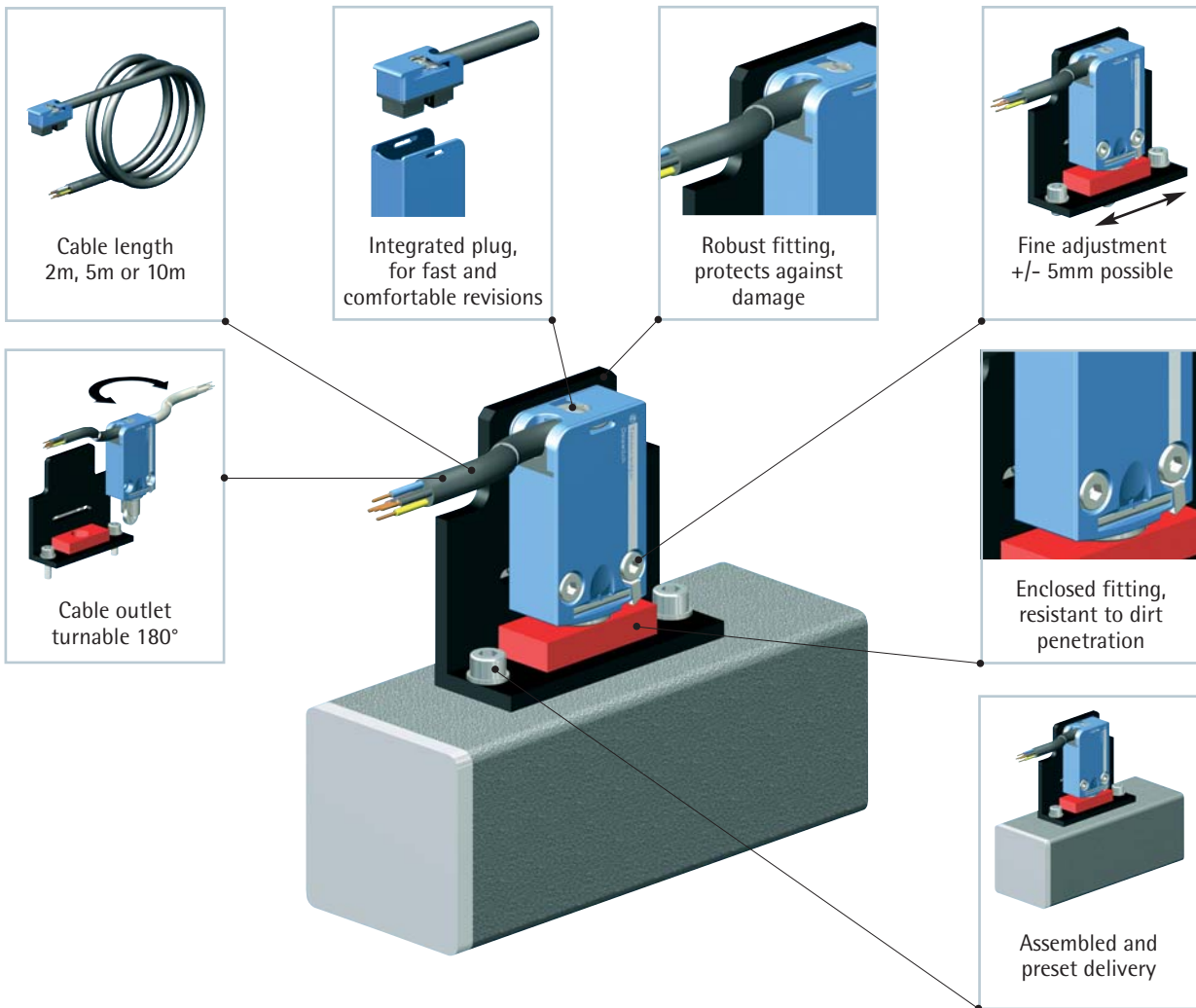

Technical data

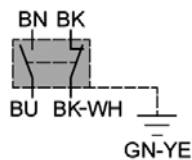
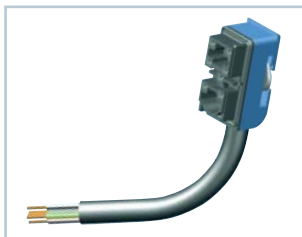

Type:	mechanical limit switch with positively-actuated NC relay
Material:	metal housing and roller plunger
Mode of operation:	1NC + 1NO, snap action contacts
Protection class:	IP67
Temperature range:	-35°C to +85°C
Cable:	PVC black Ø 7.3 mm, 5 x 0.75 mm ²
Electrical duty:	max. 240V AC / 1.5A max. 250V DC / 0.1A
Electrical service life:	5 million DC switching operations at 24V DC/3W 1 million AC switching operations at 230V AC/0.5A

⚡ NC	BK	black
	BK-WH	black-white
⚡ NO	BU	blue
	BN	brown
⚡ Protective earth conductor	GN-YE	green-yellow



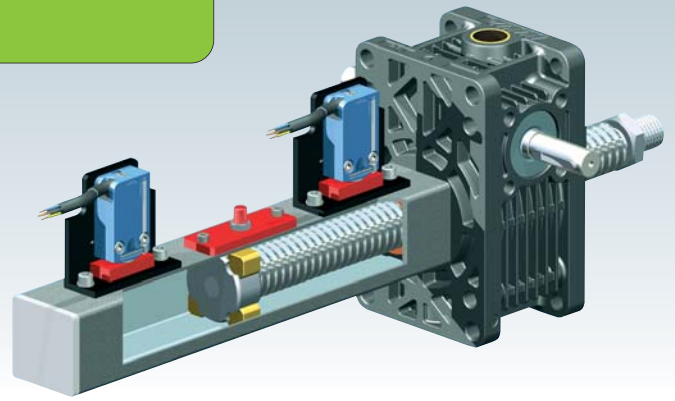

Limit switch set

Dimensions

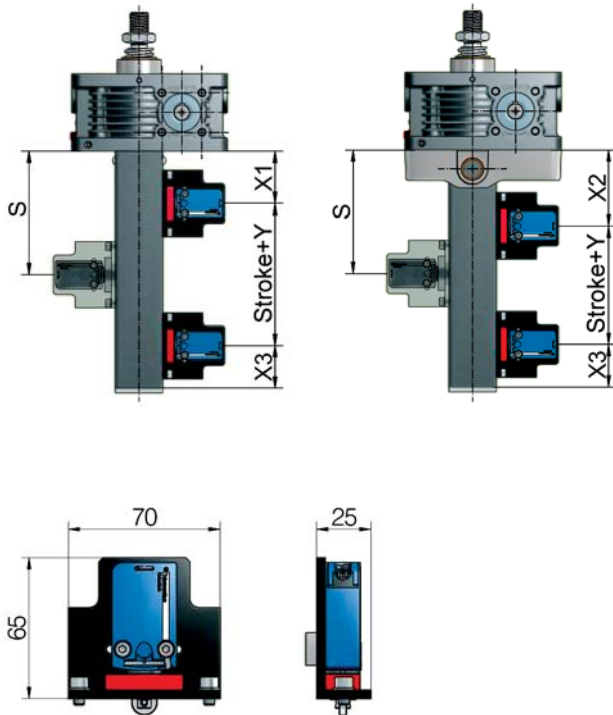

Size	Screw	X1	X2	X3	Y
GSZ-2	Tr 16x4	48	70	48	21
Z-5	Tr 18x4	49	70	45	25
	KGT 16x05, x10	49	70	45	25
Z-10	Tr 20x4	52	72	45	24
	KGT 25x05, x10	52	72	45	24
	KGT 25x25	77	77	68	24
	KGT 25x50	142	142	133	24
Z-25	Tr 30x6	56	80	45	24
	KGT 32x05, x10, x20	56	80	45	24
	KGT 32x40	91	91	78	24
Z-35	Tr 40x7	64	90	45	34
Z-50	Tr 40x7	65	90	45	34
	KGT 40x5, x10, x20	65	90	45	34
	KGT 40x40	90	90	68	34
Z-50/Tr50	Tr 50x8	65	90	45	34
	Tr 55x9	65	110	45	34
Z-100	KGT 50x10	65	110	45	34
	KGT 50x20	70	110	48	34
	KGT 50x40	110	110	88	34
	KGT 50x60	155	155	128	34
Z-150	Tr 60x9	70	120	45	34
	KGT 63x10	70	120	45	34
	KGT 63x20	75	120	48	34
	KGT 63x40	115	120	88	34
	KGT 63x60	155	155	128	34
Z-250	Tr 80x16	75	-	45	30
	KGT 80x10	75	-	45	30
	KGT 80x20	82	-	50	30
	KGT 80x40	122	-	90	30
	KGT 80x60	162	-	130	30
Z-350	Tr 100x16	85	-	50	31
Z-500	Tr 120x16	102	-	55	40
Z-750	Tr 140x20	110	-	55	40
Z-1000	Tr 160x20	110	-	55	40

Limit switch position

Ordering code

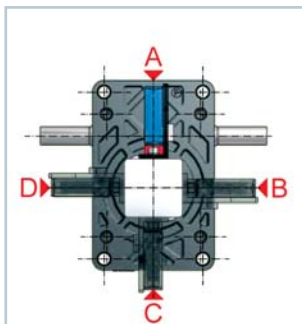

(only A and C permissible for GSZ-2)

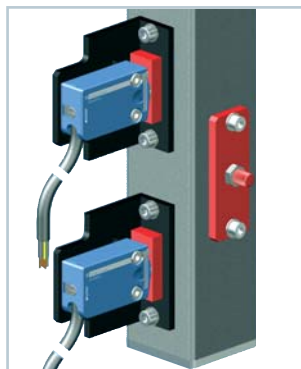

Ordering example:
1 off Z-25-ES-5-G-A
1 off Z-25-ES-5-E-A



Ordering code for limit switch set:

Z-25-ES-5-G-A

Gearbox size
Cable length
2m, 5m (standard) or 10m
Installation
G = gearbox face (standard)
E = end of the protective tube (standard)
S = special position, S = ?? mm
V = set pre-assembled
Limit switch position
A (standard), B, C or D



Datasheet with all technical details on request.

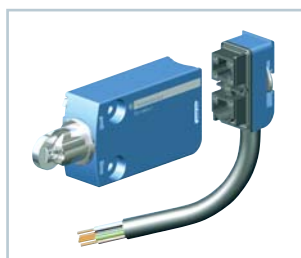

Ordering code for an single switch:

Z-25-ES-5

Cable length
2m, 5m or 10m, 0 = without cable

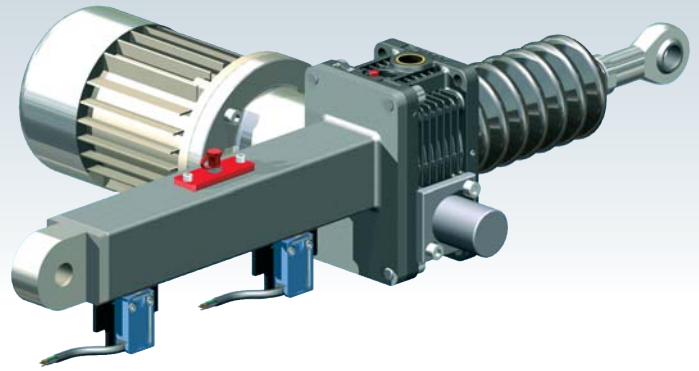

Pivoting support tube STRO

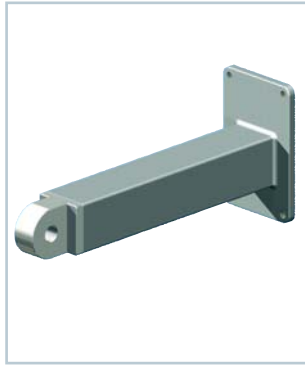

Axis of pivoting

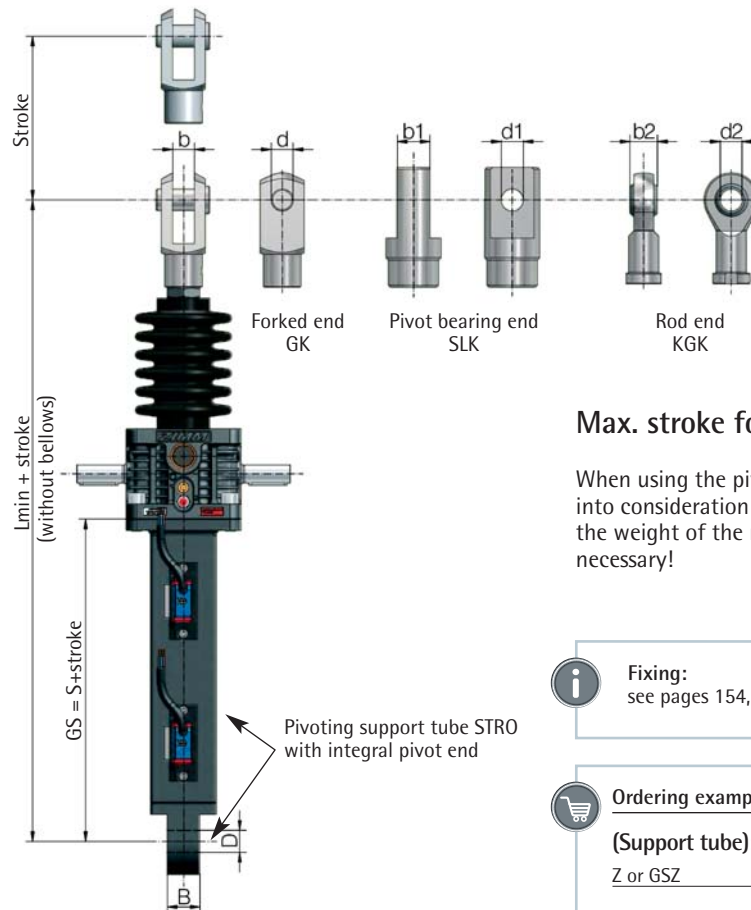
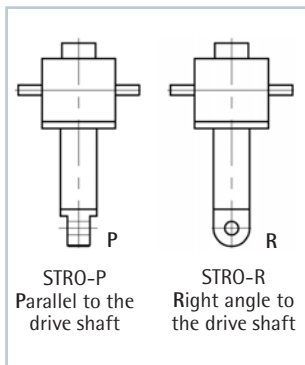

Max. stroke for this type: 500 mm!

When using the pivoting support tube, take into consideration the torques arising due to the weight of the motor etc. - support is necessary!



Fixing:
see pages 154, 159



Ordering example:

(Support tube): Z-25-STRO-P, GS=150mm
Z or GSZ

Size	Options	S	L min. GK	L min. SLK	L min. KGK	d	b	d1	b1	d2	b2	D	B
Z-5	Standard	82	224	224	226	12	12	12	18	12	10	12	20
	with AS/VS	97	239	239	241	12	12	12	18	12	10	12	20
	with ESSET	155	297	297	299	12	12	12	18	12	10	12	20
Z-10	Standard	94	262	262	267	14	14	14	24	15	12	20	30
	with AS/VS	114	282	282	287	14	14	14	24	15	12	20	30
	with ESSET	166	334	334	339	14	14	14	24	15	12	20	30
Z-25	Standard	98	303	303	300	20	20	20	30	20	16	20	30
	with AS/VS	118	323	323	320	20	20	20	30	20	16	20	30
	with ESSET	170	375	375	372	20	20	20	30	20	16	20	30
Z-35	Standard	117	390	362	380	30	30	30	35	30	22	30	35
	with AS/VS	147	420	392	410	30	30	30	35	30	22	30	35
	with ESSET	203	476	448	466	30	30	30	35	30	22	30	35
Z-50	Standard	137	426	398	416	30	30	30	35	30	22	40	50
	with AS/VS	167	456	428	446	30	30	30	35	30	22	40	50
	with ESSET	219	508	480	498	30	30	30	35	30	22	40	50
Z-50/Tr50	Standard	137	454	418	452	35	36	35	40	40	28	40	50
	with AS/VS	167	484	448	482	35	36	35	40	40	28	40	50
	with ESSET	219	536	500	534	35	36	35	40	40	28	40	50
Z-100	Standard	157	539	503	537	35	36	35	40	40	28	40	50
	with AS/VS	187	569	533	567	35	36	35	40	40	28	40	50
	with ESSET	219	601	565	599	35	36	35	40	40	28	40	50

For a bellows extension, see Section 8 - Length Calculation

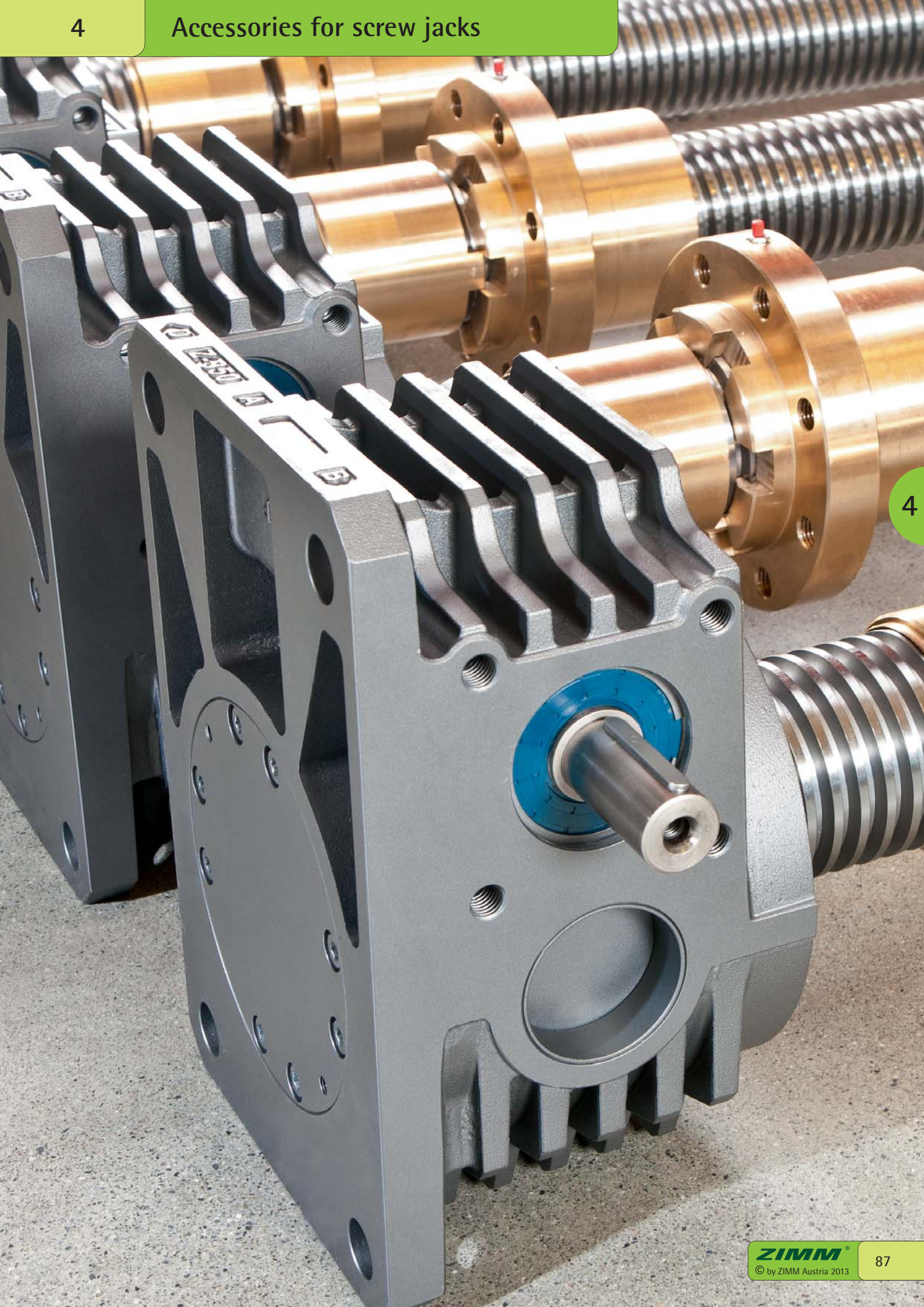

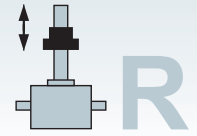

Nuts for rotating version R

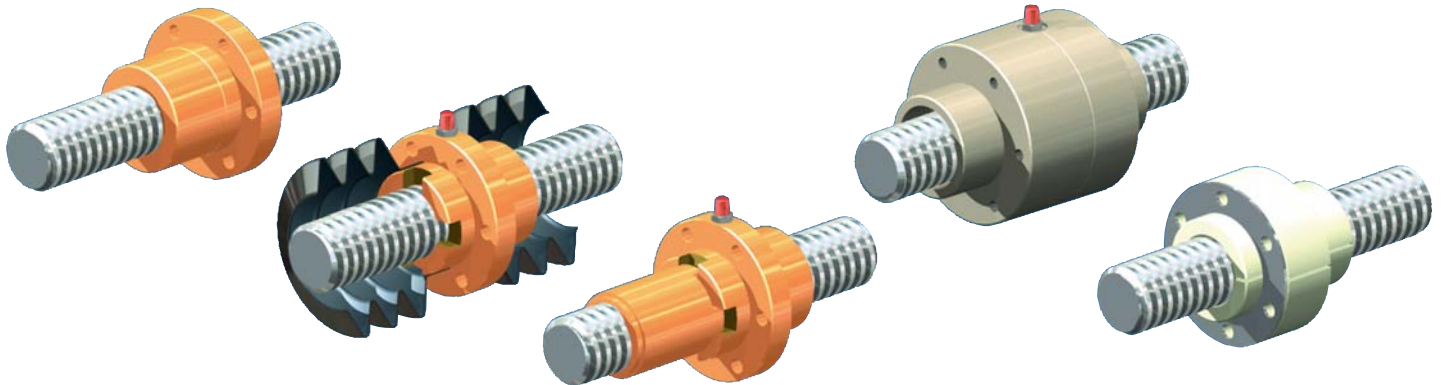

Flange nut FM
Standard nut for simple applications

Duplex nut DM
- Bellows can be attached both sides
- Uniform \varnothing on gearbox neck, nut and opposed bearing plate
- Grease nipple or connection to central lubrication or lubricator (page 120)

Safety nut SIFA
In combination with duplex nut or self-aligning nut.
For function and application see Sections 2+3

Self-aligning nut PM
- Angular compensation up to max. 3°
- Bellows can be attached both sides
- Uniform \varnothing on gearbox neck, nut and opposed bearing plate
- Grease nipple or connection to central lubrication or lubricator (page 120)

Greaseless nut FFDM
- Specially suitable for dry running (such as textiles, foodstuffs, chemicals,...)
- Bellows can be attached both sides
- Reinforced with a stainless steel washer

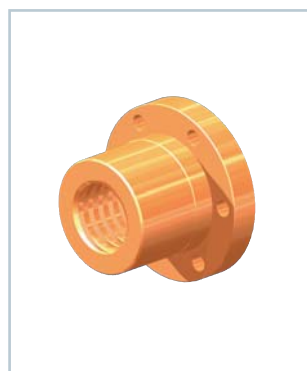

Flange nut Z-..-FM

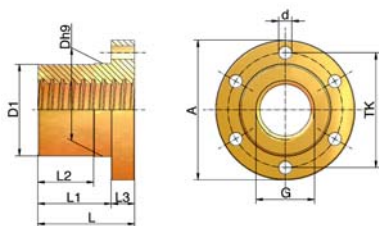

Part no.	G	D1*	Dh9	TK	A	d (6x)	L	L1	L2	L3	kg
GSZ-2-FM	Tr 16x4	28	38	48	6	35	23	15	12	0.25	
Z-5-FM	Tr 18x4	28	38	48	6	35	23	15	12	0.23	
Z-10-FM	Tr 20x4	32	45	55	7	44	32	24	12	0.35	
Z-25-FM	Tr 30x6	38	50	62	7	46	32	24	14	0.41	
Z-35/50-FM	Tr 40x7	63	78	95	9	66	50	38	16	1.71	

Identical to the previous MSZ type
Material: 2.1090.01 (RG7 bronze)

Quality: 7H DIN 103

Right-handed (left-handed, double-pitch on request)

*D1=Dh9-0.2 mm

Option: Plastic nut
GSZ-2-FM-K
Material: High-performance polymer



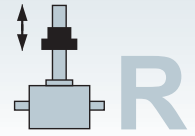

Nuts for rotating version R

Duplex nut Z...-DM

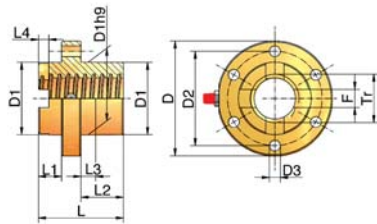

Part no.	Tr	D	D1	D2	D3	L	L1	L2	L3	L4	F	kg
GSZ-2-DM	Tr 16x4	50	26	40	5.5	45	13	20	8	6	6	0.3
Z-5-DM ¹⁾	Tr 18x4	52	29	40	6	45	13	20	8	6	6	0.3
Z-10-DM ¹⁾	Tr 20x4	68	39	54	7	45	13	20	8	6	8	0.57
Z-25-DM ¹⁾	Tr 30x6	79	46	61	7	50	13	23	8	7	12	0.8
Z-35/50-DM ¹⁾	Tr 40x7	95	60	78	9	70	18	36	12	8.5	15	1.54
Z-100-DM	Tr 55x9	130	85	108	11	90	18	54	18	10	20	4.1
Z-150-DM	Tr 60x9	140	90	116	13	115	20	75	20	10	20	5.3
Z-250-DM ¹⁾	Tr 80x16	185	120	153	17	140	25	85	30	14	25	12.2
Z-350-DM ¹⁾	Tr 100x16	230	145	189	23	160	25	100	35	14	24	21.6
Z-500-DM ¹⁾	Tr 120x16	255	170	214	23	180	30	110	40	14	30	30.5
Z-750-DM	Tr 140x20	289	200	252	23	220	30	140	50	18	30	58.3
Z-1000-DM ¹⁾	Tr 160x20	350	250	300	26	320	50	210	70	18	35	155

¹⁾Compatible with the previous MSZ type
Material: 2.1090.01 (RG7 bronze); quality: 7H DIN 103
Right-handed (left-handed, double-pitch on request)
Threaded grease nipple, up to Z-50 G1/8", from Z-100 G1/4"

Safety nut Z...-SIFA-R

see also Sections 2+3

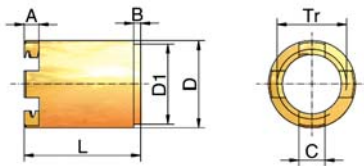
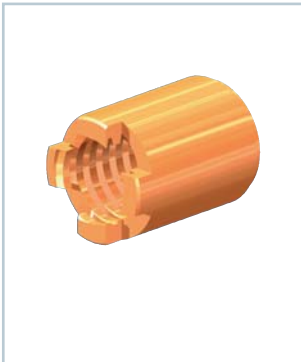

Part no.	Tr	A	B	C	D	D1	L	kg
GSZ-2-SIFA-R	Tr 16x4	6	-	6	22	-	28	0.05
Z-5-SIFA-R ¹⁾	Tr 18x4	6	3	6	24	20	28	0.05
Z-10-SIFA-R ¹⁾	Tr 20x4	6	3	8	28	23	42	0.11
Z-25-SIFA-R ¹⁾	Tr 30x6	7	4	12	38	33	47.5	0.20
Z-35/50-SIFA-R ¹⁾	Tr 40x7	8.5	4	15	50	46	67	0.46
Z-100-SIFA-R	Tr 55x9	10	5	20	65	59	87	1.10
Z-150-SIFA-R	Tr 60x9	10	5	20	70	64	100	1.20
Z-250-SIFA-R ¹⁾	Tr 80x16	14	6	25	100	90	115	3.30
Z-350-SIFA-R ¹⁾	Tr 100x16	14	6	24	120	110	115	4.07
Z-500-SIFA-R ¹⁾	Tr 120x16	14	6	30	135	125	128	6.02
Z-750-SIFA-R ¹⁾	Tr 140x20	18	6	30	170	150	151	13.8
Z-1000-SIFA-R ¹⁾	Tr 160x20	18	6	35	190	170	186	19.8

¹⁾Compatible with the previous MSZ type
Material: RG7

Cardan adapters DMA

for duplex nuts DM
see pages 154, 159

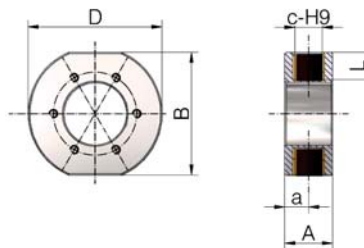
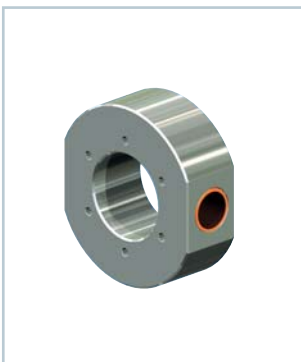

Part no.	B	D	c-H9	L	A	a	kg
Z-5-DMA	72	78	16	15	30	15	1.0
Z-10-DMA	72	78	16	15	30	15	0.9
Z-25-DMA	90	98	20	20	36	18	1.4
Z-35-DMA	100	116	28	15	46	23	2.3
Z-50-DMA	100	116	30	15	46	23	2.3
Z-100-DMA	140	156	40	25	60	30	4.8
Z-150-DMA	145	160	50	25	76	38	6.8
Z-250-DMA	185	206	60	30	90	45	12.7

Material: Steel, corrosion-resistant; pivot bearing: Bronze, PTFE coated

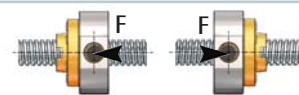

Main direction of loading
Select the main direction of loading so that tensile loads on the nut are avoided

Driving flange TRMFL

for flange nut Z...-FM

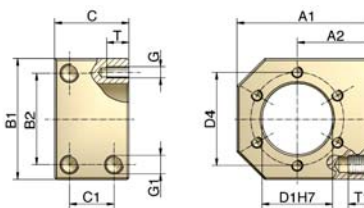
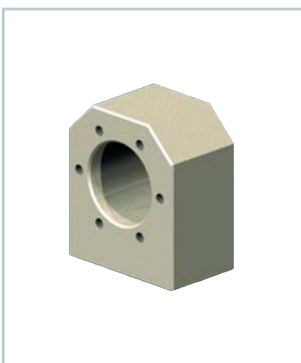

Part no.	for FM	A1	A2max*	A2min*	B1	B2
TRMFL-18x4**	Tr 18x4**	60	35.0	25.0	50	34
TRMFL-20x4	Tr 20x4	68	37.5	29.0	58	39
TRMFL-30x6	Tr 30x6	75	42.5	32.5	65	49
TRMFL-40x7	Tr 40x7	120	70.0	50.0	100	76

Part no.	C	C1	G1	D1	D4	GxT	kg
TRMFL-18x4	40	24	M8x15	28	38	M5x10	0.7
TRMFL-20x4	40	24	M8x15	32	45	M6x12	0.9
TRMFL-30x6	40	24	M10x15	38	50	M6x12	1.1
TRMFL-40x7	65	41	M14x25	63	78	M8x14	4.5

* Supplied ex-works with size A2max.
Can be machined by the customer to A2min.

** Suitable also for GSZ-2-FM (Tr 16x4)

Material: steel, corrosion-resistant

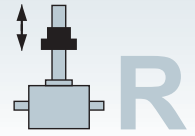

Nuts for rotating version R



Self-aligning nut Z-...-PM

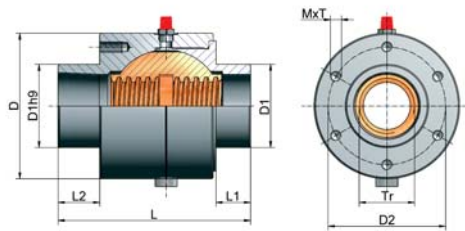

Advantage

- Angular compensation up to $\pm 3^\circ$
- Grease nipple or connection thread to central lubrication
- Bellows can be connected

Application:

(Welded) fabrications often exhibit angular errors, which lead to rapid wear of the trapezoidal screw nuts. The self-aligning nut PM can compensate small angular errors on the attachment face up to maximum $\pm 3^\circ$. A large grease reservoir increases the maintenance intervals and extends the service life.

CAUTION:

Self-aligning nuts cannot compensate parallelism errors between screws or between screws and guides. Take care to ensure precise alignment. The attachment faces for the gearboxes must therefore be exactly at right angles to the guides.

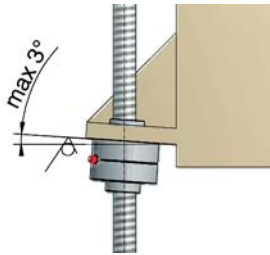

Part no.	Thread Tr d x P	D	D1	D2
Z-5-PM ¹⁾	Tr 18x4	52	29	40
Z-10-PM ¹⁾	Tr 20x4	74	39	60
Z-25-PM ¹⁾	Tr 30x6	88	46	70
Z-35/50-PM ¹⁾	Tr 40x7	105	60	85
Z-100-PM	Tr 55x9	148	85	120
Z-150-PM	Tr 60x9	165	90	125
Z-250-PM	Tr 80x16	225	120	170
Z-350-PM	Tr 100x16	280	145	215

Part no.	M x T	L	L1	L2	LS ²⁾	kg
Z-5-PM ¹⁾	M5x12	78	13	21	123	0.66
Z-10-PM ¹⁾	M6x12	83	13	24	128	1.49
Z-25-PM ¹⁾	M6x12	95	13	27	158	2.36
Z-35/50-PM ¹⁾	M8x16	129	15	30	212	5.04
Z-100-PM	M10x20	190	15	45	298	15.1
Z-150-PM	M12x24	210	15	45	330	21.9
Z-250-PM	M16x32	224	20	40	369	47.0
Z-350-PM	M20x40	275	20	40	455	94

¹⁾Identical to the previous MSZ type

²⁾Overall length PM incl. SIFA safety nut

Trapezoidal screw

DIN 103, quality 7H, right-handed

Screwed grease nipple

Thread $1/8"$ / $1/4"$ from Tr 40x7

Material

Housing: GG 25 (grey cast iron)

Spherical nut: Rg7 (bronze)

Safety nut SIFA

is available for the self-aligning nut on request.

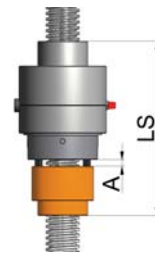

Greaseless nut Z-...-FFDM

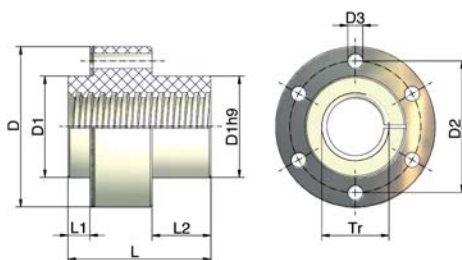
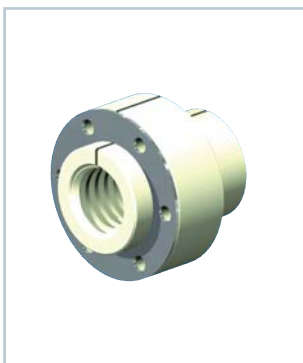

Part no.	Tr	D	D1 ³⁾	D2	D3	L	L1	L2	kN max. Load ²⁾	kg
Z-5-FFDM ¹⁾	Tr 18x4	52	29	40	6	53	11	20	1	0.07
Z-10-FFDM ¹⁾	Tr 20x4	68	39	54	7	53	11	20	2	0.12
Z-25-FFDM ¹⁾	Tr 30x6	79	46	61	7	59	11	23	5	0.18
Z-35/50-FFDM ¹⁾	Tr 40x7	95	60	78	9	85	13	35	7	0.38

Nut material: Plastic, high-performance polymer
Steel ring material: stainless steel

Quality: 7H DIN 103, right-handed

¹⁾Identical to the previous MSZ - FFDM type

²⁾As approximate value, depending on the stroke speed and ambient temperature

³⁾Connection bore for D1 +0.2 mm for thermal expansion

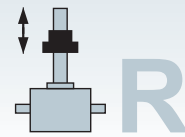

For rotating screw R



Trapezoidal screw Z-.-R-Tr



Material: C35 or Ck45 (stainless steel on request)
 Quality: DIN 103, 7e rolled, from Tr 80 whirled
 Pitch accuracy 0.2 mm / 300 mm
 Right-handed (double-pitch, left-handed on request)

Part no.	Tr	Ø	LA	kg/m
GSZ-2-R-Tr	Tr 16x4	10j6	12	1.2
Z-5-R-Tr	Tr 18x4	12j6	15	1.6
Z-10-R-Tr	Tr 20x4	15j6	20	2.0
Z-25-R-Tr	Tr 30x6	20j6	25	4.5
Z-35-R-Tr	Tr 40x7	25j6	30	8.0
Z-50-R-Tr	Tr 40x7	25j6	30	8.0
Z-100-R-Tr	Tr 55x9	40j6	45	16
Z-150-R-Tr	Tr 60x9	45j6	55	19
Z-250-R-Tr	Tr 80x16	60j6	75	32
Z-350-R-Tr	Tr 100x16	80j6	100	52
Z-500-R-Tr	Tr 120x16	95j6	120	77
Z-750-R-Tr	Tr 140x20	100j6	120	105
Z-1000-R-Tr	Tr 160x20	130j6	175	139



Opposed bearing plate GLP

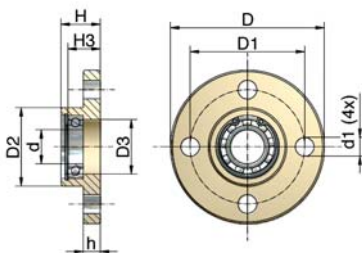

Material: Steel, corrosion-resistant
 Hard anodised aluminium (GSZ-2-GLP)
 Up to Z-150 stainless steel bearings
 The ball bearing is already fitted at delivery
 Identical to the previous MSZ type

Part no.	ØD	ØD1	ØD2	ØD3	Ød	Ød1
GSZ-2-GLP	50	40	26	16	10	5.5
Z-5-GLP	65	48	29	20	12	9
Z-10-GLP	80	60	39	28	15	11
Z-25-GLP	90	67	46	32	20	11
Z-35/50-GLP	110	85	60	42	25	13
Z-100-GLP	150	117	85	60	40	17
Z-150-GLP	170	130	90	68	45	21
Z-250-GLP	210	165	120	85	60	26
Z-350-GLP	265	205	145	95	80	26
Z-500-GLP	310	240	170	130	95	38

Part no.	h	H	H3	Lager	Si ring	kg
GSZ-2-GLP	6	16	12	61900.2RS	J 22	0.05
Z-5-GLP	7	20	13	61901.2RS	J 24	0.17
Z-10-GLP	8	21	17	6002.2RS	J 32	0.30
Z-25-GLP	10	23	19	61904.2RS	J 37	0.48
Z-35/50-GLP	15	30	22	6005.2RS	J 47	1.05
Z-100-GLP	20	50	35	6008.2RS	J 68	3.10
Z-150-GLP	25	50	31	6009.2RS	J 75	3.70
Z-250-GLP	30	60	50	2x6012.2RS	J 95	6.90
Z-350-GLP	32	65	54	2x6016.2RS	J125	11.50
Z-500-GLP	40	120	100	2x6019.2RS	J145	24.00

The opposed bearing plate increases the smoothness of operation and the resistance of the screw to buckling.
 Allow 5 mm at the end of the screw for length compensation.



Fitting the bellows

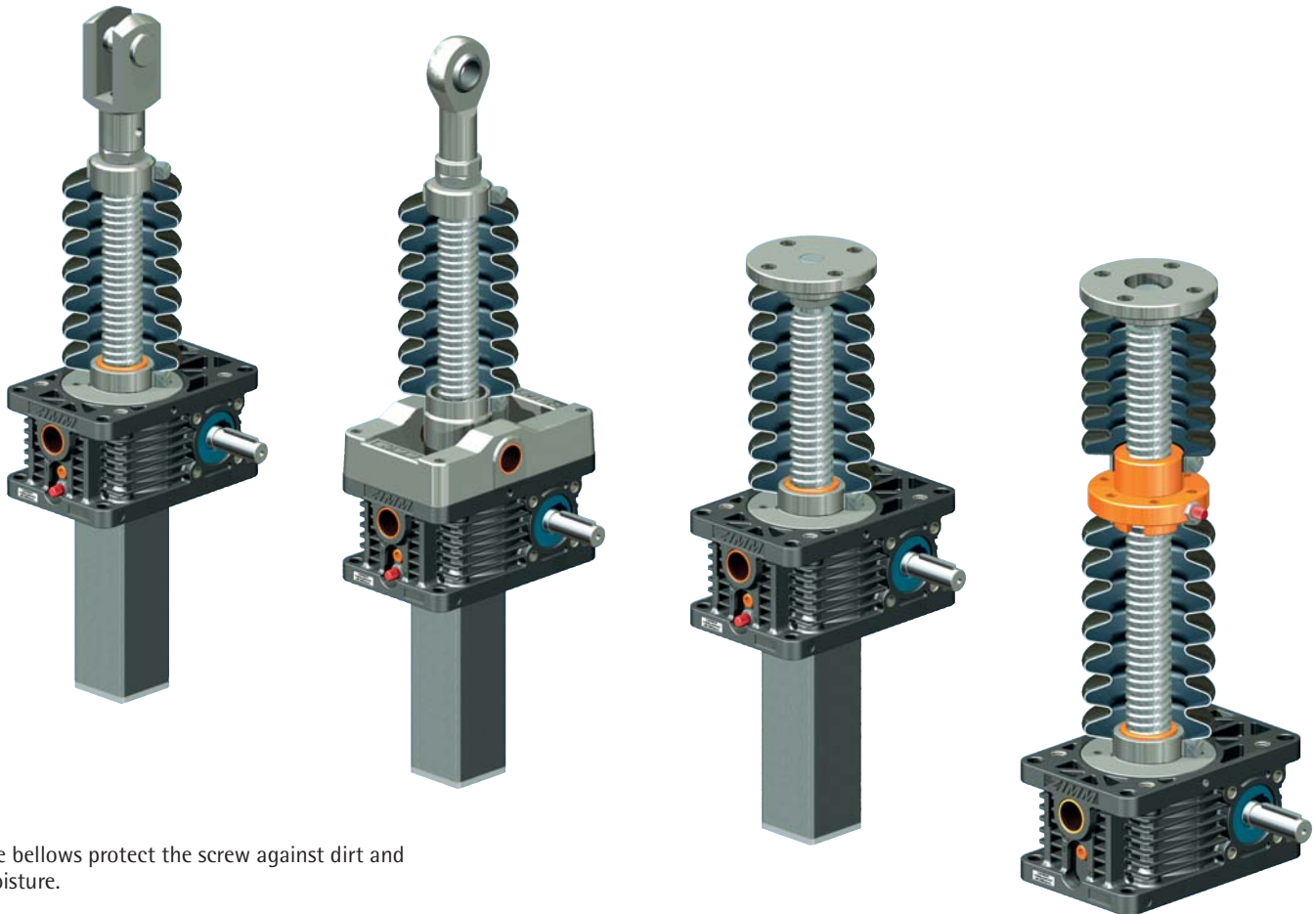

The bellows protect the screw against dirt and moisture.

PLEASE NOTE:

The bellows must not be compressed to less than the ZD dimension nor extended beyond the AZ dimension.

If the stroke is longer than 1000 mm, fit a bellows with an extension block. Take into consideration that when the bellows is fitted

horizontally it must not touch the screw: Risk of serious damage! Use support rings to avoid such damage.

Protect the screws, especially during on-site assembly, against: building site dust, grinding dust from angle grinders,

weld spatter, etc. Protect the bellows against direct sunshine.

Take into consideration also that the thermal insulation effect of the bellows reduces the maximum duty cycle of the screw jack.

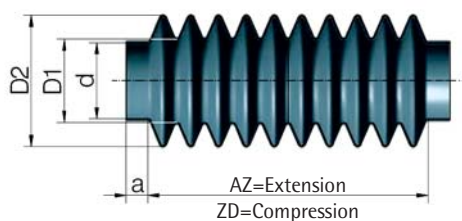
**Bellows Z-...-FB, round**

Part no.	a	d	ZD	AZ	Stroke	D1	D2	kg
GSZ-2-FB 182	11	26	38	220	182	26	55	0.08
GSZ-2-FB 364	11	26	98	462	364	26	55	0.16
Z-5-FB-265	10	29	35	300	265	40	76	0.15
Z-10-FB-340	10	39	80	420	340	40	80	0.21
Z-25-FB-300	15	46	70	370	300	50	83	0.25
Z-35/50-FB-390	15	60	85	475	390	66	102	0.43
Z-100-FB-285	15	85	75	360	285	85	118	0.29
Z-150-FB-350	15	90	50	400	350	92	141	0.44
Z-250-FB-390	15	120	90	480	390	125	166	1.10
Z-350-FB-600	15	145	100	700	600	172	236	2.40

Material: PVC, NBR (GSZ-2), operating temperature +70°C up to max. +85°C, cold fracture temperature -32°C, incl. 2 galvanised hose clips.

CAUTION: For screw extensions, see Sections 2+3 identical to the previous MSZ type

Bellows FB

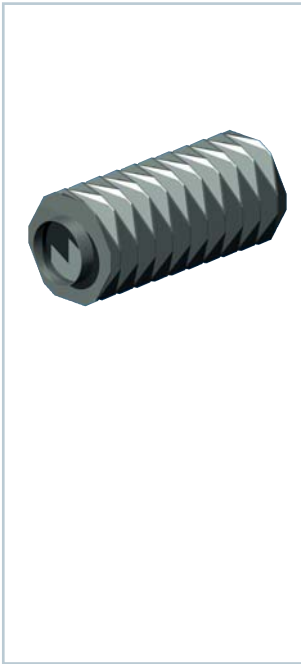

Bellows Z-..-FB, polygonal

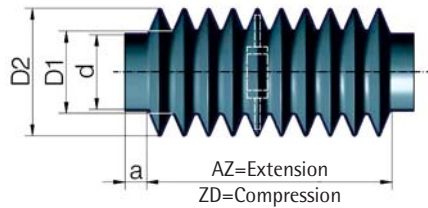

Material: Polyurethane-coated polyester fabric type OZ-23, temperature stability -15°C to +70°C, incl. 2 galvanised hose clips.

For screw extensions, see Sections 2+3

CAUTION:
For special bellows, dimensions ZD, AZ and DZ may be different!

Part no.	a	d	ZD	AZ	Stroke	D1	D2	kg
Z-5-FB-500	10	29	100	600	500	38	68	0.19
Z-5-FB-800	10	29	120	920	800	38	68	0.30
Z-10-FB-700	10	39	100	800	700	38	75	0.23
Z-10-FB-1000	10	39	150	1150	1000	38	75	0.32
Z-25-FB-700	15	46	100	800	700	63	105	0.32
Z-25-FB-1000	15	46	120	1120	1000	63	105	0.43
Z-35/50-FB-600	15	60	72	672	600	63	105	0.23
Z-35/50-FB-1000	15	60	130	1130	1000	63	105	0.42
Z-35/50-FB-1200	15	60	125	1325	1200	63	105	0.42
Z-35/50-FB-1500	15	60	180	1680	1500	63	105	0.51
Z-100-FB-600	15	85	72	672	600	63	105	0.29
Z-100-FB-1000	15	85	130	1130	1000	63	105	0.40
Z-100-FB-1500	15	85	180	1680	1500	63	105	0.44
Z-150-FB-600	15	90	72	672	600	110	150	0.40
Z-150-FB-1000	15	90	130	1130	1000	110	150	0.60
Z-150-FB-1500	15	90	180	1680	1500	110	150	0.82
Z-250-FB-600	15	120	72	672	600	110	150	0.40
Z-250-FB-1000	15	120	130	1130	1000	110	150	0.60
Z-250-FB-1500	15	120	180	1680	1500	110	150	0.82
Z-350-FB-900	15	145	108	1008	900	150	200	0.70
Z-350-FB-1500	15	145	180	1680	1500	150	200	1.10

IMPORTANT! When ordering, please specify:
When mounted horizontally, the bellows must be fitted with suitable support rings, so as to avoid wear due to rubbing against the trapezoidal thread of the screw.
For lengths longer than 1000 mm, an extension block is necessary.
Compatible with the previous MSZ types

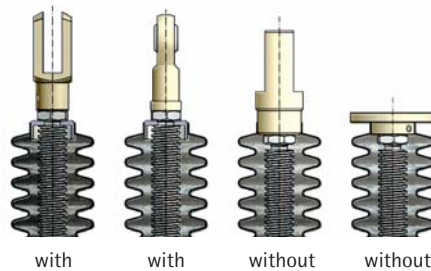
Bellows fixing ring
Z-..-FBR

The fixing ring FBR is used to secure the bellows FB to the forked end GK or rod end KGK. Identical to the previous MSZ types

If a forked end GK or rod end KGK is included in the scope of the order, the fixing ring is supplied automatically.
Otherwise, please order it separately.

Ordering example:
Z-25-FBR

Material: POM (plastic)

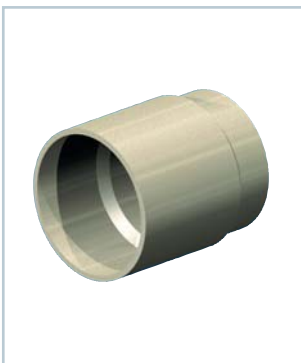

Bellows adapter Z-..-FBA

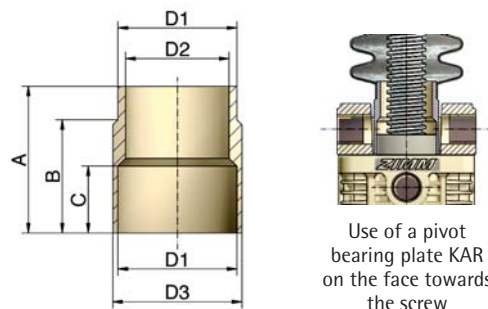

Part no.	D1	D2	D3	A	B	C
Z-5-FBA	29	25	32	44	32	20
Z-10-FBA	39	30	42	42	32	22
Z-25-FBA	46	40	50	57	42	26
Z-35/50-FBA	60	52	65	70	52	40
Z-100-FBA	85	80	90	90	72	50
Z-150-FBA	90	85	95	100	82	50
Z-250-FBA	120	115	125	118	100	60
Z-350-FBA	145	140	150	130	112	60
Z-500-FBA	170	150	180	172	152	70

Material: Aluminium, corrosion-resistant

Spiral spring attachment



Spiral spring cover attachment for types SN/SL

Spiral spring cover attachment for types RN/RL

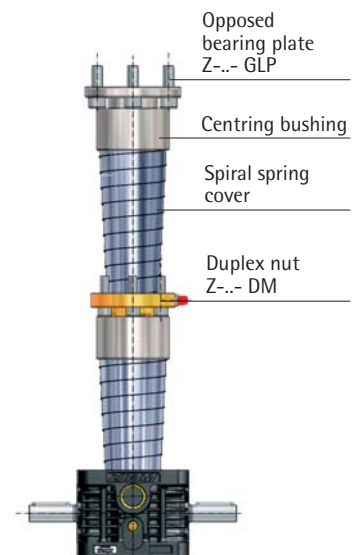
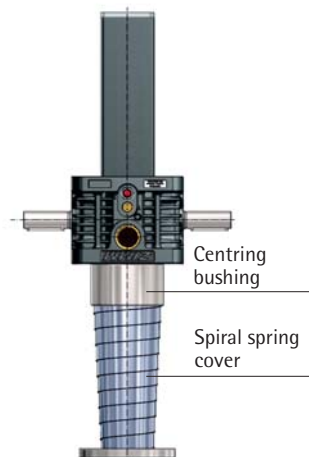
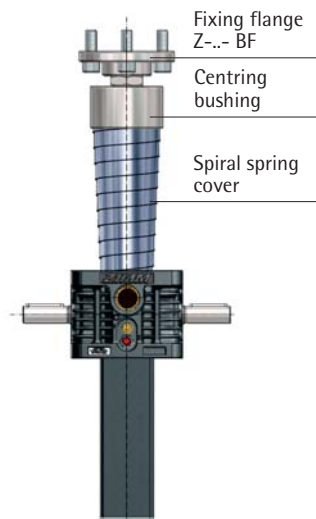
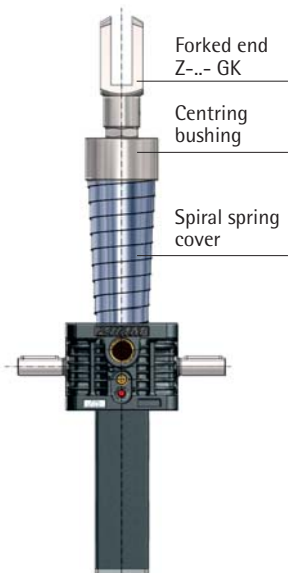

Fitting instructions:

Spiral springs can be used on chip-generating and non-chip generating machines.

The illustrations show how to fit different types of spiral spring covers to various screw jacks.

Centring bushings are required when assembling combinations of different parts; we can include these in our quotation on request.

IMPORTANT:

Spiral springs must under no circumstances be allowed to uncoil. For technical reasons, please specify in your enquiry whether the spiral spring is to be installed horizontally or vertically.

If installation is to be vertical, we recommend that the larger diameter is at the top,

as shown; if it is to be horizontal, the taper should be away from the direction of flow of the chips or other particulate.

A slight film of oil on the spiral spring improves its operation and extends its service life.

Spiral spring cover SF

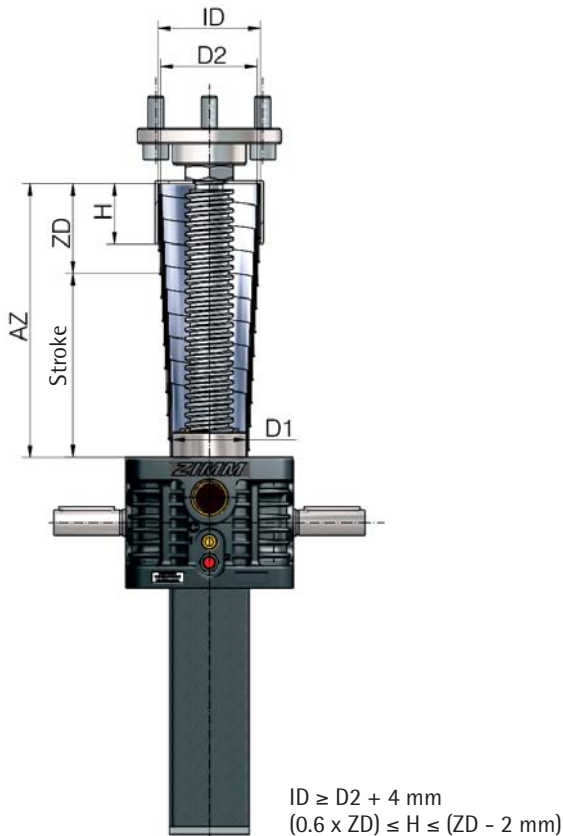
**Material:**

SF: Spring band steel, blued (on request we can also supply versions in stainless steel)

Centring bushing: Plastic (other materials on request)

CAUTION:

The spring travel quoted is the maximum possible. For practical operation, please allow a margin of safety to prevent damage! We recommend preparation of a drawing to determine the fitting position and dimensions of spiral springs.

**Ordering example:**

SF-030-0450-030-H SFZ-ID57-H20

Spiral spring
Least diameter D1
Greatest length AZ*
Least length ZD
H=horizontal installation
V=vertical installation

Centring bushing
Inner diameter
Height

Screw jack Z-5						Bushing			
Type SF	D1	D2	ZD	Stroke	kg	ID	AD	H	
030-0450-030-V	30	53	30	420	0.30	57	61	20	
030-0450-030-H	30	53	30	360	0.30	57	61	20	

Screw jack Z-10						Bushing			
Type SF	D1	D2	ZD	Stroke	kg	ID	OD	H	
040-0450-040-V	40	64	40	410	0.53	69	73	30	
040-0450-040-H	40	64	40	350	0.53	69	73	30	
040-0900-060-V	40	70	60	840	1.09	74	78	36	
040-0900-060-H	40	70	60	720	1.09	74	78	36	
040-1300-075-V	40	84	75	1225	2.20	88	92	50	
040-1300-075-H	40	84	75	1075	2.20	88	92	50	

Screw jack Z-25						Bushing			
Type SF	D1	D2	ZD	Stroke	kg	ID	OD	H	
050-0450-050-V	50	70	50	400	0.64	74	78	36	
050-0450-050-H	50	70	50	300	0.64	74	78	36	
050-0750-060-V	50	80	60	690	1.07	84	88	40	
050-0750-060-H	50	80	60	570	1.07	84	88	40	
050-1200-075-V	50	94	75	1125	2.45	98	104	50	
050-1200-075-H	50	94	75	975	2.45	98	104	50	
050-1500-100-V	50	88	100	1400	2.70	92	96	60	
050-1500-100-H	50	88	100	1200	2.70	92	96	60	

Screw jacks Z-35, Z-50						Bushing			
Type SF	D1	D2	ZD	Stroke	kg	ID	OD	H	
065-0450-050-V	65	88	50	400	0.64	92	96	35	
065-0450-050-H	65	88	50	300	0.64	92	96	35	
065-1100-075-V	65	107	75	1025	2.50	112	118	60	
065-1100-075-H	65	107	75	825	2.50	112	118	60	
065-1500-100-V	65	108	100	1400	3.80	112	118	60	
065-1500-100-H	65	108	100	1200	3.80	112	118	60	
065-2100-120-V	65	113	120	1980	5.65	118	124	80	
065-2100-120-H	65	113	120	1740	5.65	118	124	80	

Screw jack Z-50/Tr50, Z-100						Bushing			
Type SF	D1	D2	ZD	Stroke	kg	ID	AD	H	
090-0650-075-V	90	124	75	575	2.80	128	134	50	
090-0650-075-H	90	124	75	425	2.80	128	134	50	
090-1300-100-V	90	132	100	1200	4.90	136	142	60	
090-1300-100-H	90	132	100	1000	4.90	136	142	60	

Screw jack Z-150						Bushing			
Type SF	D1	D2	ZD	Stroke	kg	ID	AD	H	
100-0800-075-V	100	138	75	725	3.70	143	149	51	
100-0800-075-H	100	138	75	575	3.70	143	149	51	
100-1500-100-V	100	146	100	1400	6.00	150	156	75	
100-1500-100-H	100	146	100	1200	6.00	150	156	75	



Other sizes of spiral springs are available on request.

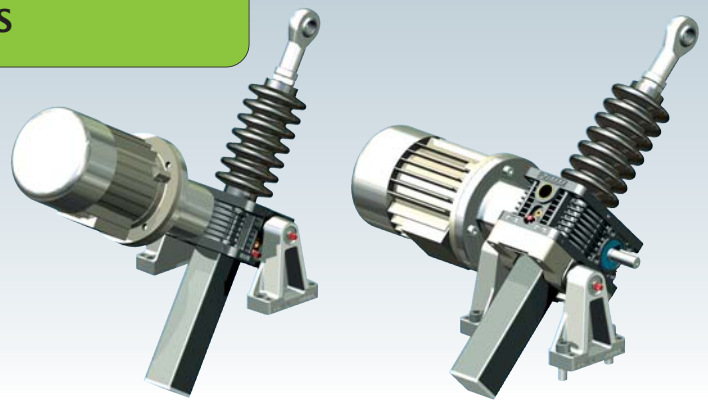

Pivoting – Z-5 to Z-25

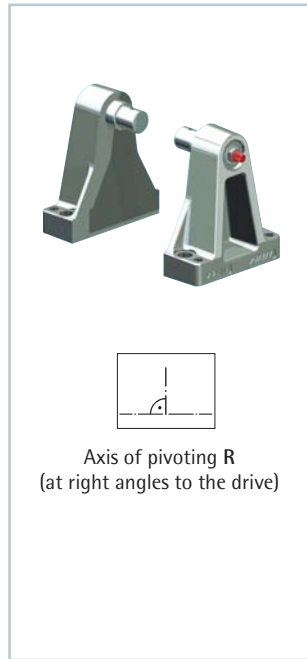

Pivot mounts LB

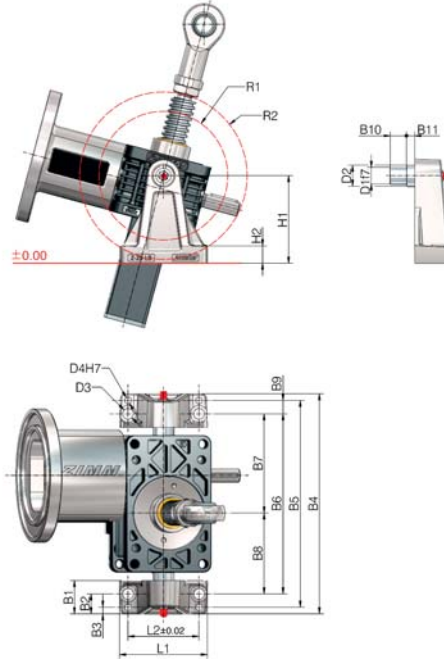

Dimensions	B1	B2	B3	B4	B5	B6	B7	B8	B9	B10	B11
Z-5 (Z-5/10-LB)	40	25	10	200	180	150	84	66	15	15	6
Z-10 (Z-5/10-LB)	40	25	10	220	200	170	95	75	15	15	6
Z-25 (Z-25-LB)	40	24	08	264	248	216	119	97	16	20	10

Dimensions	D1	D2	D3	D4	H1	H2	L1	L2	R1	R2	kg (set)
Z-5 (Z-5/10-LB)	16	22	11	8	80	18	90	70	57	63	0.72
Z-10 (Z-5/10-LB)	16	22	11	8	80	18	90	70	68	74	0.72
Z-25 (Z-25-LB)	20	25	13	8	105	21	105	85	78	100	1.30

Integrated pivot bearing

Simple and economical design:
Pivot bushes are incorporated in the gearbox housing.

Lubrication

The bronze bushes are PTFE-coated and therefore require no lubrication in normal service. We recommend regular lubrication for high loadings.

Design tip

For large motors, long strokes and high load cycles, the variant with the pivot bearing plate KAR is preferable, because the weight of the motor is then taken by the pivoting points and does not affect the screw.

F Refer to the permissible loads listed in Section 8

Material: Aluminium, corrosion-resistant
Bolt: Stainless steel

Part no.:
Z-5/10-LB set (2 items)
Z-25-LB set (2 items)

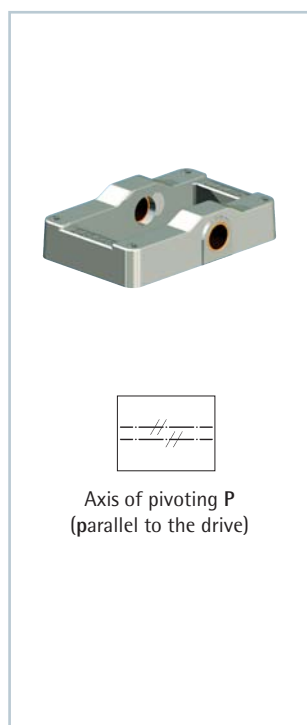

Pivot bearing plate KAR

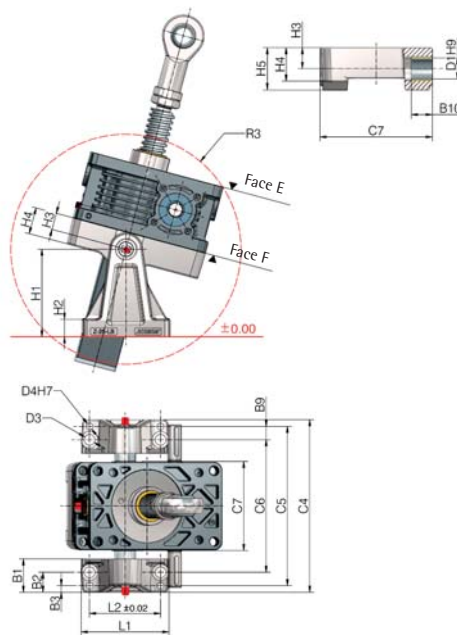

Dimensions	B1	B2	B3	B9	B10	C4	C5	C6	C7	D1	D3
Z-5-KAR	40	25	10	15	15	166	146	116	74	16	11
Z-10-KAR	40	25	10	15	15	179	159	129	87	16	11
Z-25-KAR	40	24	08	16	20	207	191	159	107	20	13

Dimensions	D4	H1	H2	H3	H4	H5	L1	L2	R3	kg
Z-5-KAR	8	80	18	15	21	30	90	70	100	0.24
Z-10-KAR	8	80	18	15	24	30	90	70	116	0.33
Z-25-KAR	8	105	21	20	32	40	105	85	138	0.80

Multi-jack systems

The KAR pivot bearing plate allows several jacks to be arranged in a row.

Lubrication

The bronze bushes are PTFE-coated and therefore require no lubrication in normal service. We recommend regular lubrication for high loadings.

Part no.:
Z-5-KAR
Z-10-KAR
Z-25-KAR

Please specify: mounted on face E or face F

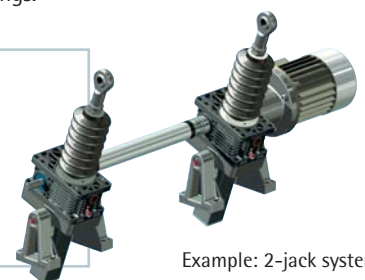

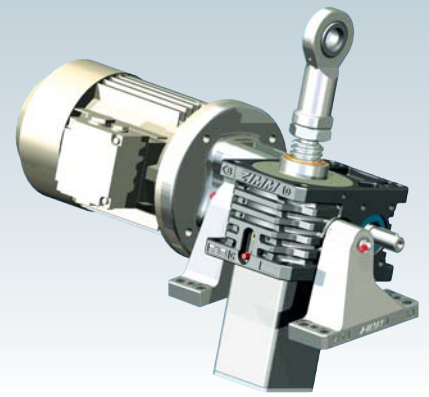

Pivoting – Z-35 to Z-1000

Pivot mounts LB

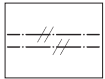
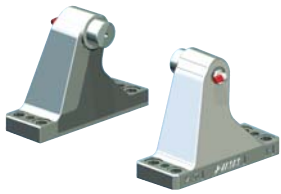

Axis of pivoting P
(parallel to the drive)

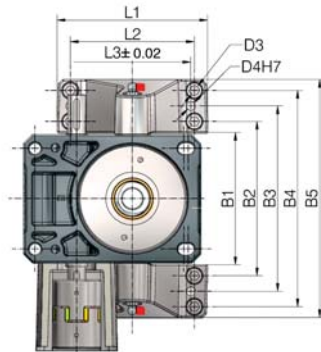
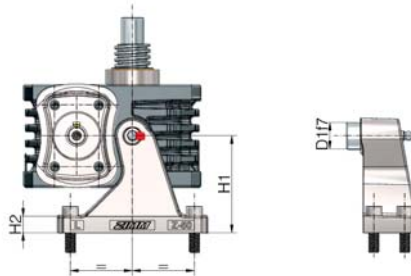

Material: Cast steel, quenched and tempered, corrosion-resistant

From Z-500 the gearbox is mounted the opposite way round, since the footplate is broader than the rest of the housing:



Dimensions	D1	D3	D4	H1	H2	L1	L2
Z-35-LB	28	11	8	85	18	130	106
Z-50-LB	30	13	10	110	18	170	140
Z-100-LB	40	22	20	120	22	260	180
Z-150-LB	50	22	20	135	24	280	200
Z-250-LB	60	26	20	170	32	285	230
Z-350-LB	80	33	25	210	36	380	310

Dimensions	L3	B1	B2	B3	B4	B5	kg (set)
Z-35-LB	106	124	146	174	202	224	3.2
Z-50-LB	140	150	175	210	245	270	5.0
Z-100-LB	225	210	250	290	330	370	11.8
Z-150-LB	235	222	262	312	362	402	18.0
Z-250-LB	220	265	325	400	475	535	31
Z-350-LB	300	302	372	462	552	622	66

Integrated pivot bearing

Simple and economical design:

Pivot bushes are incorporated in the gearbox housing.

Lubrication

The bronze bushes are PTFE-coated and therefore require no lubrication in normal service. We recommend regular lubrication for high loadings.

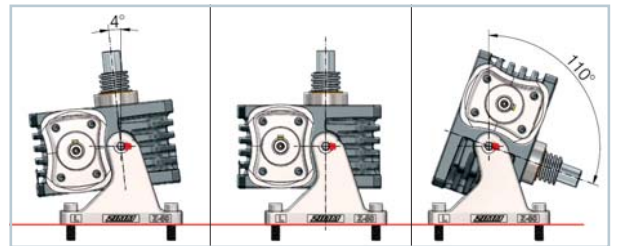

Part no.:

Z-50-LB set
(1x right-handed, 1x left-handed)



Refer to the permissible loads listed in Section 8

Pivot bearing plate Z-35-KAR

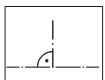
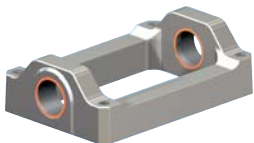

Axis of pivoting R
(at right angles to the drive)

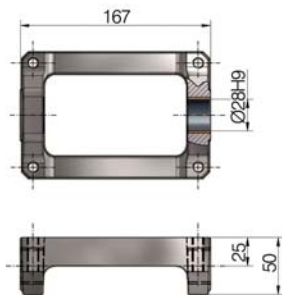

Material: GGG-50

Pivot bearing plate from Z-35

The use of the pivot mounts LB directly within the gearbox housing is the best and most economical solution. Design considerations may in some cases necessitate the use of a pivot bearing plate.

Other sizes of pivot arrangements "R" and "P" are available on request.



Part no.:

Z-35-KAR

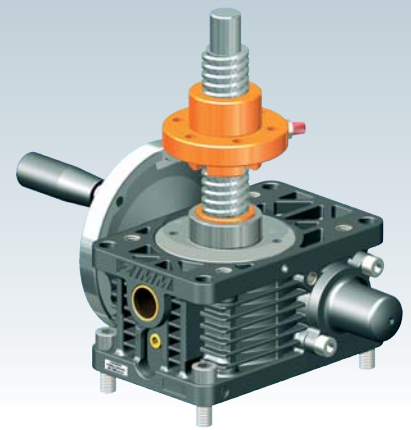

For the S and R version



Handwheel HR

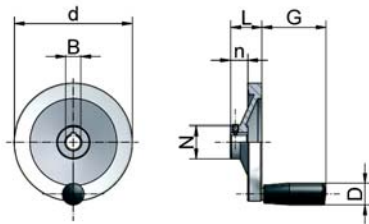

Part no.	d	N	b	n	L	G	D	B H7	B H7	kg
HR-80	80	26	13.0	16	26	42.5	18	8	9/11	0.16
HR-125	125	31	15.0	18	33	67.5	23	6	11/14	0.30
HR-160	160	36	18.0	20	39	82.5	26	14	14/16/19	0.50
HR-200	200	42	20.5	24	45	82.5	26	16	16/19/20	1.00
HR-250	250	48	23.0	28	51	92.5	28	20	20/25	1.30

Material: Aluminium, plastic (handle)

Design: No more than max. 50 - 60 N force should be required at the handle



Ordering example:

Diameter
Bore
N = with keyway and set screw
V = only pilot hole

HR-125-11-N



Protective cap GSZ-2-SK

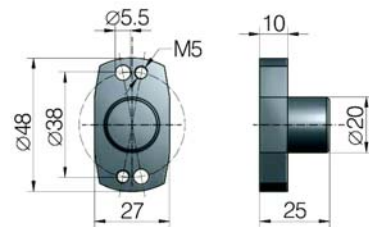

GSZ-2

incl. screws
Material: Hard anodised aluminium

Part no.	D	d	E	F	Screws DIN 912	kg
GSZ-2-SK	20	5.5/M5	25	10	M5x55	0.05

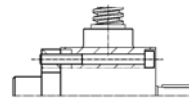

M5x55
Screws are included with the
protective cap

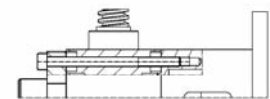

M5x70
Screws are included with the motor
flange / bevel gearbox



Protective cap Z-..- SK

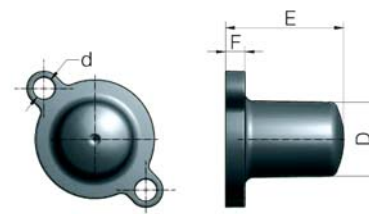

Z-5 to Z-150

Z-250 to Z-1000

incl. screws
Material: Z-5 to Z-150: PA6 GF15,
up to 120°C, briefly 180°C
Material: Z-250 to Z-1000: POM,
up to 100°C, briefly 140°C

Suitable for screw jacks Z, GSZ, MSZ
(MSZ up to size 50) and
bevel gearboxes KSZ, KGZ

Part no.	D	d	E	F	Screws DIN 912	kg
Z-5-SK	25	7	32	8	M6x16	0.02
Z-10-SK	30	9	32	8	M8x16	0.04
Z-25-SK	31	9	49	8	M8x16	0.05
Z-35-SK	35	11	54	8	M10x20	0.07
Z-50-SK	35	11	55	8	M10x20	0.08
Z-100/150-SK	46	13.5	74	8	M12x25	0.12
Z-250-SK	60	17.5	82	25	M16x30	0.70
Z-350-SK	75	20	85	30	M18x30	0.90
Z-500-SK	90	22	125	35	M20x40	1.20
Z-750-SK	110	22	122	28	M20x40	1.50
Z-1000-SK	100	26	142	30	M24x40	2.20

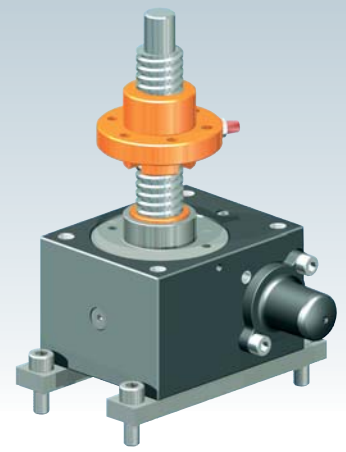

For the S and R version



Fixing strips BFL

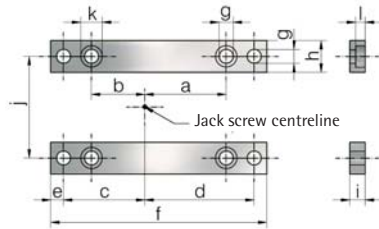

Part no.	a	b	c	d	e	f	g	h	i	j	k	l	kg
GSZ-2-BFL	32	16	29.5	45.5	7.5	90	6.6	14	10	38	11	6.4	0.16
GSZ-5-BFL	39	21	41	59	10	120	9	20	10	52	14	6	0.32
GSZ-10-BFL	49	29	50	70	10	140	9	20	14	63	14	6	0.50
GSZ-25-BFL	64	42	64	86	10	170	11	25	12	81	17	7.5	0.75
GSZ-50-BFL	87	63	90	114	13	230	13	30	20	115	19	7	2.00
GSZ-100-BFL	100	66	101	135	17	270	18	40	25	131	26	11	3.70

Identical to the previous MSZ types

Material: Steel, corrosion-resistant / GSZ-2-BFL: Stainless steel
Incl. screws



Pivot bearing plate KAR

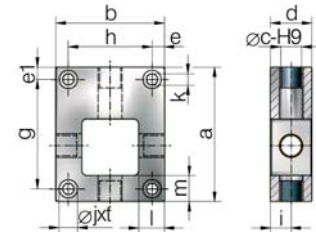

Part no.	a	b	c	d	e	e1	g	h	i	j	k	l	m	t	kg
GSZ-2-KAR ¹⁾	70	50	16	30	6	6	48	38	13	13	6.6	11	13	8	0.16
GSZ-5-KAR	80	72 ²⁾	16	30	10	10	60	52	15	15	9	18	10	9	0.80
GSZ-10-KAR	100	85 ²⁾	16	30	11	11	78	63	15	15	9	16	11	9	1.15
GSZ-25-KAR	130	105 ²⁾	20	40	12	12	106	81	20	18	11	25	25	11	2.80
GSZ-50-KAR	180	145	30	50	15	15	150	115	25	20	13	24	30	13	5.30
GSZ-100-KAR	200	175	40	70	22	17	166	131	35	26	17	40	30	18	11.1

Identical to the previous MSZ types

Material: Steel, corrosion-resistant / GSZ-2-KAR: Aluminium, corrosion-resistant
Incl. screws

¹⁾Pivot mounts GSZ-2-LB available (Z-5/10-LB with shorter journals)

²⁾CAUTION: 2 mm narrower than Z-...-KAR

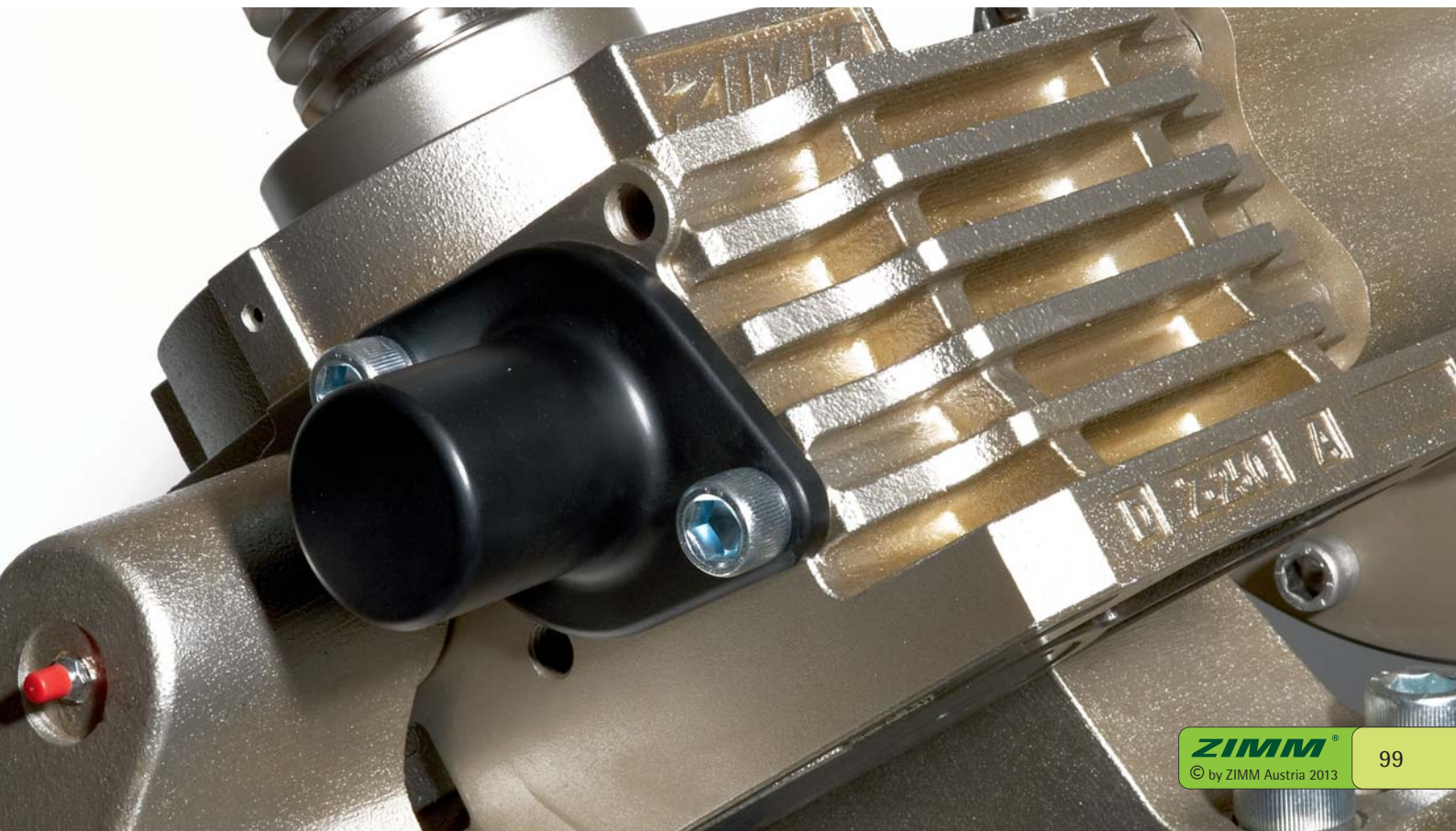

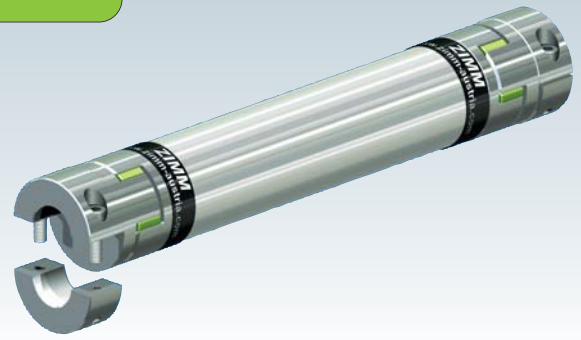

Connecting shaft VWZ

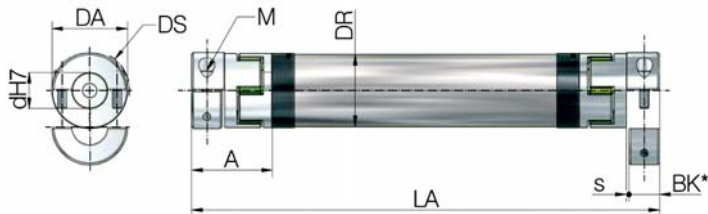

Standard bores "d" [mm]

VWZ-30	8, 9, 10, 11, 12, 14, 15, 16
VWZ-40	9, 10, 11, 12, 14, 15, 16, 18, 19, 20, 22
VWZ-60	10, 11, 12, 14, 15, 16, 18, 19, 20, 22, 24, 25, 28, 30, 32
VWZ-60V	12, 15, 16, 18, 20, 22, 24, 25, 28, 30, 32, 35
VWZ-80	16, 19, 20, 22, 24, 25, 28, 30, 32, 35, 38, 40, 42, 45
VWZ-100	25, 28, 32, 38, 40, 42, 45, 48, 50, 55

Dimensions, technical data

Size	Dimensions								Clamping screw		Moment of inertia		Torsional stiffness		Weight	
	DA [mm]	DS [mm]	DR [mm]	BK* [mm]	s [mm]	A [mm]	LA min [mm]	M 10.9	Tightening torque [Nm]	per coupling [10^{-3}kgm^2]	tube/m [10^{-3}kgm^2]	per star C_{dyn} [Nm/rad]	per tube/m C_{dyn} [Nm/rad]	both couplings [kg]	tube/m [kg]	
VWZ-30	32	32	30	15	1.5	34	99	M4	4	0.01	0.11	1375	1104	0.14	0.58	
VWZ-40	42	44.5	40	17	1.5	46	133	M5	8	0.08	0.2	3700	2332	0.36	0.76	
VWZ-60	56	57	60	30	2	63	177	M6	15	0.24	0.8	9917	8292	0.94	0.97	
VWZ-60V	67	68	60	35	2	73	205	M8	35	0.46	0.8	24417	8292	1.42	0.97	
VWZ-80	82	85	80	40	2	84	249	M10	70	2.4	3	33667	29102	2.98	2.00	
VWZ-100	102	105	100	50	2	97	283	M12	120	6	5.8	67667	58178	4.62	2.47	

*BK = shaft extension clamping length

Torques

Size	Elastomer star		Maximum transmittable torque by clamp hub depending on the bore diameter (clamp force)															Coupling type				
	Rated torque [Nm]	Max. torque [Nm]	Ø9 [Nm]	Ø11 [Nm]	Ø14 [Nm]	Ø16 [Nm]	Ø19 [Nm]	Ø20 [Nm]	Ø22 [Nm]	Ø24 [Nm]	Ø25 [Nm]	Ø28 [Nm]	Ø30 [Nm]	Ø32 [Nm]	Ø38 [Nm]	Ø40 [Nm]	Ø42 [Nm]		Ø45 [Nm]	Ø48 [Nm]	Ø55 [Nm]	
VWZ-30	12	25	21	26	33	37															KUZ-KK-16	
VWZ-40	17	34		41	52	60	70	74	81													KUZ-KK-24
VWZ-60	60	120		60	76	87	104	109	120	131	136	153	164	175								KUZ-KK-32
VWZ-60V	160	320				120		188	206		235			301								KUZ-KK-35
VWZ-80	325	650				325	386	406	447	488	508	568	610	650	772		854	915				KUZ-KK-45
VWZ-100	530	1060									570	638		730	866	914	960	1029	1097	1250		KUZ-KK-60

The max. torque is limited either by the star or by the clamping force

Shafts with split shells

- Split shells permit easy radial insertion
- High concentricity
- High clamping forces
- Low moment of inertia

- Stepless adjustment facility thanks to the clamp hub rather than a fitted drive key
- Drive keyway available on request
- Material: High-tensile aluminium (stainless steel on request)

Elastomer star

- Permanently free of play, dampens vibration
- Shore hardness 64D
- Colour: ZIMM green
- Temperature range: 0°C to +70°C reduced to -20°C, to +100°C (Mx0.55)



Ordering example:

VWZ-60-LA 1800-20/25

Size
Length
Bores for couplings

n=1500 rpm (specify the speed)

VWZ length calculation (identical for Z and GSZ)

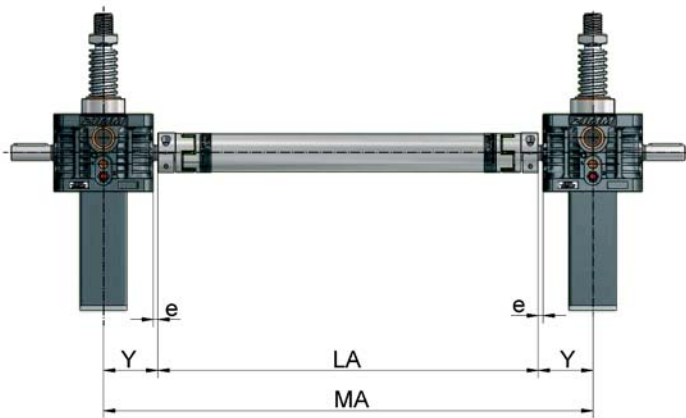

LA = External length (incl. coupling)
MA = Distance between centres of gearboxes



Screw jack	Connecting shaft	e	Y	A
GSZ-2	VWZ-30	6	31	34
Z-5	VWZ-30	9	45	34
Z-5	VWZ-40	7	43	46
Z-5	VWZ-60	2	38	63
Z-10	VWZ-30	12.5	55	34
Z-10	VWZ-40	10.5	53	46
Z-10	VWZ-60	2.5	45	63
Z-25	VWZ-40	28	80.5	46
Z-25	VWZ-60	15	67.5	63
Z-25	VWZ-80	5	57.5	84
Z-35	VWZ-40	28	84	46
Z-35	VWZ-60	15	71	63
Z-35	VWZ-60V*	10	66	73
Z-35	VWZ-80*	5	61	84
Z-50	VWZ-60	17.5	90	63
Z-50	VWZ-60V	12.5	85	73
Z-50	VWZ-80*	7.5	80	84
Z-100	VWZ-60	30	124	63
Z-100	VWZ-60V	25	119	73
Z-100	VWZ-80	20	114	84
Z-150	VWZ-60	30	130	63
Z-150	VWZ-60V	25	125	73
Z-150	VWZ-80	20	120	84
Z-250	VWZ-80	24	144	84
Z-250	VWZ-100	14	134	97
Z-350	VWZ-80	35	175	84
Z-350	VWZ-100	25	165	97
Z-500	VWZ-80	75	240	84
Z-500	VWZ-100	65	230	97

*cannot be fitted with pivot mounts LB

Maximum length - dependent on speed

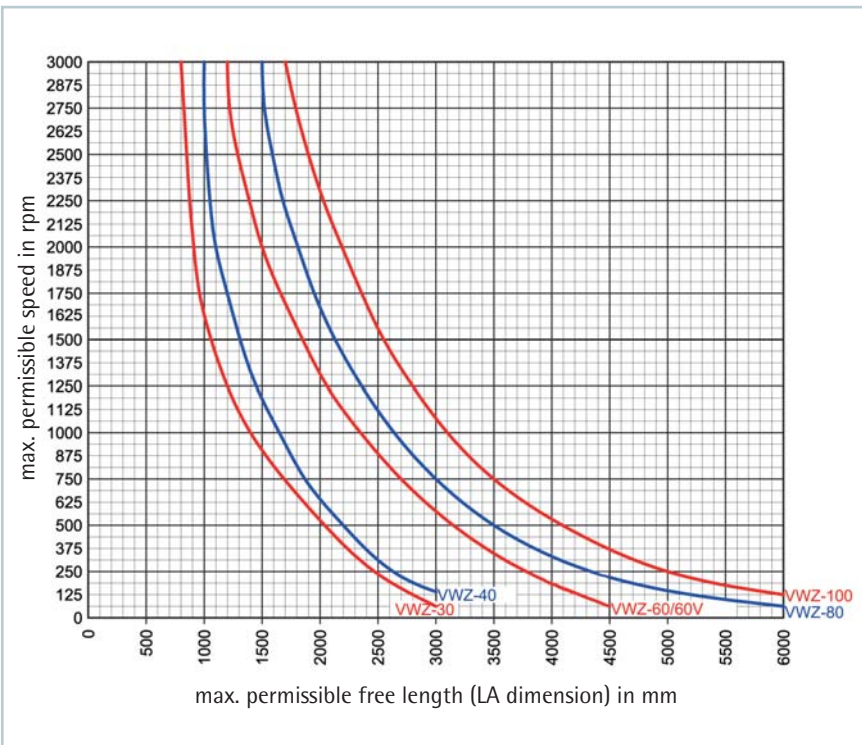

max. permissible offset

Lateral offset:



Kr max. 1.5 mm per 100 mm LI

Angular offset:



max. 2° (1° per coupling)

Axial offset:



ca. +/- 1 bis 2 mm

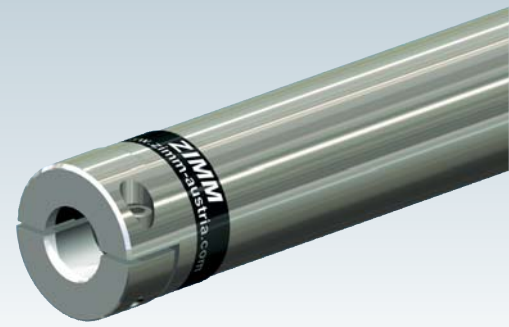

VWZ with rigid hub, for pedestal bearing use

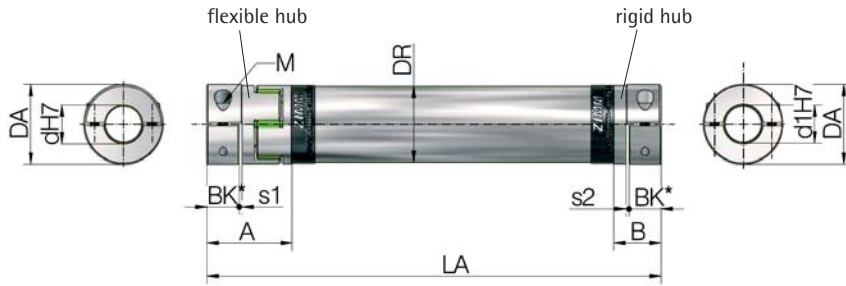

Size	A	B	s1	s2	Bk*	d1	LA min
VWZ-30	34	20	2	1.2	15	15	85
VWZ-40	46	25	2	1.6	17	20	112
VWZ-60	63	40	2	2	30	20	154
VWZ-60V	73	42	2	2	35	30	175
VWZ-80	84	55	2	2	40	30	220
VWZ-100	97	65	2	2	50	50	251

*BK=shaft extension clamping length

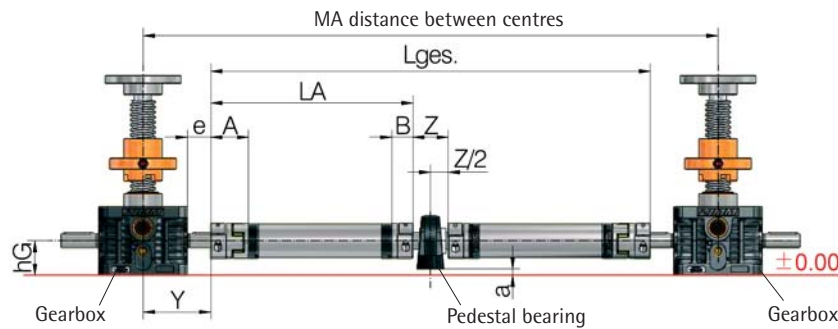
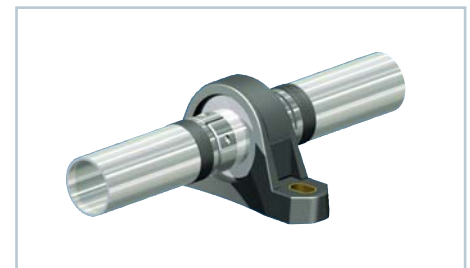

Pedestal bearing: YES/NO?

The installation situation is very important when selecting shaft dimensions. For example, the cost of a larger diameter connecting shaft not requiring additional pedestal bearing support can be considerably less than the cost of a smaller connecting shaft requiring costly sub-structures for the additional pedestal bearing.

For this version we use the rigid hub version so that no radial misalignment can occur in the pedestal bearing.

Gearbox	Connecting shaft	e	Y	A	B	Z	L _{wz}	d1	hG	hL	a
Z-5	VWZ-30	9	45	34	20	44	74	15	31	30.2	0.8
Z-5	VWZ-40	7	43	46	25	42	76	20	31	33.3	-2.3
Z-5	VWZ-60	2	38	63	40	42	102	20	31	33.3	-2.3
Z-10	VWZ-30	12.5	55	34	20	44	74	15	37	30.2	6.8
Z-10	VWZ-40	10.5	53	46	25	42	76	20	37	33.2	3.8
Z-10	VWZ-60	2.5	45	63	40	42	102	20	37	33.2	3.8
Z-25	VWZ-40	28	80.5	46	25	42	76	20	41	33.2	7.8
Z-25	VWZ-60	15	67.5	63	40	42	102	20	41	33.2	7.8
Z-25	VWZ-80	5	57.5	84	55	50	130	30	41	42.9	-1.9
Z-35	VWZ-40	28	84	46	25	42	76	20	50	33.2	16.8
Z-35	VWZ-60	15	71	63	40	42	102	20	50	33.2	16.8
Z-35	VWZ-60V*	10	66	73	42	60	130	30	50	42.9	7.1
Z-35	VWZ-80*	5	61	84	55	50	130	30	50	42.9	7.1
Z-50	VWZ-60	17.5	90	63	40	42	102	20	58	33.3	24.7
Z-50	VWZ-60V	12.5	85	73	42	60	130	30	58	42.9	15.1
Z-50	VWZ-80*	7.5	80	84	55	50	130	30	58	42.9	15.1
Z-100	VWZ-60	30	124	63	40	42	102	20	80	33.2	46.8
Z-100	VWZ-60V	25	119	73	42	60	130	30	80	42.9	37.1
Z-100	VWZ-80	20	114	84	55	50	130	30	80	42.9	37.1
Z-150	VWZ-60	30	130	63	40	42	102	20	92.5	33.2	59.3
Z-150	VWZ-60V	25	125	73	42	60	130	30	92.5	42.9	49.6
Z-150	VWZ-80	20	120	84	55	50	130	30	92.5	42.9	49.6
Z-250	VWZ-80	24	144	84	55	50	130	30	105	42.9	62.1
Z-250	VWZ-100	14	134	97	65	70	170	50	102	57.2	44.8
Z-350	VWZ-80	35	175	84	55	50	130	30	115	42.9	72.1
Z-350	VWZ-100	25	165	97	65	70	170	50	115	57.2	57.8
Z-500	VWZ-80	75	240	84	55	50	130	30	130	42.9	87.1
Z-500	VWZ-100	65	230	97	65	70	170	50	130	57.2	72.8

*cannot be fitted with pivot mounts LB

Ordering example:

VWZ-60-LA1800-25/20S

Size
 Length
 Bore 1st side
 Bore 2nd side (S = rigid hub)

n=1500 rpm (specify the speed)

Pedestal bearing, shaft extension

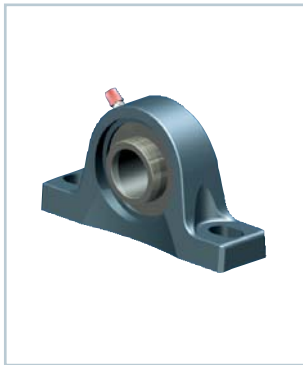

Pedestal bearing STL
for connecting shaft VWZ

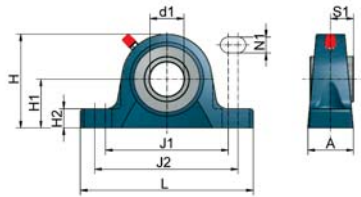

Part no.	d1	A	H	H1	H2	J1	J2	L	N1	S1	kg
STL-15-G	15	32	56	30.2	14	88	106	127	11.5	15.3	0.47
STL-20-G	20	32	65	33.3	14	88	106	127	11.5	18.3	0.59
STL-30-G	30	40	82.5	42.9	17	108	127	152	14	22.2	1.10
STL-40-G	40	48	99	49.2	19	125	146	175	14	30.2	1.85
STL-50-G	50	54	114.5	57.2	22	149	165	203	18	32.6	2.70

We use high-quality pedestal bearings.
Housing material: Grey cast iron, primed in blue
Bearing material: Roller bearing steel
Temperature range: -30°C to +120°C



Pedestal bearings of plastic "black" or "white" (foodstuffs applications) on request.
CAUTION: Dimensions may change!

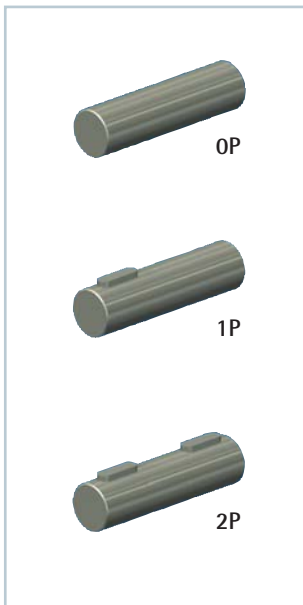
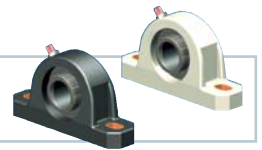

Shaft extension

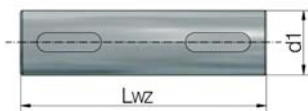

Material: Steel, ground

Part no.	d1	Lwz	kg
WZ-15/74-?P	15	74	0.10
WZ-20/76-?P	20	76	0.19
WZ-20/102-?P	20	102	0.25
WZ-30/130-?P	30	130	0.72
WZ-40/170-?P	40	170	1.67
WZ-50/170-?P	50	170	2.61

Examples:

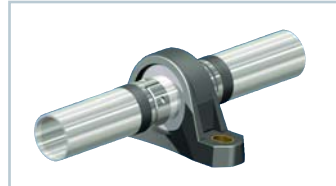

VWZ with rigid hub, for pedestal bearings



Pedestal bearing with handwheel for driving the VWZ shaft

Shaft extension without fitted key (OP)

Shaft extensions with fitted key at one end (1P)



ZIMM VWZ shafts of 500 mm length and more are checked for concentricity as standard!



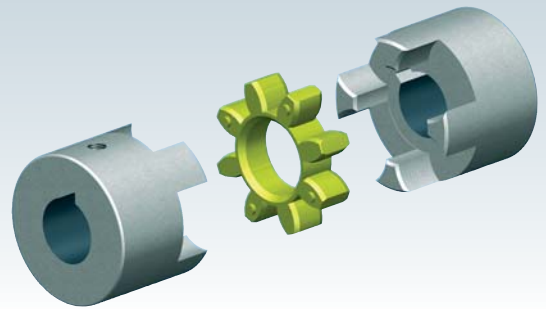

Standard coupling KUZ

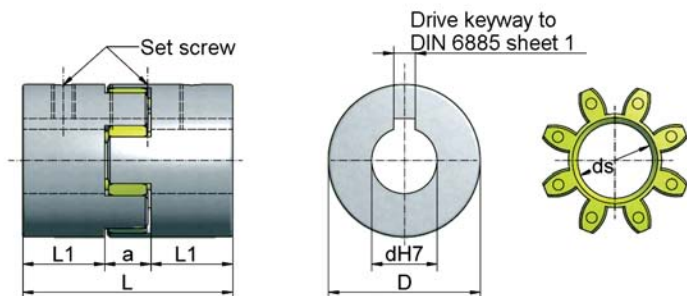

Standard bores "d" [mm]

KUZ-09	U, 5, 6, 7, 8, 9
KUZ-14	U, 9, 11, 14
KUZ-19	U, 11, 14, 16, 19
KUZ-24	U, 11, 14, 16, 19, 19L, 20, 24
KUZ-28	U, 14, 16, 19, 20, 24, 25, 28
KUZ-38	U, 25, 28, 28L, 32, 38
KUZ-45	U, 25, 28, 32, 38, 42, 45
KUZ-55	U, 28, 42, 48, 55

Other diameters available on request
 U = not drilled (KUZ-14 and KUZ-19 pre-drilled $\varnothing 6.3$)
 L = long hub

Dimensions

Size	D	L	L1	a	d _{star}	L1 long hub	Set screw	Tightening torque [Nm]
KUZ-09	20	30	10	10	-		M4	1.5
KUZ-14	27.5	44	16	12	-		M6 (M4)	4.8 (1.5)
KUZ-19	34.5	51	19	13	12		M6	4.8
KUZ-24	40	66	25	16	17	40	M5	2
KUZ-28	55	78	30	18	26		M5	2
KUZ-38	65	90	35	20	29	60	M6	4.8
KUZ-45	80	114	45	24	37		M8	10
KUZ-55	95	126	50	26	45		M8	10
KUZ-60	105	140	56	28	50		M8	10
KUZ-70	120	160	65	30	59		M10	17
KUZ-75	135	185	75	35	67		M10	17
KUZ-90	160	210	85	40	79		M10	17

Coupling with keyway and set screw

- standard coupling with keyway and set screw
- provides rotational resilience
- maintenance-free
- material: as shown in the table

Elastomer star

- material: Polyurethane
- medium to good damping
- very good long-term strength
- temperature range: 0°C to +70°C reduced to -30°C, up to +100°C (Mx0.55)

Technical data

Size	Rated torque [Nm]	max. Torque [Nm]	max. speed [rpm]	Shore hardness Star	Material*	Weight, drilled [kg]	Torsional stiffness C _{dyn} [Nm/rad]	Moment of inertia [10 ⁻³ kgm ²]
KUZ-09	3	6	28000	92A	A	0.05		
KUZ-14	4.5	4.5	20000	55D	S	0.14	254	0.02
KUZ-19	7.3	7.3	14000	55D	S	0.27	274	0.03
KUZ-24	17	34	14000	98A	S	0.34	2920	0.1
KUZ-28	60	120	10600	98A	S	0.9	9930	0.4
KUZ-38	160	320	8500	98A	S	1.5	26770	1.4
KUZ-45	325	650	7100	98A	G	2.35	48570	2.5
KUZ-55	450	900	6000	98A	G	3.55	54500	6.1
KUZ-60	525	1050	5600	98A	G	4.85	65290	10.2
KUZ-70	625	1250	4750	98A	G	7.4	94970	20.3
KUZ-75	900	1300	4250	98A	G	10.8	129510	37.1
KUZ-90	1500	3000	3550	98A	G	17.7	197500	84

* A = Aluminium, S = Sintered steel, G = Cast iron



Ordering example:

KUZ-24-20/24

Size _____
 Bore d end 1 _____
 Bore d end 2 _____

Potential assembly errors

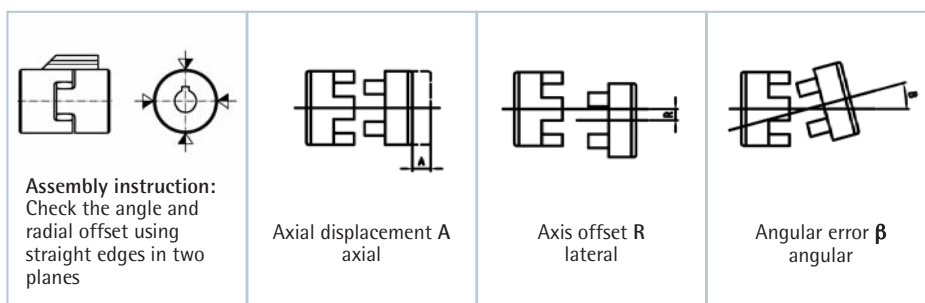

Permissible assembly errors

Size	A	R	β
KUZ-09	0.8	0.15	1.0°
KUZ-14	0.75	0.4	0.5°
KUZ-19	0.75	0.4	0.5°
KUZ-24	1.2	0.2	0.9°
KUZ-28	1.4	0.22	0.9°
KUZ-38	1.5	0.25	0.9°
KUZ-45	1.8	0.28	1.0°
KUZ-55	2	0.32	1.0°
KUZ-60	2.1	0.36	1.1°
KUZ-70	2.2	0.38	1.1°
KUZ-75	2.6	0.42	1.2°
KUZ-90	3	0.48	1.2°

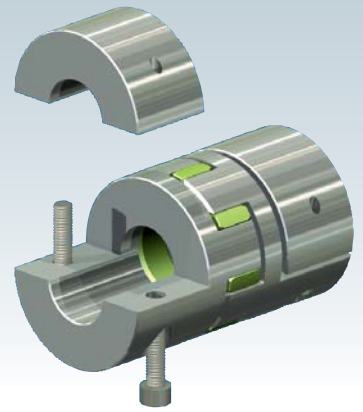

Clamp coupling KUZ-KK

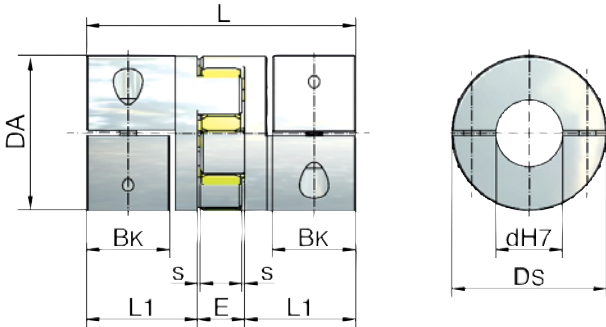

*BK=shaft extension clamping length

Coupling with split shells

- Split shells permit easy radial insertion
- High concentricity
- High clamping forces
- Low moment of inertia
- Stepless adjustment facility thanks to the clamp hub rather than a fitted drive key
- Keyway available on request
- Material: high-tensile aluminium

Standard bores "d" [mm]

KUZ-KK-16	8, 9, 10, 11, 12, 14, 15, 16
KUZ-KK-24	9, 10, 11, 12, 14, 15, 16, 18, 19, 20, 22
KUZ-KK-32	10, 11, 12, 14, 15, 16, 18, 19, 20, 22, 24, 25, 28, 30, 32
KUZ-KK-35	12, 15, 16, 18, 20, 22, 24, 25, 28, 30, 32, 35
KUZ-KK-45	16, 19, 20, 22, 24, 25, 28, 30, 32, 35, 38, 40, 42, 45
KUZ-KK-60	25, 28, 32, 38, 40, 42, 45, 48, 50, 55

Elastomer star

- Permanently free of play, dampens vibration
- Shore hardness 64D
- Colour: ZIMM green
- Temperature range: 0°C to +70°C reduced to -20°C, to +100°C (Mx0.55)

Dimensions, technical data

Coupling size	Dimensions							Clamping screw M	Tightening torque [Nm]	Moment of inertia [10 ⁻³ kgm ²]	Torsional stiffness C _{Tdyn} [Nm/rad]	Weight [kg]
	DA [mm]	DS [mm]	L [mm]	L1 [mm]	BK* [mm]	s [mm]	E [mm]					
KUZ-KK-16	32	32	54	21	15	1.5	12	M4	4	0.01	1375	0.10
KUZ-KK-24	42	44.5	66	25	17	1.5	16	M5	8	0.08	3700	0.20
KUZ-KK-32	56	57	98	40	30	2	18	M6	15	0.24	9917	0.55
KUZ-KK-35	67	68	114	47	35	2	20	M8	35	51	24417	0.90
KUZ-KK-45	82	85	134	55	40	2	24	M10	70	2.4	33667	1.60
KUZ-KK-60	102	105	156	65	50	2	26	M12	120	6	67667	2.70



Ordering example:

KUZ-KK-32-20/24

Size

Bore d end 1

Bore d end 2

Torques

Coupling size	Elastomer star		Maximum transmittable torque of clamp hub depending on the bore diameter (clamp force)																	
	Rated torque [Nm]	Max. torque [Nm]	Ø9 [Nm]	Ø11 [Nm]	Ø14 [Nm]	Ø16 [Nm]	Ø19 [Nm]	Ø20 [Nm]	Ø22 [Nm]	Ø24 [Nm]	Ø25 [Nm]	Ø28 [Nm]	Ø30 [Nm]	Ø32 [Nm]	Ø38 [Nm]	Ø40 [Nm]	Ø42 [Nm]	Ø45 [Nm]	Ø48 [Nm]	Ø55 [Nm]
KUZ-KK-16	12	25	21	26	33	37														
KUZ-KK-24	17	34		41	52	60	70	74	81											
KUZ-KK-32	60	120		60	76	87	104	109	120	131	136	153	164	175						
KUZ-KK-35	160	320				120		188	206		235			301						
KUZ-KK-45	325	650				325	386	406	447	488	508	568	610	650	772		854	915		
KUZ-KK-60	530	1060									570	638		730	866	914	960	1029	1097	1250

1. Axial offset - axial

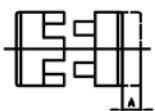

2. Axial offset - lateral

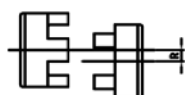

3. Angular error - angular



Size	max. axial offset in mm (axial)	max. axial offset in mm (lateral)	max. angular error in degrees (angular)
KUZ-KK-16	±1	0.08	1°
KUZ-KK-24	±2	0.08	1°
KUZ-KK-32	±2	0.10	1°
KUZ-KK-35	±2	0.15	1°
KUZ-KK-45	±2	0.12	1°
KUZ-KK-60	±2	0.14	1°



Motor flange GSZ-2

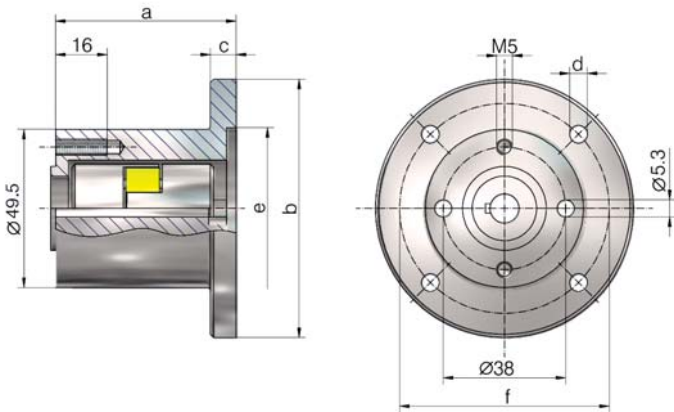

Material: Hard anodised aluminium
Incl. screws**

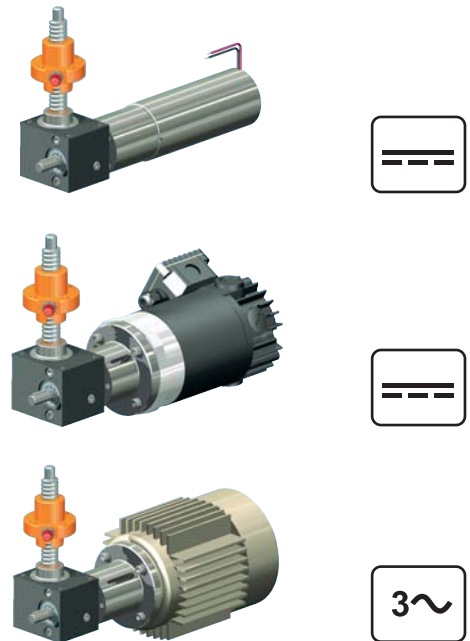

Motor flange Part no.	Motor type	Coupling part no.		2 of screws gearbox side DIN 912 (according to fitting)**	4 of screws motor side DIN 912 incl. spring washers	a	Øb	c	Ød	Øe	Øf	kg
		Size	Bore Ø Gearbox Motor									
GSZ-2-MF-49-51*	Ø53	KUZ-09	- 9 / 6	M5x55, M5x70	M4x30	51	49	-	4.3	25	36	0.19
GSZ-2-MF-80-51	56 B14C	KUZ-09	- 9 / 9	M5x55, M5x70	M5x20	51	80	9	5.5	50	65	0.22
GSZ-2-MF-80-41+P-120-15	63 B14B	KUZ-14	- 9 / 11	M5x55, M5x70, M5x45	M6x25	56	120	15	6.6	80	100	0.55
GSZ-2-MF-80-51+P-105-15	71 B14C	KUZ-14	- 9 / 14	M5x55, M5x70	M6x20	66	105	15	6.6	70	85	0.45

*GSZ-2-MF-49-51 is suitable only for GSZ-2 screw jacks, bevel gearboxes available for KSZ-2 on request

**Screws are included for all the various fitting options

Fitting options

(Motor flanges are suitable for screw jacks and for bevel gearboxes)

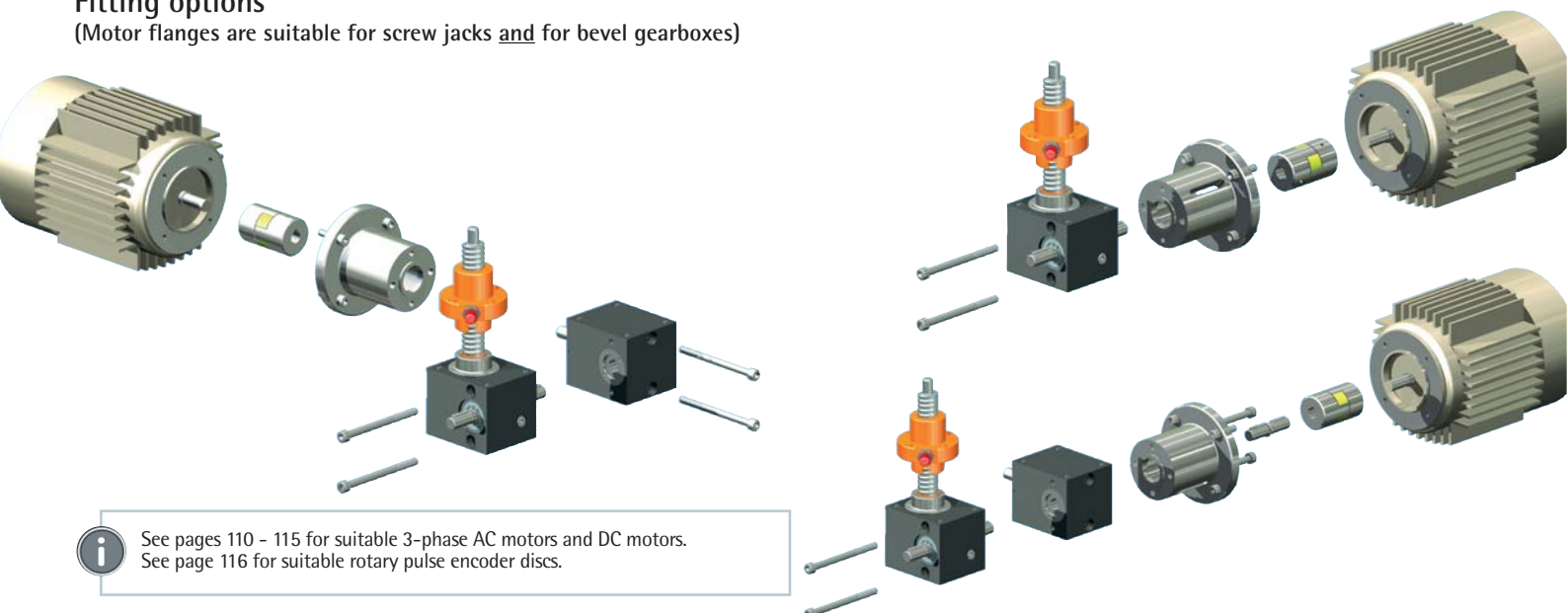

See pages 110 - 115 for suitable 3-phase AC motors and DC motors.
See page 116 for suitable rotary pulse encoder discs.

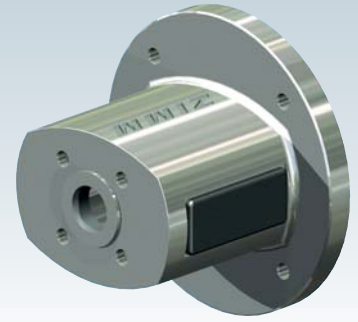

Motor flange Z-5 to Z-25

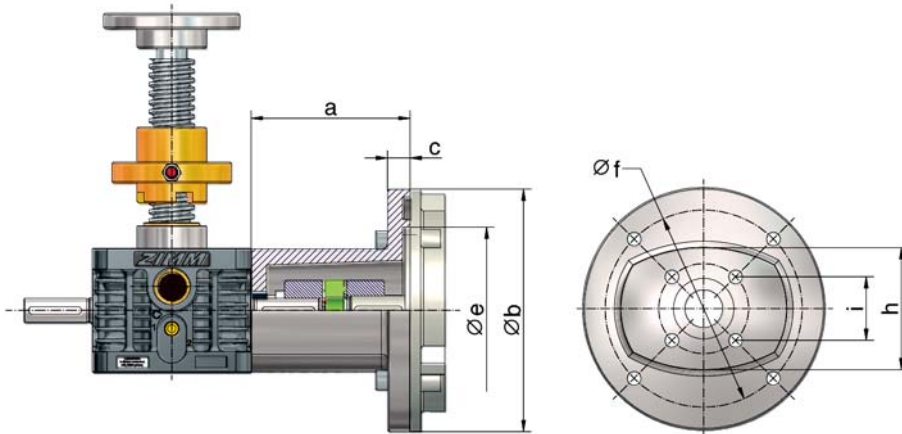

Material: Aluminium
Incl. screws

Motor flange Part no.	Motor type	Coupling part no.		4 of screws gearbox side 8.8	4 of socket head cap screws 8.8 DIN 912 for motor	a	b	c	e	f	h	i	kg
		Size	Bore Ø										
Z-5-MF-120-60	63 B14B	KUZ-14	- 11 / 11	M6x12 - DIN 7991	M6x20 + spring washers	60	120	10	80	100	61	32.5	0.33
Z-5-MF-105-68	71 B14C	KUZ-19	- 11 / 14	M6x12 - DIN 7991	M6x20 + spring washers	68	105	10	70	85	61	32.5	0.31
Z-10-MF-120-66	63 B14B	KUZ-19	- 14 / 11	M8x16 - DIN 7991	M6x20 + spring washers	66	120	10	80	100	73	35.4	0.42
Z-10-MF-160-75	71 B5	KUZ-19	- 14 / 14	M8x16 - DIN 7991	M8x35 + nuts	75	160	15	110	130	73	35.4	0.81
Z-10-MF-160-90	80 B14B	KUZ-24	- 14 / 19	M8x16 - DIN 7991	M8x30 + spring washers	90	160	15	110	130	73	35.4	0.88
Z-25-MF-160-105	71 B5	KUZ-28	- 16 / 14	M8x20 - DIN 7991	M8x35 + nuts	105	160	15	110	130	81	42	1.11
Z-25-MF-160-105	80 B14B	KUZ-24	- 16 / 19	M8x20 - DIN 7991	M8x30 + spring washers	105	160	15	110	130	81	42	1.11
Z-25-MF-160-105	90 B14B	KUZ-24	- 16 / 24	M8x20 - DIN 7991	M8x30 + spring washers	105	160	15	110	130	81	42	1.11
Z-25-MF-160-122	100 B14C	KUZ-28	- 16 / 28	M8x20 - DIN 7991	M8x30 + spring washers	122	160	15	110	130	81	42	1.25

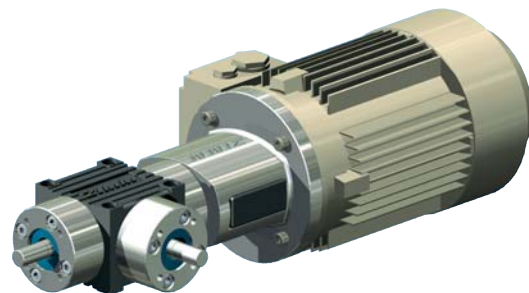
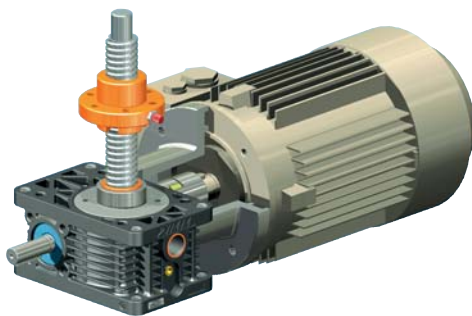

i Motor flange for Z-5 to Z-50 are also suitable for bevel gearboxes KSZ and KGZ.

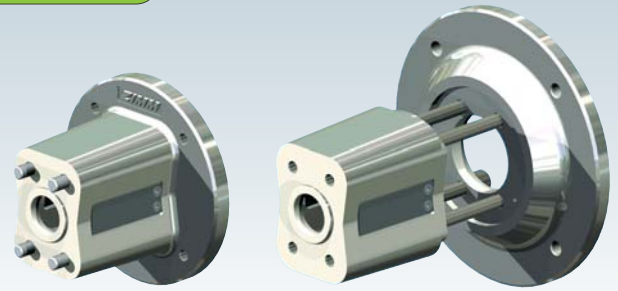

Motor flange for Z-35 to Z-150

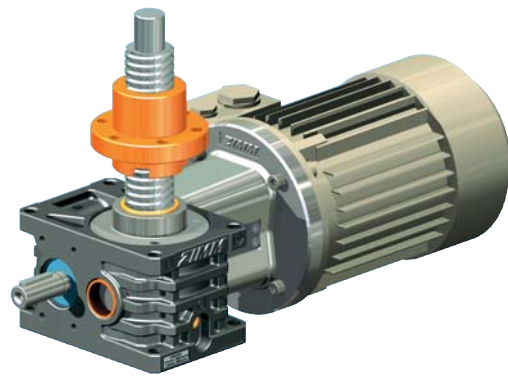
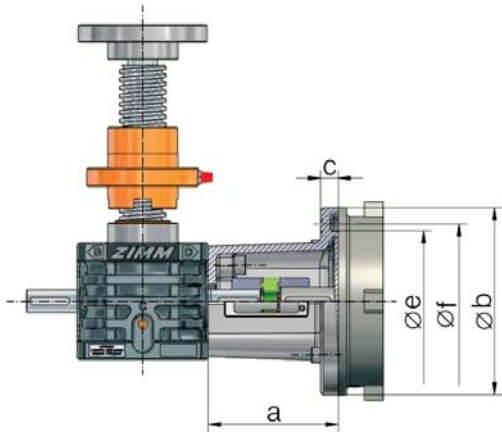

Motor flange (one-piece)

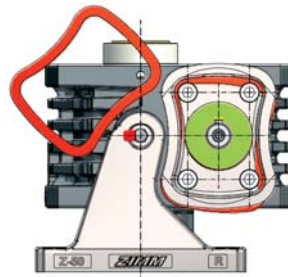
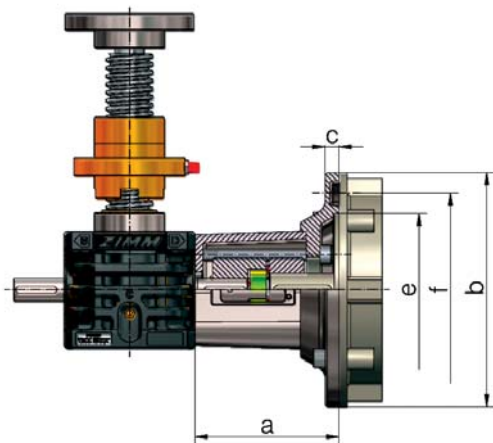

Motor flange base + motor flange plate



Material: GGG-50, corrosion-resistant
Incl. screws

Motor flange Part no. 	Motor type	Coupling part no. 		4 of screws gearbox side DIN 912	4 of screws motor side DIN 912	a	b	c	e	f	kg
		Size	Bore Ø Gearbox Motor								
Z-35-MF-160-111	80 B14B	KUZ-24	- 19 / 19	M10x30	M8x25 ¹⁾	111	160	15	110	130	2.6
Z-35-MF-160-111	90 B14B	KUZ-24	- 19 / 24	M10x30	M8x25 ¹⁾	111	160	15	110	130	2.6
Z-35-MF-B + Z-35-MF-P-200	100 B14B	KUZ-28	- 19 / 28	M10x120	M10x30 ¹⁾	123	200	12	130	165	3.6
Z-35-MF-B + Z-35-MF-P-200	112 B14B	KUZ-28	- 19 / 28	M10x120	M10x30 ¹⁾	123	200	12	130	165	3.6
Z-35-MF-B + special plate	servomotors, geared motors, Nema motors,...										
Z-50-MF-200-116	90 B5	KUZ-28	- 20 / 24	M10x30	M10x45 ²⁾	116	200	20	130	165	4.1
Z-50-MF-200-126	100 B14B	KUZ-28	- 20 / 28	M10x30	M10x35 ¹⁾	126	200	20	130	165	4.3
Z-50-MF-200-126	112 B14B	KUZ-28	- 20 / 28	M10x30	M10x35 ¹⁾	126	200	20	130	165	4.3
Z-50-MF-B + special plate	servomotors, geared motors, Nema motors,...										
Z-100/150-MF-200-138	100 B14B	KUZ-28	- 25 / 28	M12x40	M10x35 ¹⁾	138	200	20 ³⁾	130	165	5.2
Z-100/150-MF-200-138	112 B14B	KUZ-28	- 25 / 28	M12x40	M10x35 ¹⁾	138	200	20 ³⁾	130	165	5.2
Z-100/150-MF-B + P-200	132 B14C	KUZ-38	- 25 / 38	M12x150	M10x65 ¹⁾	161	200	48 ³⁾	130	165	8.7
Z-100/150-MF-B + special plate	servomotors, geared motors, Nema motors,...										

¹⁾ incl. spring washers

²⁾ incl. nuts

³⁾ for GSZ +6 mm (plate)

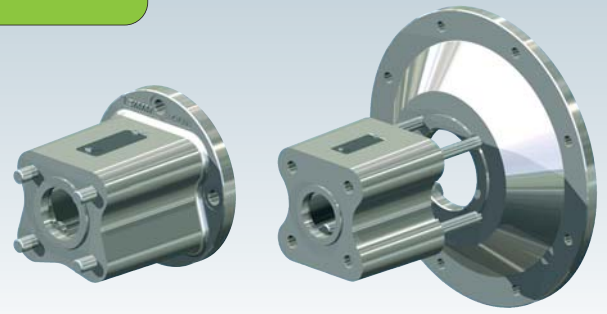

Motor flange Z-250 to Z-1000

Motor flange (one-piece)

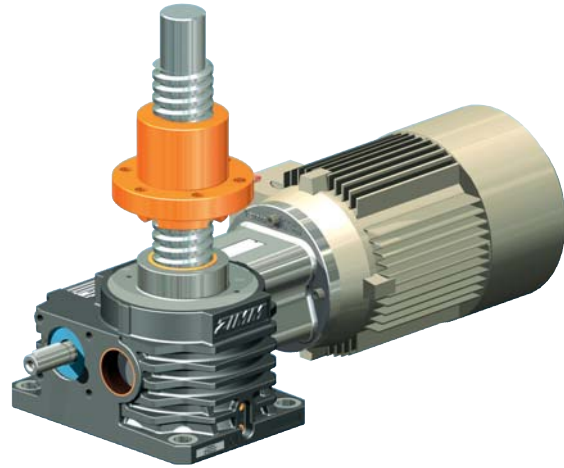
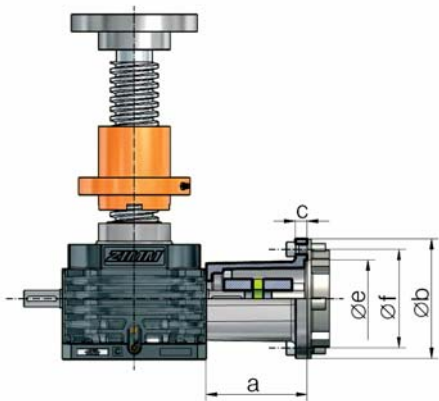

Motor flange base + motor flange plate

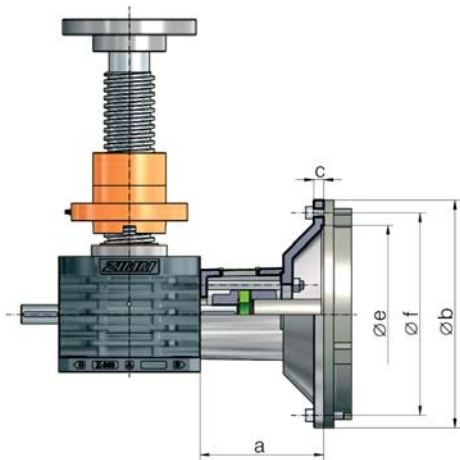

Material: GGG-50, corrosion-resistant
Incl. screws

Motor flange Part no.	Motor type	Coupling part no.		4 of screws gearbox side DIN 912	4 of screws motor side DIN 912	a	b	c	e	f	kg
		Size	Bore \varnothing Gearbox Motor								
Z-250-MF-200-168	100 B14B	KUZ-38	- 28L / 28L	M16x55	M10x40 ¹⁾	168	200	20	130	165	8.5
Z-250-MF-200-168	112 B14B	KUZ-38	- 28L / 28L	M16x55	M10x40 ¹⁾	168	200	20	130	165	8.5
Z-250-MF-200-168	132 B14C	KUZ-38	- 28 / 38	M16x55	M10x40 ¹⁾	168	200	20	130	165	8.5
Z-250-MF-200-168 + P-350	160 B5	KUZ-45	- 28 / 42	M16x55	M16x70 ²⁾	198	350	30	250	300	20.5
Z-250-MF-200-168 + P-350	180 B5	KUZ-55	- 28 / 48	M16x55	M16x70 ²⁾	198	350	30	250	300	20.5
Z-250-MF-200-168 + P-400	200 B5	KUZ-55	- 28 / 55	M16x55	M16x70 ²⁾	200	400	32	300	350	25
Z-250-200-168 -MF-B + special plate	servomotors, geared motors, Nema motors,...										
Z-350-MF-B + P-350	180 B5	KUZ-55	- 38 / 48	4x M18 ³⁾	M16x60 ²⁾	211	350	19	250	300	24
Z-350-MF-B + P-400	200 B5	KUZ-55	- 38 / 55	4x M18 ³⁾	M16x60 ²⁾	211	400	19	300	350	27
Z-350-MF-B + P-450	225 B5	KUZ-60	- 38 / 60 ⁴⁾	4x M18 ³⁾	M16x60 ²⁾ (8x)	245	450	19	350	400	33
Z-350-MF-B + special plate	servomotors, geared motors, Nema motors,...										
Z-500-MF-B + P-400	200 B5	KUZ-55	- 40 / 55	5x M20 ³⁾	M16x60 ²⁾	251	400	19	300	350	32
Z-500-MF-B + P-450	225 B5	KUZ-60	- 40 / 60 ⁴⁾	5x M20 ³⁾	M16x60 ²⁾ (8x)	285	450	19	350	400	40
Z-500-MF-B + P-550	250 B5	KUZ-70	- 40 / 65 ⁴⁾	5x M20 ³⁾	M16x70 ²⁾ (8x)	285	550	21	450	500	55
Z-500-MF-B + special plate	servomotors, geared motors, Nema motors,...										

¹⁾ incl. spring washers

²⁾ incl. nuts and spring washers

³⁾ set screws 8.8 with nuts and spring washers

⁴⁾ from size 225 check the shaft diameter, it can vary depending on the motor (these diameters should be suitable for 4, 6 and 8-pole motors)



Motor flange for Z-750 and Z-1000 on request

Overview

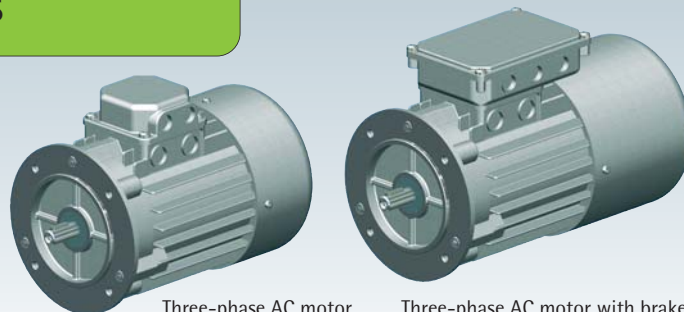
Three-phase AC motor

Three-phase AC motor with brake

Three-phase AC motors, three-phase AC motors with brakes

Standard three-phase motors (asynchronous)
 No-load speed ~ 1500 rpm (other speeds on request)
 230/400 V Δ 50 Hz, S1 or S3-75%, ISO F
 Three-phase AC motors: IP 55
 Three-phase AC motors with brakes: IP 54

Voltage ranges

220 - 240 V Δ 50 Hz

380 - 415 V Δ 50 Hz

440 - 480 V Δ 60 Hz

380 - 415 V Δ 50 Hz

660 - 690 V Δ 50 Hz

440 - 480 V Δ 60 Hz

Frame size	Power	Rated speed	Rated torque	Rated current at 400 V	for direct-on-line starting		Breakdown torque to rated torque	Moment of inertia J	Efficiency (at 100% load)	Power factor (at 100% load)	Weight without brake	Weight with brake
					Starting current to rated current	Starting torque to rated torque						
IEC	kW	rpm	Nm	A	I _A /I _N	M _A /M _N	M _k /M _N	approx. kgm ²	η %	cos	approx. kg	approx. kg
56	0.09	1300	0.66	0.35	2.5	1.8	2.0	0.0002	50.0	0.76	2.7	4.0
63	0.18	1330	1.30	0.65	2.3	1.9	1.9	0.0003	58.0	0.70	4.1	6.0
63	0.25*	1340	1.81	0.94	2.2	1.7	2.5	0.0004	60.0	0.76	4.2	6.5
71	0.37	1360	2.60	1.2	2.8	2.0	2.0	0.0008	63.0	0.70	6.0	8.0
71	0.75*	1370	5.33	2.1	2.9	2.1	2.4	0.0012	69.0	0.78	8.3	10.3
80	0.75	1410	5.10	2.0	4.5	2.2	2.8	0.0020	70.0	0.70	9.3	13.0
80	1.5*	1390	10.4	3.4	4.1	3.2	3.2	0.0026	72.0	0.70	11.5	15.2
90L	1.5	1410	10.3	3.7	4.9	3.0	3.0	0.0032	79.0	0.74	14.4	18.0
90L	2.2*	1400	15.2	5.2	4.5	2.7	2.7	0.0039	78.0	0.81	17.5	21.1
100L	2.2	1420	14.8	5.3	4.0	2.3	2.7	0.0046	83.0	0.74	19.2	25.5
100L	3.0	1410	20.3	6.7	3.9	2.3	2.5	0.0056	82.0	0.79	22.4	28.0
100L	4.0*	1420	27.0	8.9	4.0	2.2	2.2	0.0065	81.0	0.82	26.3	31.9
112M	4.0	1440	27.0	9.4	3.3	2.5	2.9	0.0133	83.0	0.75	30.4	38.0
112M	5.5*	1440	36.4	11.7	3.9	2.1	2.3	0.0139	84.0	0.83	33.0	40.6
132S	5.5	1440	36.0	12.0	5.8	3.0	3.0	0.0224	83.0	0.80	41.9	56.0
132M	7.5	1440	50.0	15.4	6.8	3.1	3.1	0.0293	86.0	0.82	51.0	66.0
132M	11*	1445	73.1	24.5	8.2	3.5	3.5	0.0458	83.0	0.80	74.0	89.0
160M	11	1460	72.1	20.7	7.6	2.1	2.4	0.0832	89.1	0.86	101.0	111.0
160L	15	1460	96.2	29.2	7.1	2.4	2.6	0.1506	89.4	0.83	110.0	120.0
180M	18.5	1465	119.0	34.3	7.1	2.3	2.6	0.1773	90.4	0.86	135.0	150.0
180L	22	1475	142.0	41.1	6.9	2.4	2.6	0.2936	90.9	0.85	145.0	160.0
200L	30	1475	190.0	54.0	6.6	2.1	2.3	0.6345	92.1	0.87	230.0	253.0
225S	37	1470	238.0	64.7	7.0	2.3	2.5	0.3251	92.8	0.89	338.0	361.0
225M	45	1470	286.0	77.9	7.4	2.3	2.4	0.7866	92.6	0.90	358.0	381.0
250M	55	1465	359.0	94.0	7.5	2.6	2.6	0.9483	93.4	0.90	482.0	517.0
250ML	75	1480	484.0	134.0	6.3	1.2	2.2	0.9988	94.0	0.80	535.0	570.0
280S	75	1475	476.0	136.0	6.8	2.1	2.5	1.8495	93.5	0.85	591.0	631.0
280M	90	1485	591.0	167.0	8.3	2.5	2.9	2.2306	93.6	0.85	662.0	702.0
280ML	110	1480	710.0	190.0	6.9	2.7	3.1	2.6800	94.0	0.89	750.0	790.0
315S	110	1485	709.0	199.0	7.5	2.3	2.5	2.8136	93.9	0.85	867.0	940.0
315M	132	1480	830.0	229.0	7.5	2.4	2.6	3.3435	94.7	0.88	990.0	1063.0
315M	160	1485	1040.0	277.0	7.3	2.7	2.7	3.3435	94.7	0.88	1003.0	1076.0
315M	200	1485	1277.0	349.0	7.6	2.4	2.6	3.3435	95.0	0.87	1003.0	1076.0
355M	250	1475	1619.0	432.0	7.5	2.4	2.5	5.8740	95.0	0.88	1380.0	1490.0
355M	315	1485	2024.0	542.0	6.9	2.5	2.6	6.8900	95.3	0.88	1600.0	1790.0

*Power is higher than the IEC standard (progressive)



Sizes 63 to 132 available on short lead times
 Sizes 160 to 355 available on request

CAUTION:

Overdimensioning the motor power risks overstressing other components. The effects must be considered not only under load but also for the no-load case.

We supply motor brakes as standard for a connection voltage of 230V AC, operating voltage 205 V DC, with bridge rectifiers.



Ordering example:

90-P4-1.5-B5-B-2W

Size
 Number of poles - speed
 4-pole = 1500 rpm
 Power [kW]
 Design
 with brake (if required)
 with a second shaft end (if required)

Three-phase AC motors, general information

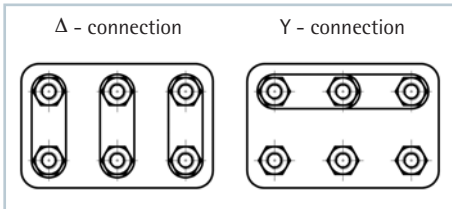

Connection arrangement

The motors usually have a terminal board with 6 terminals and a protective earth terminal in the terminal box. The stator winding can be switched into star or delta connection using the connection links.

Star/delta starting is not suitable for screw jack systems because full torque is required immediately on starting.

Operating voltage 230 V delta:

Motor windings 230/400 V

Operating voltage 400 V delta:

Motor windings 400/660 V

Direction of rotating

Motors can be arranged for either direction of rotation. When the line phases L1, L2, L3 are connected to the motor terminals U1, V1, W1, the direction of rotation is clockwise.

Swapping over two of the supply lines reverses the direction of rotation.

Speeds

Three-phase AC motors have different rotational speeds depending on the number of poles. Generally we recommend our standard motor with 1500 rpm (4 poles).

Other numbers of poles are available on request. Pole-changing motors allow a choice of 2 different rotational speeds.

Speed (50 Hz)	Number of poles
3000	2
1500	4 (= preferred type)
1000	6
750	8
500	12

Geared motors

Geared motors are available for particular projects on request.

Operation with frequency converters

Especially for larger screw jacks and systems, we recommend the use of a frequency converter to achieve smooth start-up and brake ramps. This minimizes start-up noise and extends the service life of the gearbox.

When operating with a frequency converter, remember that if the motor is to be operated for extended periods at frequencies less than 25 Hz, its fan must be driven separately. This is necessary to ensure adequate motor cooling.

When operating a braked motor with a frequency converter, a separate actuation line for the brake must be provided via the frequency converter.

Braked motor

We recommend using a braked motor to minimise the overrun time of the system. Where a screw jack is fitted with a ball screw or a double-pitch screw, a braked motor is absolutely essential. We supply motor brakes as standard for a connection voltage of 230V AC / operating voltage 205 V DC, with bridge rectifiers.

Other connection voltages (24V DC, 400V AC, 500V AC) are available on request.

Temperature monitoring

Generally we do not supply temperature monitoring because screw jack duty cycles are normally quite low or the motor is adequately dimensioned.

Temperature control thermal resistor (PTC) or bimetal (TKÖ) is available on request.

Some types are available ex stock with thermal resistor (PTC).

Permanent-magnet DC motors



24V DC, IP 54, with terminal box

Frame size IEC	Power [P]	Speed [rpm]	Rated torque*** [Nm]	Starting torque [Nm]	Voltage [V]	Rated current [A]	Motor length (without shaft)	Weight [kg]
Ø53	60W	3000	0.17	1.4	24V DC	2.9	128	1.2
56, B14C Ø80	85W	1500**	0.53	1.5	24V DC	4.5	149*	2.7
56, B14C Ø80	165W	1500**	1.0	3.0	24V DC	8.8	196*	4.3
56, B14C Ø80	250W	1500**	1.6	4.5	24V DC	13.5	241*	5.6

*Optional brake available (24V DC, 13W, 2 Nm, 1.1 kg), + 44 mm length

** 3000 rpm motor available on request, torque remains the same

*** Short-term operation at twice the torque is possible



Other sizes available on request

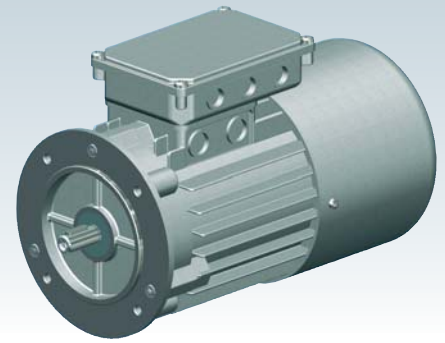

Three-phase AC motors, three-phase AC motors with brakes, flange profile B14B, large flange

B14: Flange with internal thread
B: Large flange

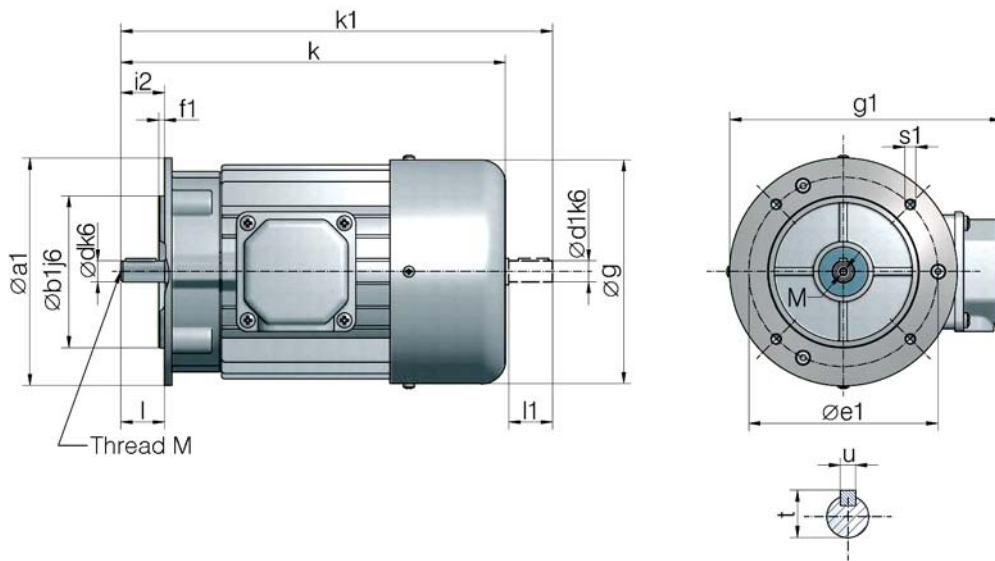

We reserve the right to change the dimensions without changing the motor designation.

Size	a1	b1	e1	f1	g	i2	s1	d	l	t	u
63	120	80	100	3.0	125	23	M6	11	23	12.5	4
71	140	95	115	3.0	141	30	M8	14	30	16.0	5
80	160	110	130	3.5	159	40	M8	19	40	21.5	6
90	160	110	130	3.5	179	50	M8	24	50	27.0	8
100	200	130	165	3.5	199	60	M10	28	60	31.0	8
112	200	130	165	3.5	223	60	M10	28	60	31.0	8

These dimensions are standardised and thus always remain the same.

Size	kW (4-pole)	without brake				with brake		with brake and second shaft end				M
		k	k1	d1	l1	k	k	k1	d1	l1	g1	
63	0.18	212	238	11	23	261	261	285	9	20	172	4
63	0.25	212	238	11	23	239	261	285	9	20	172	4
71	0.37	248	281	14	30	263	295	325	11	23	188	5
71	0.75	248	281	14	30	263	295	325	11	23	188	5
80	0.75	277	315	19	40	310	330	375	19	40	211	6
80	1.5	277	315	19	40	310	330	375	19	40	211	6
90	1.5	329	378	24	50	390	390	432	19	40	227	8
90	2.2	329	378	24	50	348	390	432	19	40	227	8
100	3.0	369	429	28	60	451	451	487	24	50	248	10
100	4.0	369	429	28	60	451	451	487	24	50	248	10
112	5.5	391	448	28	60	456	456	511	24	50	266	10

These dimensions are our standard (4-pole), but may vary in individual cases.

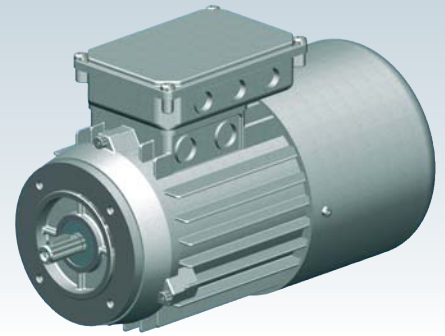

Three-phase AC motors, three-phase AC motors with brakes, flange profile B14C, small flange

B14: Flange with internal thread
C: Small flange

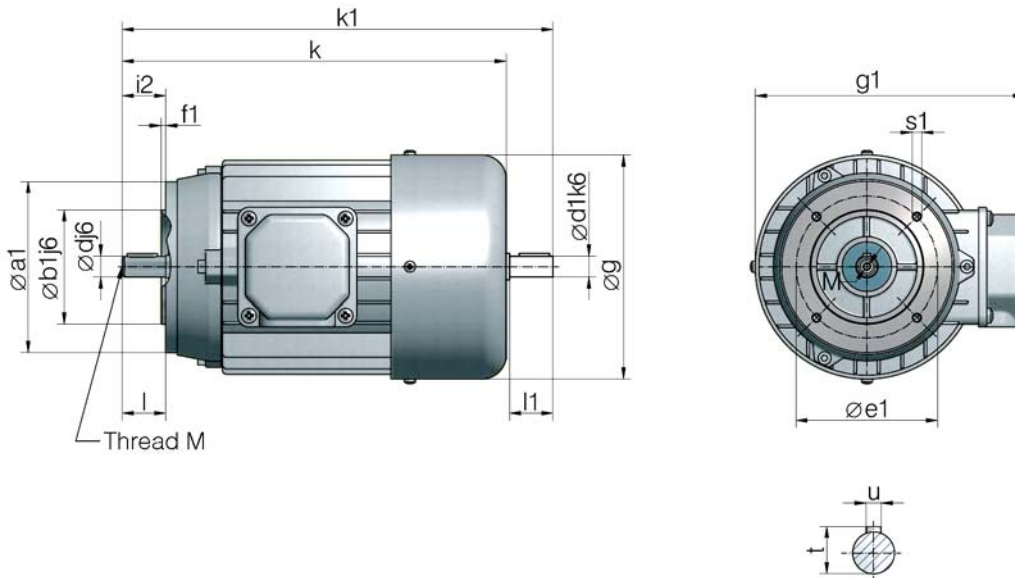

We reserve the right to change the dimensions without changing the motor designation.

Size	a1	b1	e1	f1	g	i2	s1	d	l	t	u
56	80	50	65	2.5	110	20	M5	9	20	10.2	3
63	90	60	75	2.5	125	23	M5	11	23	12.5	4
71	105	70	85	2.5	141	30	M6	14	30	16.0	5
80	120	80	100	3.0	159	40	M6	19	40	21.5	6
90	140	95	115	3.0	179	50	M8	24	50	27.0	8
100	160	110	130	3.5	199	60	M8	28	60	31.0	8
112	160	110	130	3.5	223	60	M8	28	60	31.0	8
132	200	130	165	4.0	258	80	M10	38	80	41.0	10

These dimensions are standardised and thus always remain the same.

Size	kW (4-pole)	without brake				with brake	with brake and second shaft end				q1	M
		k	k1	d1	l1	k	k	k1	d1	l1		
56	0.09	189	212	9	20	243	243				161	4
63	0.18	212	238	11	23	261	261	285	9	20	172	4
63	0.25	212	238	11	23	239	261	285	9	20	172	4
71	0.37	248	281	14	30	263	295	325	11	23	188	5
71	0.75	248	281	14	30	263	295	325	11	23	188	5
80	0.75	277	315	19	40	310	330	375	19	40	211	6
80	1.5	277	315	19	40	310	330	375	19	40	211	6
90	1.5	329	378	24	50	390	390	432	19	40	227	8
90	2.2	329	378	24	50	348	390	432	19	40	227	8
100	3.0	369	429	28	60	451	433	487	24	50	248	10
100	4.0	369	429	28	60	451	433	487	24	50	248	10
112	5.5	391	448	28	60	456	456	511	24	50	266	10
132	7.5	490	570	38	80	585					326	12

These dimensions are our standard (4-pole), but may vary in individual cases.

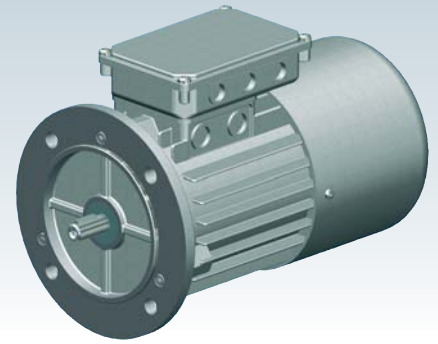

Three-phase AC motors, three-phase AC motors with brakes, flange profile B5

B5: Flange with through holes

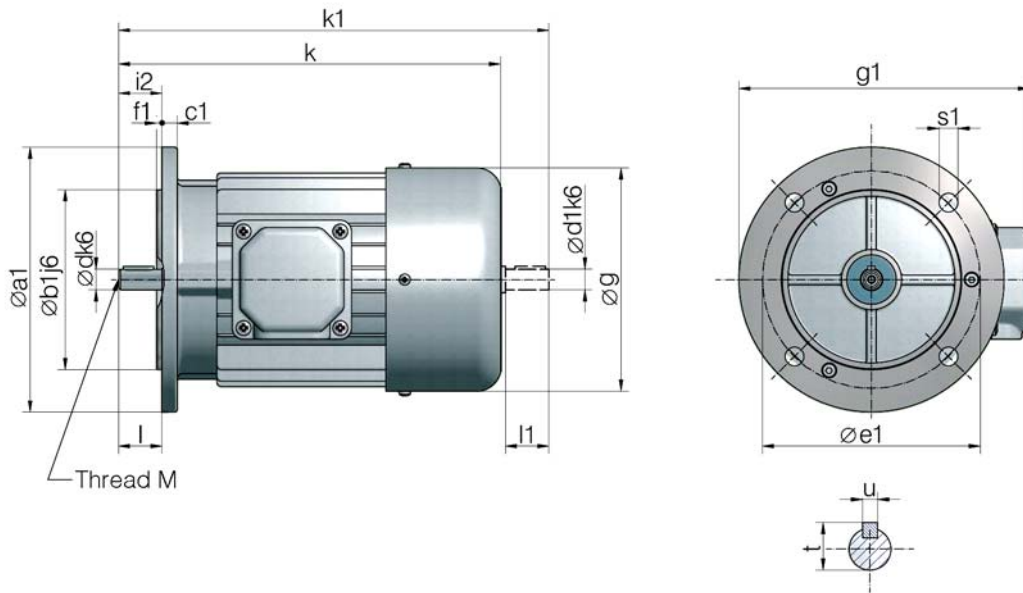

We reserve the right to change the dimensions without changing the motor designation.

Size	a1	b1	c1	e1	f1	g	i2	s1	d	l	t	u
63	140	95	5	115	3.0	125	23	9.5	11	23	12.5	4
71	160	110	7	130	3.5	141	30	9.5	14	30	16.0	5
80	200	130	8	165	3.5	159	40	11.5	19	40	21.5	6
90	200	130	8	165	3.5	179	50	11.5	24	50	27.0	8
100	250	180	10	215	4.0	199	60	14	28	60	31.0	8
112	250	180	10	215	4.0	223	60	14	28	60	31.0	8

These dimensions are standardised and thus always remain the same.

Size	kW	without brake				with brake	with brake and second shaft end				g1	M
		k	k1	d1	l1	k	k	k1	d1	l1		
63	0.18	212	238	11	23	261	261	285	9	20	172	4
63	0.25	212	238	11	23	239	261	285	9	20	172	4
71	0.37	248	281	14	30	263	295	325	11	23	188	5
71	0.75	248	281	14	30	263	295	325	11	23	188	5
80	0.75	277	315	19	40	310	330	375	19	40	211	6
80	1.5	277	315	19	40	310	330	375	19	40	211	6
90	1.5	329	378	24	50	390	390	432	19	40	227	8
90	2.2	329	378	24	50	348	390	432	19	40	227	8
100	3.0	369	429	28	60	451	433	487	24	50	248	10
100	4.0	369	429	28	60	451	433	487	24	50	248	10
112	5.5	391	448	28	60	456	456	511	24	50	266	10

These dimensions are our standard (4-pole), but may vary in individual cases.

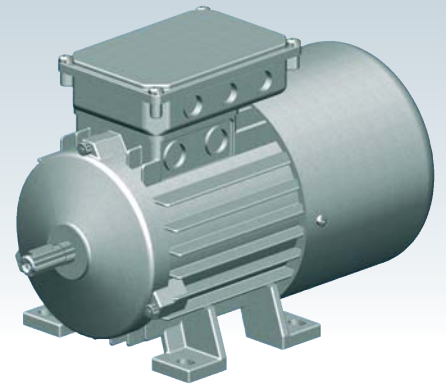

Three-phase AC motors, three-phase AC motors with brakes, pedestal mounted type B3

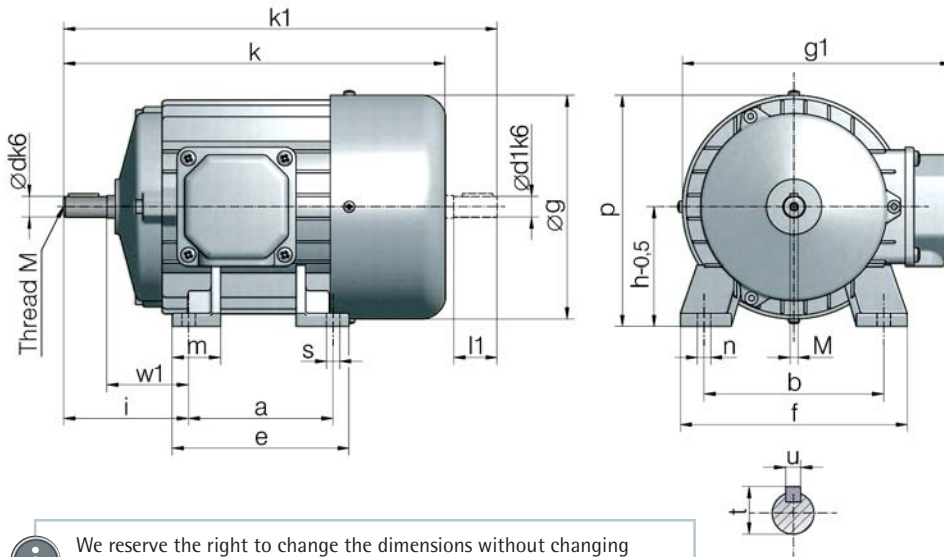

For this type, we can supply a flanged motor (e.g.: B14) with additional pedestal mounts fitted. This version is generally available on a shorter lead time. The dimensions remain the same.

Please specify the terminal box position (top, right or left when looking at the motor shaft). If not otherwise specified, we deliver up to size 112 with the box on top and from size 132 with it on the right.

i We reserve the right to change the dimensions without changing the motor designation.

Size	a	b	g	h	i	p*	s	n	w1	d	l	t	u
63	80	100	125	63	63	126	7	11	40	11	23	12.5	4
71	90	112	141	71	75	142	7	7	45	14	30	16.0	5
80	100	125	159	80	90	160	9	17	50	19	40	21.5	6
90	125	140	179	90	106	180	9	17	56	24	50	27.0	8
100	140	160	199	100	123	200	12	20	63	28	60	31.0	8
112	140	190	223	112	130	224	12	21	70	28	60	31.0	8
132S	140	216	262	132	169	264	12		89	38	80	41.0	10
132M	178	216	262	132	169	264	12		89	38	80	41.0	10
160M	210	254	318	160	218	320	14		108	42	110	45.0	12
160L	254	254	318	160	218	320	14		108	42	110	45.0	12
180M	241	279	358	180	231	360	14		121	48	110	51.5	14
180L	279	279	358	180	231	360	14		121	48	110	51.5	14
200L	305	318	398	200	243	400	19		133	55	110	59.0	16

These dimensions are standardised and thus always remain the same.

* The height g1 is for top-mounted terminal boxes

Size	kW	without brake				with brake	with brake and second shaft end				c	e	f	g1	M
		k	k1	d1	l1	k	k1	d1	l1						
63	0.18	212	238	11	23	261	261	285	9	20	10	105	120	172	4
63	0.25	212	238	11	23	239	261	285	9	20	10	105	120	172	4
71	0.37	248	281	14	30	263	295	325	11	23	11	108	136	188	5
71	0.75	248	281	14	30	263	295	325	11	23	11	108	136	188	5
80	0.75	277	315	19	40	310	330	375	19	40	11	125	154	211	6
80	1.5	277	315	19	40	310	330	375	19	40	11	125	154	211	6
90	1.5	329	378	24	50	390	390	432	19	40	13	155	174	227	8
90	2.2	329	378	24	50	348	390	432	19	40	13	155	174	227	8
100	3.0	369	429	28	60	451	433	487	24	50	14	175	192	248	10
100	4.0	369	429	28	60	451	433	487	24	50	14	175	192	248	10
112	5.5	391	448	28	60	456	456	511	24	50	14	175	224	266	10
132S	5.5	452				547					16	180	256	326	12
132M	7.5	490				585					16	219	256	326	12
160M	11.0	608									23	264	320	395	16
160L	15.0	652									23	306	320	395	16

These dimensions are our standard (4-pole), but may vary in individual cases.

Rotary pulse encoder DIG incremental

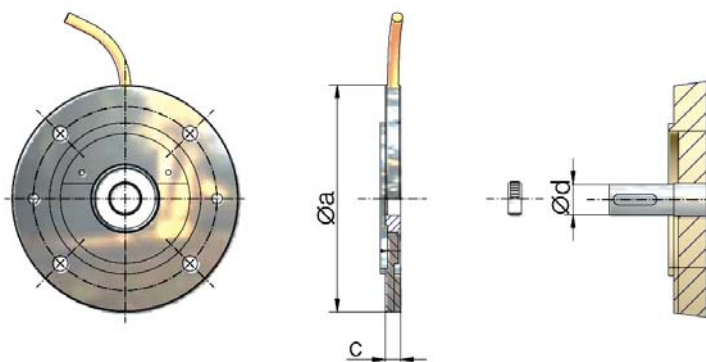
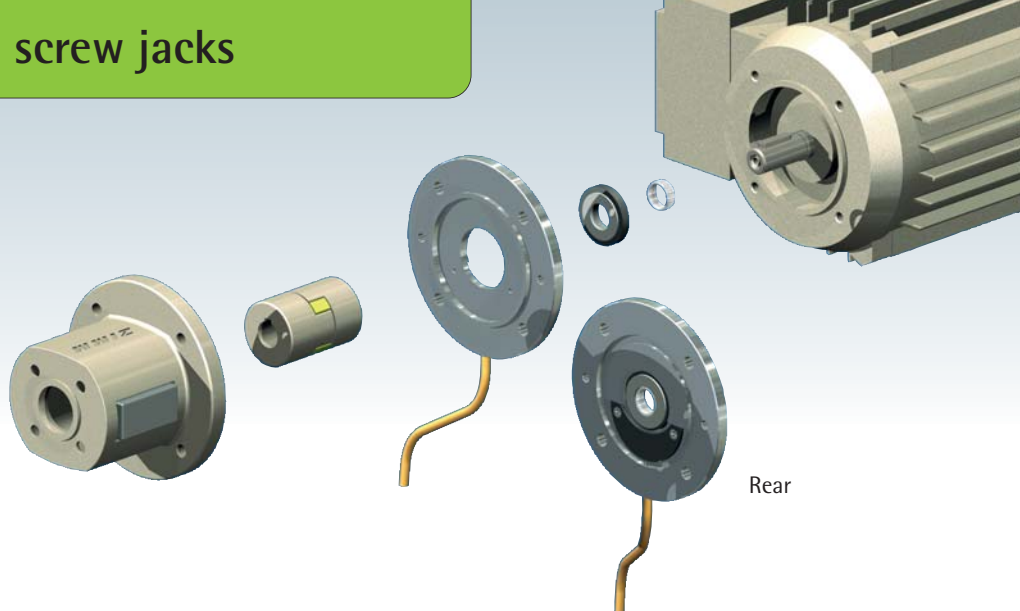

Ordering example:

DIG-160-19-10-HTL

Flange diameter
Shaft diameter
Number of pulses
HTL or TTL

Rotary pulse encoder DIG

We have developed an intelligent intermediate flange which greatly simplifies recording speed and direction of rotation as well as connecting to supervisory control system. Previously this required complex assembly and additions to the drive system; the intelligent flange achieves this economically and is very easy to fit, even when retrofitting drives.

This magnetic pulse encoder is fitted as an intermediate flange between motor and motor flange. This considerably simplifies the integration of incremental encoders in drive systems, whether for purposes of speed matching, of positioning control (e.g. for dosage control) or for synchronisation. We supply a 2 m cable as standard.

Advantages

- Compact design (7 to 12 mm thick)
- Simple and quick assembly
- Protected between motor and motor flange
- Protection class IP 20, with appropriate seal IP67
- Universal HTL signal for all conventional evaluations (PNP, NPN, PNP-NPN, RS 422) or TTL
- Short-circuit proof, protected against polarity reversal and protected against overvoltage transmitter electronics in SMT technology; fully integrated into the flange

Motor flange Part no.	Motor	Rotary pulse encoder DIG-Øa-Ød	c	Screw motor side DIN 912	coupling	Available numbers of pulses						Weight kg	
						1	5	10	20	25	50		100 ²⁾
GSZ-2-MF-80-41	56-B14C	DIG-080-09	10	M5x30	KUZ-09-9/9	X	X			X			0.25
GSZ-2-MF-80-41+P-120-10	63-B14B	DIG-120-11	7	M6x30	KUZ-14-9/11	X	X	X	X				0.27
GSZ-2-MF-80-41+P-105-15	71-B14C	DIG-105-14	7	M6x25	KUZ-14-9/14	X	X	X	X				0.25
Z-5-MF-120-60	63-B14B	DIG-120-11	7	M6x30	KUZ-19-11/11	X	X	X	X				0.27
Z-5-MF-105-68	71-B14C	DIG-105-14	7	M6x30	KUZ-19-11/14	X	X	X	X				0.25
Z-10-MF-120-66	63-B14B	DIG-120-11	7	M6x30	KUZ-19-14/11	X	X	X	X				0.27
Z-10-MF-160-75	71-B5	DIG-160-14	7	M8x45	KUZ-24-14/14	X	X	X	X	X	X	X	0.43
Z-10-MF-160-90	80-B14B	DIG-160-19	7	M8x35	KUZ-24-14/19	X	X	X	X	X	X	X	0.43
Z-25-MF-160-105	71-B5	DIG-160-14	7	M8x45	KUZ-28-16/14	X	X	X	X	X	X	X	0.43
Z-25-MF-160-105	80-B14B	DIG-160-19	7	M8x35	KUZ-28-16/19	X	X	X	X	X	X	X	0.43
Z-25-MF-160-105	90-B14B	DIG-160-24	10	M8x40	KUZ-28-16/24	X	X			X	X	X	0.43
Z-25-MF-160-122	100-B14C	DIG-160-28	10	M8x40	KUZ-28-16/28	X	X			X	X	X	0.43
Z-35-MF-160-111	80-B14B	DIG-160-19	7	M8x35	KUZ-24-19L/19	X	X	X	X	X	X	X	0.43
Z-35-MF-160-111	90-B14B	DIG-160-24	10	M8x35	KUZ-24-19L/24	X	X			X	X	X	0.43
Z-35-MF-B + P-200	100-B14B	DIG-200-28	10	M10x40	KUZ-28-19/28	X	X			X	X	X	0.93
Z-35-MF-B + P-200	112-B14B	DIG-200-28	10	M10x40	KUZ-28-19/28	X	X			X	X	X	0.93
Z-50-MF-200-116	90-B5	DIG-200-24	10	M10x55	KUZ-28-20/24	X	X			X	X	X	0.93
Z-50-MF-200-126	100-B14B	DIG-200-28	10	M10x45	KUZ-28-20/28	X	X			X	X	X	0.93
Z-50-MF-200-126	112-B14B	DIG-200-28	10	M10x45	KUZ-28-20/28	X	X			X	X	X	0.93
Z-100/150-MF-200-138	100-B14B	DIG-200-28	10	M10x50	KUZ-28-25/28	X	X			X	X	X	0.93
Z-100/150-MF-200-138	112-B14B	DIG-200-28	10	M10x50	KUZ-28-25/28	X	X			X	X	X	0.93
Z-100/150-MF-B + P-200	132-B14C	DIG-200-38	12	M10x80	KUZ-38-25/38	X	X			X	X	X	0.93
Z-250-MF-200-168	100-B14B	DIG-200-28	10	M10x50	KUZ-38-28L/28L	X	X			X	X	X	0.93
Z-250-MF-200-168	112-B14B	DIG-200-28	10	M10x50	KUZ-38-28L/28L	X	X			X	X	X	0.93
Z-250-MF-200-168	132-B14C	DIG-200-38	12	M10x50	KUZ-38-28L/38	X	X			X	X	X	0.93

NOTE: the fitted key on the motor shaft may have to be shortened.

²⁾Additional charge



DIG rotary pulse encoder

Mechanical values

Max. speed	6,000 rpm
Temperature range: Electronics	-40 °C to 100 °C at $I_{Load} \leq 20$ mA (120 °C at $I_{Load} \leq 15$ mA)
Cable	-40°C to + 80°C
Flange material / hub material	Aluminium / steel
Connecting cable	PUR sheath / 4 x 0.25 / Ø 5 mm (TTL 6 x 0.14)
Cable length	Standard 2 m or as requested
Version with plug	4-pin plug / cable length 5 m or 10 m (not for TTL version)
Protection class	dependent on the seal between motor and motor flange (max. IP 67 e.g. when sealed with silicone)
Permissible vibration	100 m/s ²
Permissible shock	1000 m/s ²

Electrical values

	HTL (Standard)	TTL version
Supply voltage	10 to 24 VDC / + 20%	5 VDC / ± 5%
Max. output frequency	20 kHz	20 kHz
Output signals	Square wave pulses (2-channel) A + B	Square wave pulses (2-channel) A + B and A + B inv.
Pulse sequence	A 90° B tolerance ± 40° el	A 90° B Tolerance ± 40° el A 90° B inv. Tolerance ± 40° el 180°:180° Tolerance ± 20° el
Pulse/break ratio	180° : 180° tolerance ± 20° el	180°:180° Tolerance ± 20° el
Signal level	$U_{high} \geq U_B - 4$ V at $I_{Load} \leq 10$ mA $U_{low} \leq 1$ V	$U_{high} \geq 3.5$ V $U_{low} \leq 0.3$ V
Max. load current	≤ 30 mA at $U_B = 10$ V and ≤ 20 mA at $U_B = 24$ V	max. 30 mA
Insulation resistance	100 MΩ	100 MΩ
Insulation test	4 kV	4 kV
Short circuit-proof	yes	no
Protected against polarity reversal	yes	no

When evaluating the signals A + B and A + B inv. and $U_B = 10 - 24$ VDC
Please specify when ordering.

Tests

EMC test to EN 50081-1 (emission) and EN 50082-2 (immunity)

Connection arrangement

Connection	U_b	0 V	A	B	A' (TTL)	B' (TTL)
Cable / 4-core (TTL 6-core)	brown	white	yellow	green	pink	grey
Plug / 4-pin	brown	blue	white	black	-	-

Spring pressure brake FDB

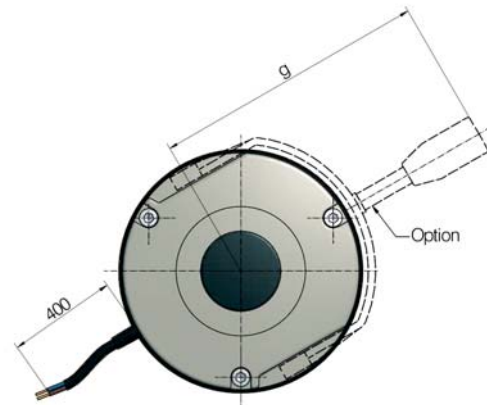
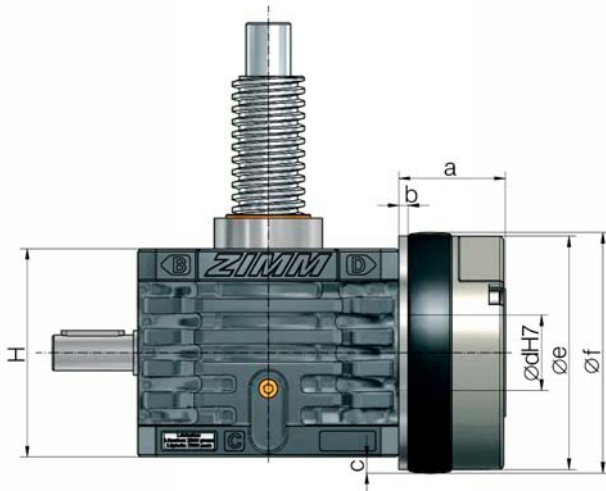
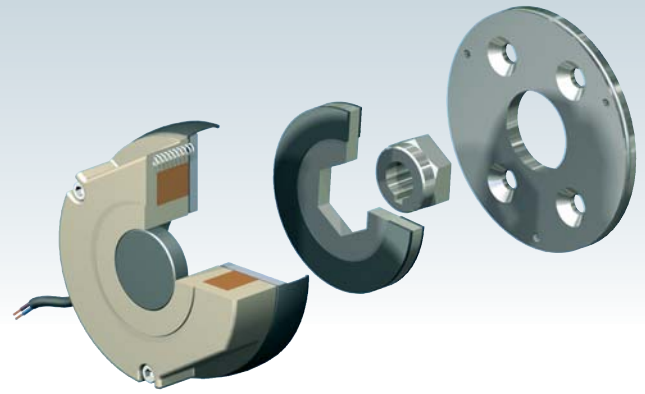

Screw jack size Z/GSZ	Brakes		Braking torque M _B [Nm]	P [W]	H [mm]	Hub Ø [mm]	Dimensions							Weight [kg]
	new ZIMM Designation	old ZIMM Designation					a [mm]	b [mm]	c [mm]	d [mm]	e [mm]	f [mm]	g [mm]	
Z-5	FDB 08	FDB 05	5	22	62	11	46	6	13.5	26	85	89	100	1
Z-10	FDB 08	FDB 05	5	22	74	14	46	6	7.5	26	85	89	100	1
	FDB 10	FDB 10	10	28	74	14	54	7	17.5	32	105	109	110	2
Z-25	FDB 10	FDB 10	10	28	82	16	54	7	13.5	32	105	109	110	2
	FDB 13	FDB 20	20	34	82	16	62	9	26.5	42	130	135	130	3
Z-35	FDB 13	FDB 20	20	34	100	19	62	9	17.5	42	130	135	130	3
	FDB 15	FDB 40	40	42	100	19	69	9	27.5	52	150	155	140	5
Z-50	FDB 13	FDB 20	20	34	116	20	62	9	9.5	42	130	135	130	3
	FDB 15	FDB 40	40	42	116	20	69	9	19.5	52	150	155	140	5
Z-100	FDB 15	FDB 40	40	42	160	25	69	9	-	52	150	155	140	5
	FDB 17	FDB 60	60	50	160	25	81	11	7.5	62	170	175	165	7
Z-150	FDB 15	FDB 40	40	42	185	25	69	9	-	52	150	155	140	5
	FDB 17	FDB 60	60	50	185	25	81	11	-	62	170	175	165	7
	FDB 20	FDB 80	100	64	185	25	91	11	8.0	72	195	201	186	10
Z-250	FDB 17	FDB 60	60	50	204	28	81	11	-	62	170	175	165	7
	FDB 23	FDB 150	150	76	204	28	101	11	13.5	80	225	231	196	15
Z-350	FDB 20	FDB 80	100	64	230	38	91	11	-	72	195	201	186	10
	FDB 26	new!	250	100	230	38	113	11	17.0	-	258	264	285	22

i Other brakes up to Z-1000 available on request.

$$\text{For DC: } P = U \cdot I \rightarrow I = \frac{P}{U}$$

e.g.: FDB 17 at 205 V DC coil voltage

$$I = \frac{50W}{205V} = 0.24 \text{ A}$$

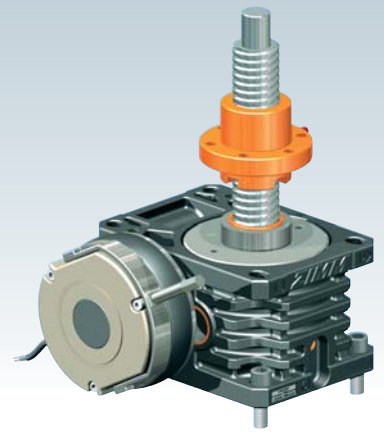

Spring pressure brake FDB

Function

A spring pressure brake is used:

- when there is a lack of self-locking characteristics (high-pitch, double-pitch screws, ball screws KGT)
- where self-locking characteristics are doubtful (as a safety precaution)
- for increased accuracy of stopping position, independent of the lubrication situation

General

The braking torque is generated by compression springs when the brake is deenergised. The brake is released electromagnetically by the application of DC voltage. The protective rings shield the friction faces from external influences. The standard version has protection class IP 54.

Mode of operation

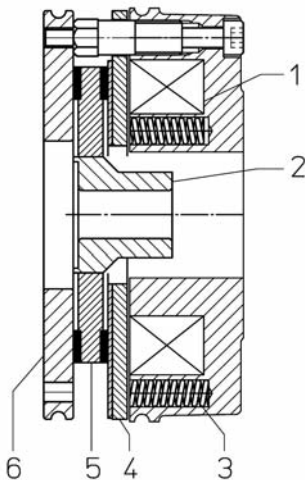

The compression springs (3) exert force on the armature disc (4) which is free to move axially and which presses the brake rotor (5) against the flange (6). The brake rotor in turn is tightly mounted on the hub (2).

The shaft is then braked. Application of DC voltage to the field windings (1) in the magnetic body generates a magnetic force which pulls the armature disc towards the magnetic body. The brake rotor is freed and the brake is released.

In the event of an emergency stop or a power failure, the spring pressure brake ensures that the load is safely braked to a stop.

Electrical supply

The spring pressure brake requires a DC supply. Half-wave and bridge rectifiers are available to provide the power supply to the brakes from the AC mains supply.

Because of the inductance of the solenoid coil, the release of the armature disc on loss of power is not immediate. When the switching off takes place in the AC line from the rectifier, this delay is relatively long.

The delay in switching off can be reduced if the connections available between the rectifier are used to switch the DC line (6 times faster).

If the switching is performed on the AC side, a bridge should be made to the switch contacts.

Manual release

If a manual release lever is fitted, the brake can be released mechanically, e.g. in the event of a power failure.

Brake voltage

The brake voltage is derived from the mains phase voltage. For braked motors, the brake voltage is generally derived from the motor voltage in delta arrangement. The operating voltage of the brake is indicated on the solenoid casing.

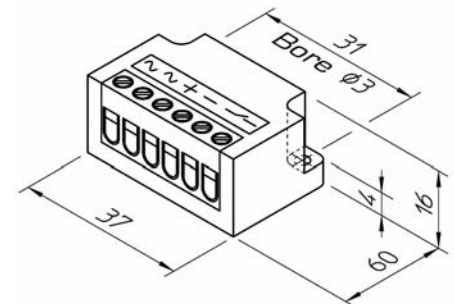

Supply voltage	Brake operating voltage	Rectifier
24V DC	24V DC	-
230V AC	205V DC	GLB Bridge rectifier (PMB 400-S)
230V AC 400V AC 500V AC	105V DC 180V DC 220V DC	GLE Half-wave rectifier (KSE 500/1-S)

 All parts are corrosion-resistant!

Ordering example:

Gearbox size
Brake size
Brake operating DC voltage
Rectifier type (if required)
Manual release HL (if required)

Z-25-FDB 10-205V DC-GLB-HL



Lubrication - screw



Lubricants

Always use the correct lubricants for a long service life!

These lubricants have been carefully selected to suit the screw jack requirements.

Caution should be exercised in using other greases! A "good" grease may not always be the "right" grease.

Trapezoidal screw

Inspect the trapezoidal screw regularly and regrease it depending on the operating cycle. Use the grease that we recommend. These greases are ideally matched to the operating requirements of our screw jack systems.



Standard grease:

Castrol Tribol 4020/460-2 (up to size 150)
Castrol Tribol 3020/1000-2 (from size 250)

As well as the standard greases we also offer greases for special applications:

- High temperature/high duty cycle
- Low temperature
- Heavy duty
- Food industry
- Clean room
- Vacuum, etc.

Most greases are available ex stock. The exact application and the load cycles are important when making the selection. The best strategy is to send us the completed enquiry checklist (Section 7).

The important question is whether it matches the respective requirements.

Ball screw KGT

Lubricate the ball screw KGT every 300 hours of effective operation. For heavy-duty systems every 100 hours.



Grease quantity:

Guidance value approx. 1 ml per cm screw diameter.

Standard grease:

Castrol Tribol 4747/220-2



Ordering example:

Castrol Tribol 4020/460-2,
Cartridge 400g

Automatic lubricator Z-LUB

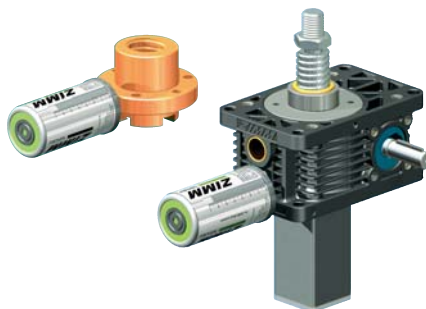
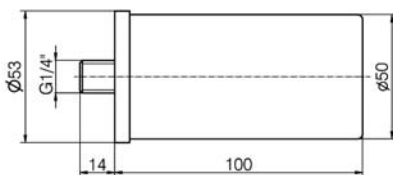

The ZIMM lubricator Z-LUB continuously supplies the screw with lubricant.

The Z-LUB is activated when the run-time is set (1 to 12 months at 20°C) (gas generation cell).

The filling level can be viewed all the time in the transparent housing.

Metering time:	1 to 12 months, infinitely adjustable
Volume:	125 ml
Operating temperature:	+5°C to +55°C (standard grease, mineral-based) for synthetic greases down to -20°C
Thread:	G1/4"
Greases:	ZIMM screw greases



Ordering example:

Z-LUB, ZIMM lubricator
Filling: Castrol Tribol 4020/460-2



Ordering example:

Reducer to G 1/8":
Part no. MSZ-SG-RS1



Infinitely adjustable from 1 to 12 months metering time



KSZ and KGZ – Advantages

Same mounting height – no support plates required

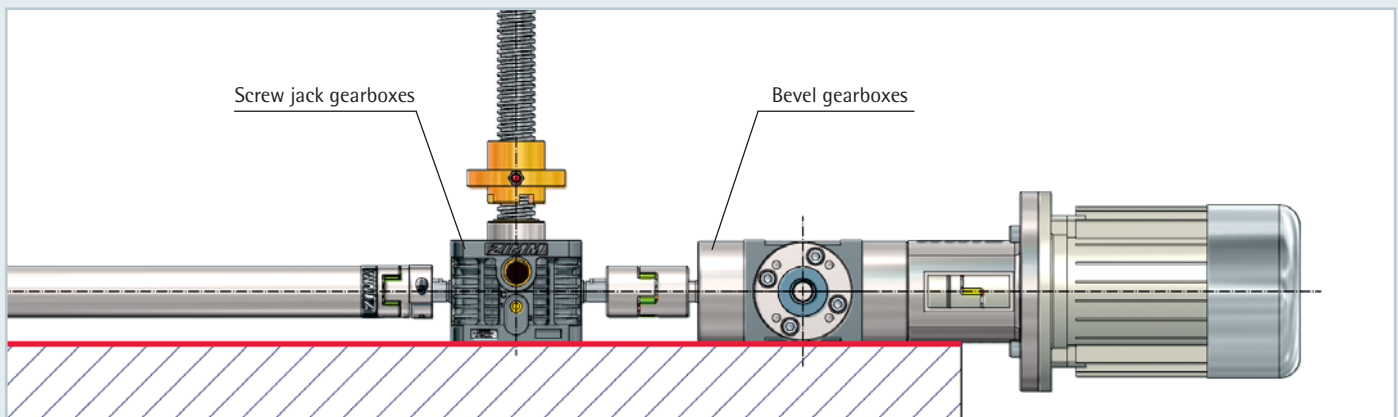

ZIMM bevel gearboxes KSZ and KGZ have the same installation height as the ZIMM screw jack gearbox.

No support plates are required.

Suitable for standard – motor flanges

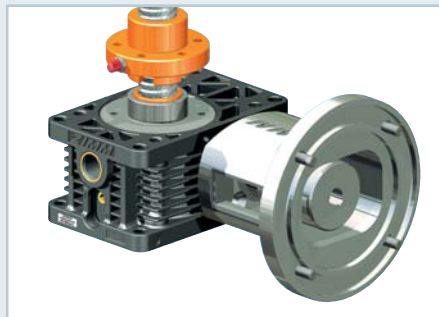
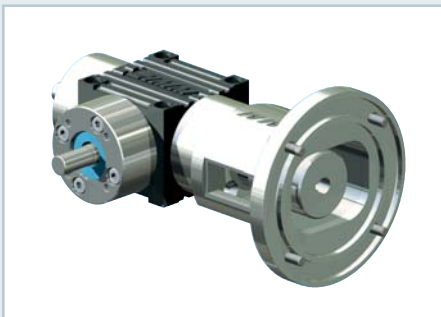

Bevel gearboxes and screw jack gearboxes have the same motor flange fixing pattern.

See Section 4 for standard flanges.

Bevel gearboxes

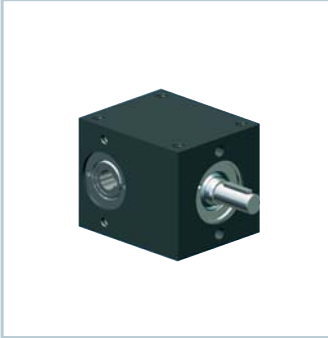

KSZ-2
spiral-toothed

Page 124



KGZ
straight-toothed

Page 126



KSZ
spiral-toothed

Page 127

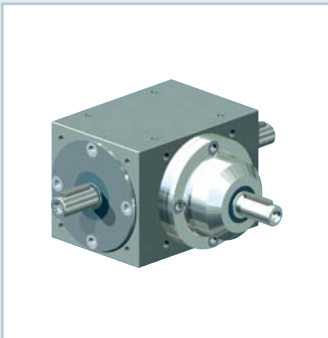

KST
High-performance gearbox
spiral-toothed

Page 128

KSZ-2 layout examples



The KSZ-2 is a bolt-on gearbox and therefore where larger screw jacks are used the layouts will be different.

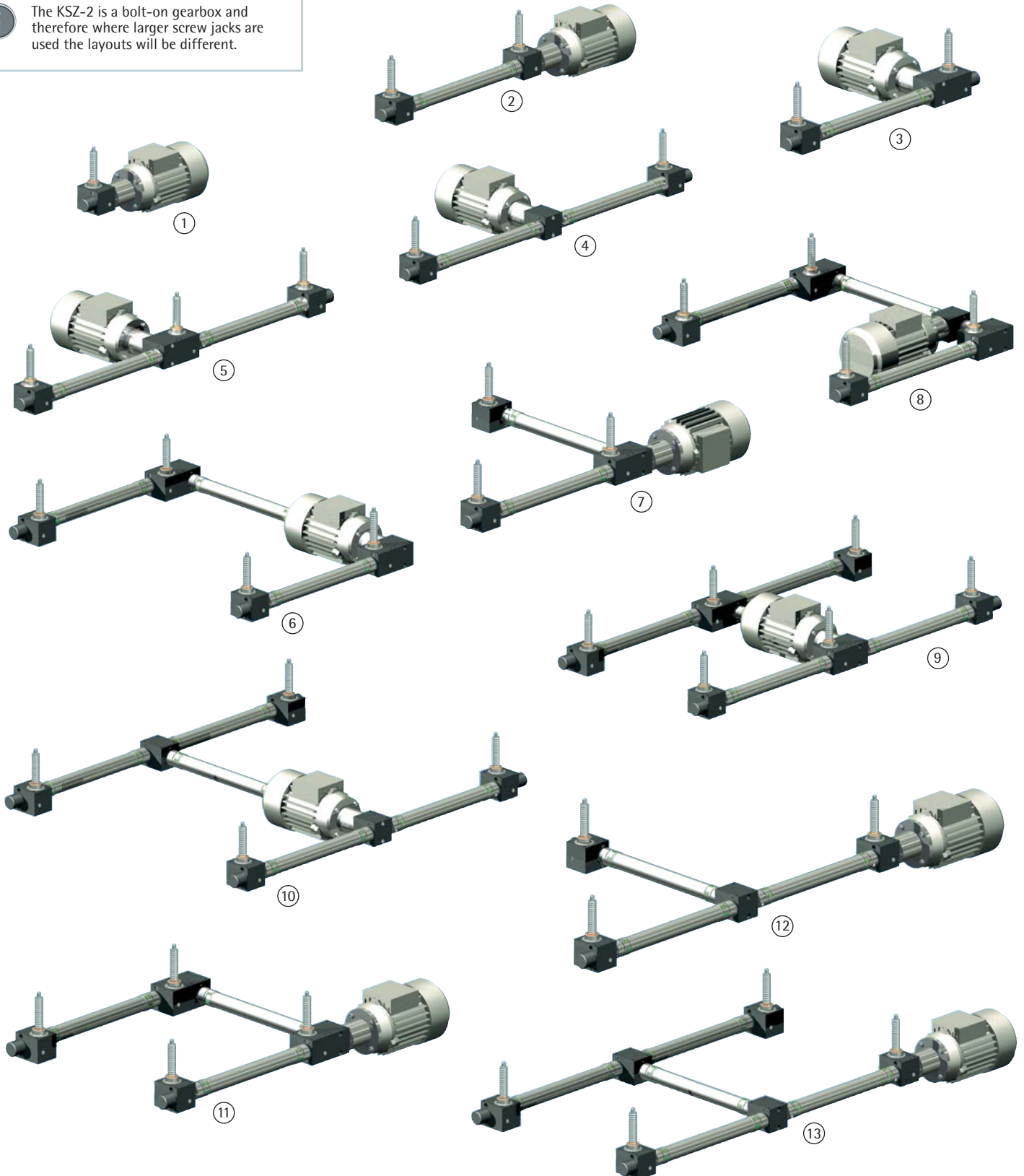

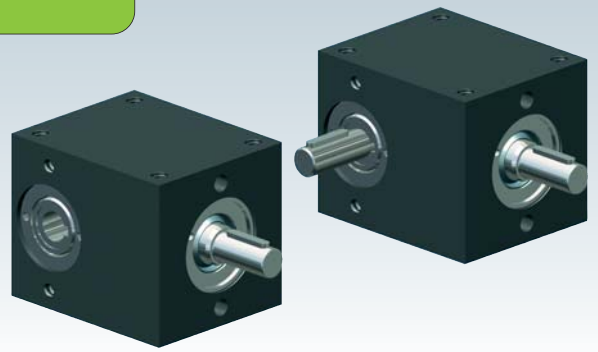

KSZ-2 bevel gearbox

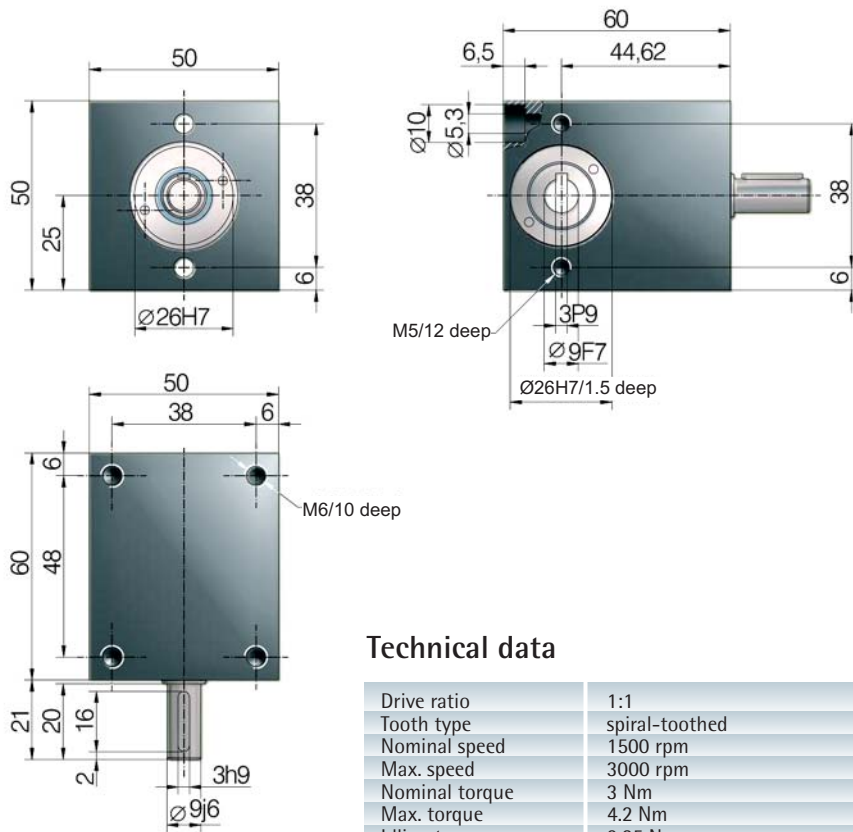

Technical data

Drive ratio	1:1
Tooth type	spiral-toothed
Nominal speed	1500 rpm
Max. speed	3000 rpm
Nominal torque	3 Nm
Max. torque	4.2 Nm
Idling torque	0.25 Nm
Duty factor	up to 40%
Lubricant	fluid grease
Weight	0.45 kg
Housing material	hard anodised aluminium
Shaft material	stainless steel



Part no.: KSZ-2

Spiral-toothed

Spiral toothing ensures high torque and low running noise

Bolt-on, shaft-mounted gearbox

The KSZ-2 has a continuous hollow shaft. Thus it can easily be bolted on to the Z-2 screw jack gearbox and requires very little space.

Easy bolt-on assembly:

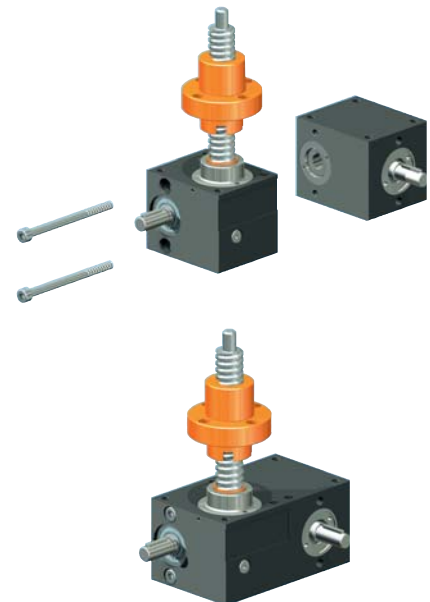

Part no.: 2 bolts DIN 912 M5x55, A4

Stub shaft

Fitting a stub shaft allows the KSZ-2 to be used as a conventional right-angle gearbox.

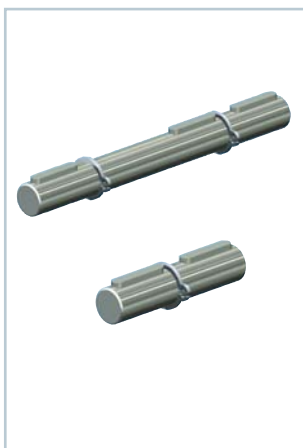

Stub shaft T (long)

Material:
stainless steel

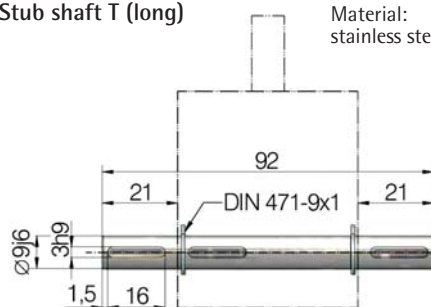

Part no.: KSZ-2-STW-T

Stub shaft L (short)

Material:
stainless steel

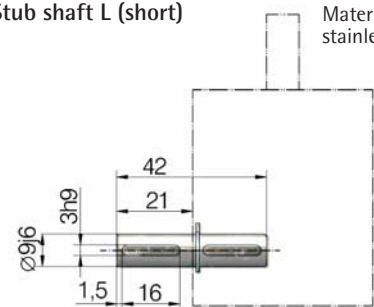

Part no.: KSZ-2-STW-L

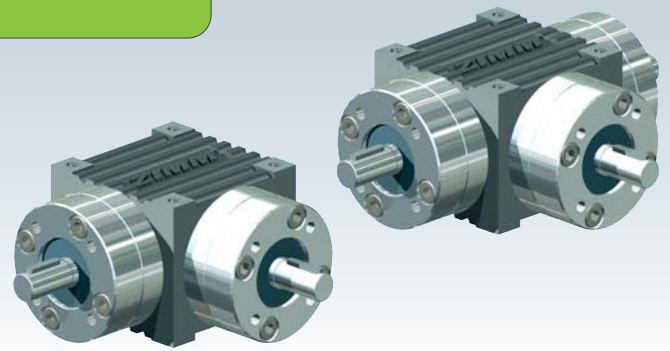

KGZ straight-toothed

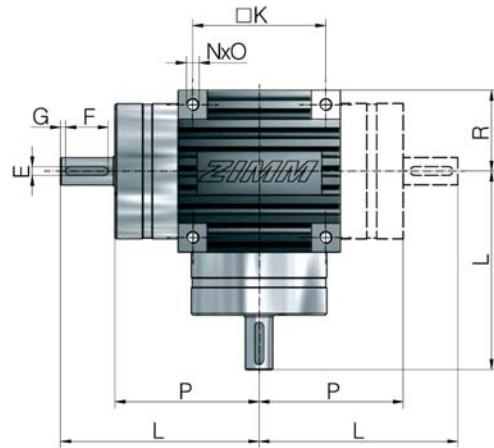
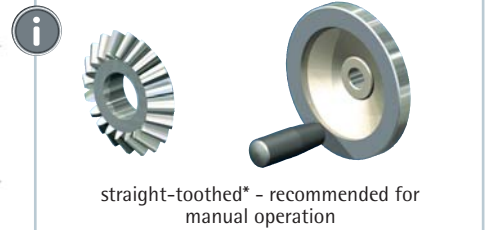
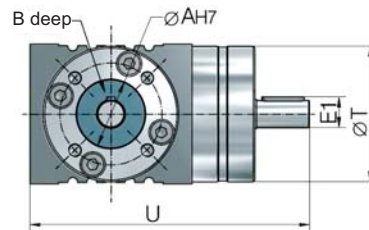
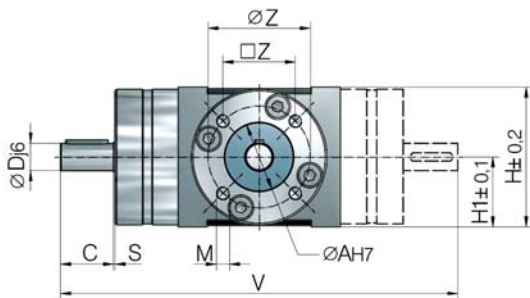

Shaft configuration

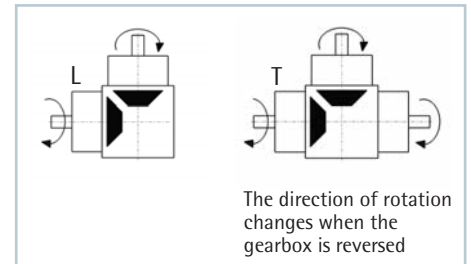

If one of the shafts is vertical, this must be stated when ordering: e.g.: "vertical drive shaft"

Dimensions

Part no.	Ø AH7	B	C	Dj6	En9	E1	F	G	H	H1	□K	L	L1	M	N	O	P	R	S	Ø T	U	V	Ø Z	□ Z
KGZ-5-L/T-1	32	2	21	11	4	11.5	16	3	62	31	60	90	30	M6	M6	13	69	36.0	1.0	61.5	126.0	180	46.1	32.5
KGZ-25-L/T-1	40	3	31	16	5	18.0	25	3	82	41	78	117	39	M8	M8	15	86	47.5	1.5	80.0	164.5	234	60.0	42.0

Technical data

Size	Permissible torque [Nm] at 10 to 1500 rpm		Moment of inertia Torque [kg cm ²]		Permissible radial load F_R [N] at the shaft end at n_1 [rpm]				Weight [kg]	
	L version	T version	L	T	500	750	1000	1500	L	T
KGZ-5	6.5	7.5	0.429	0.565	250	210	180	150	2.7	3.4
KGZ-25	14.0	16.0	1.283	1.569	600	500	450	360	5.7	7.0

Material specifications

- Housing material: GGL 20
- Bevel gears: straight-toothed, gas nitrided
- Roller bearings
- Permanent lubrication with synthetic oil
- Temperature range -10°C to +90°C

- Drive ratio $i = 1:1$
- Maximum speed 1500 rpm
- Duty factor 20% (max.)
- Repair: change complete gearbox
- In the upper speed range, values of 90 to 100 dBA may occur



Ordering example:

KGZ-25-T-1

Bevel gearbox
straight-toothed
Size
Shaft configuration T-1 or L-1

* KGZ-1 straight-toothed gearboxes are especially suitable for manual operation or infrequent motorised operation. Running noise is higher in comparison with KSZ spiral-toothed bevel gearboxes. KGZ-1 has the same dimensions as KSZ.

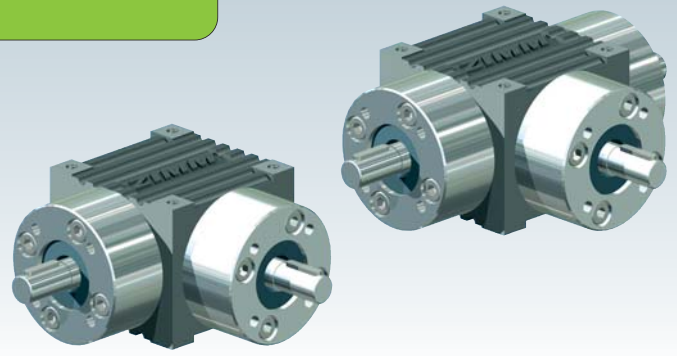

KSZ spiral-toothed

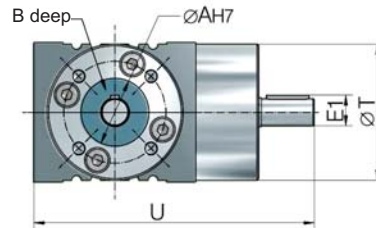
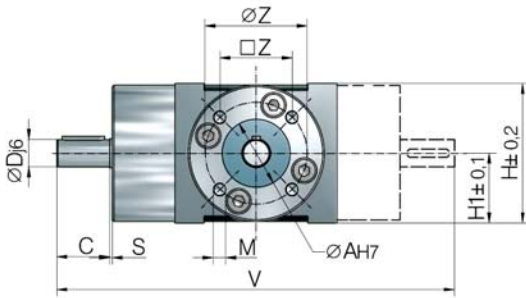

The spiral-toothed version is recommended for motorised operation

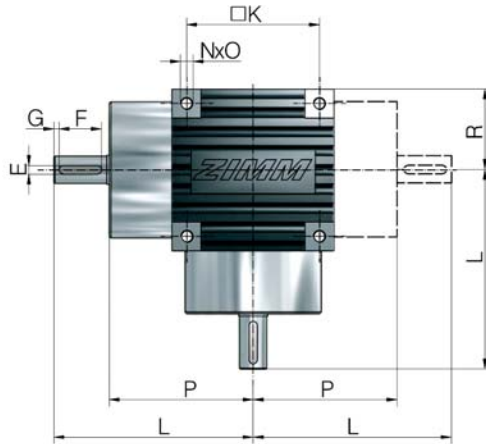

Shaft configuration

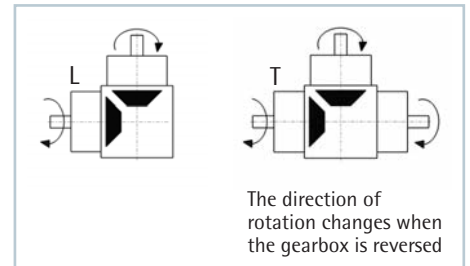

The direction of rotation changes when the gearbox is reversed

If one of the shafts is vertical, this must be stated when ordering: e.g.: "vertical drive shaft"

Dimensions

Part no.	$\varnothing A_{H7}$	B	C	D_{j6}	E_{H9}	E_1	F	G	H	H_1	$\square K$	L	L_1	M	N	O	P	R	S	$\varnothing T$	U	V	$\varnothing Z$	$\square Z$
KSZ-5-L/T	32	2	21	11	4	12.5	16	3	62	31	60	90	30	M6	M6	13	69	36.0	1.0	61.5	126.0	180	46.1	32.6
KSZ-10-L/T	35	3	26	14	5	16.0	16	5	74	37	70	105	35	M8	M8	15	79	42.5	1.5	73.5	147.5	210	49.5	35.0
KSZ-25-L/T	40	3	31	16	5	18.0	25	3	82	41	78	117	39	M8	M8	15	86	47.5	1.5	80.0	164.5	234	60.0	42.4
KSZ-50-L/T	52	4	39	20	6	22.5	25	5	116	58	110	165	55	M10	M10	15	126	67.5	2.0	115.0	232.5	330	86.0	50x70

Technical data

Bevel gearbox	Permissible torque [Nm] at various speeds [rpm]						Moment of inertia [kg cm ²]		F_{radial} [N]	Weight [kg]
	0	10	100	750	1500	3000	L	T		
KSZ-5-L/T	29.5	13.9	13.9	13.8	13.5	13.3	0.429	0.565	140	L 2.7 T 3.4
KSZ-10-L/T	58.4	25.4	25.2	25.1	23.1	19.1	1.129	1.436	200	L 4.5 T 5.6
KSZ-25-L/T	82.4	32.9	32.9	32.7	30.1	24.1	1.283	1.569	300	L 5.7 T 7.0
KSZ-50-L/T	343.0	143.3	143.1	119.3	95.8	75.3	10.008	12.596	1100	L 19.6 T 21.8

Manufacturing and quality features:

- Housing material: GGL 20
- Low-backlash version
- Quiet running
- High torque transmission in a small size
- Spiral-toothed bevel gears:
- Pre-loaded taper roller bearings
- Drive ratio $i = 1:1$

- Permanent lubrication with synthetic oil; oil change required only on heavy duty applications
- Sealing by means of shaft seals and O-rings
- Max. 40% duty factor at 1500 rpm
- Compatible with screw jack modular components
- All installation dimensions symmetrical
- Shaft ends are identical to those for screw jack gearboxes of the same size



Ordering example:

Bevel gearbox
spiral-toothed
Size
T or L shaft configuration

KSZ-25-T

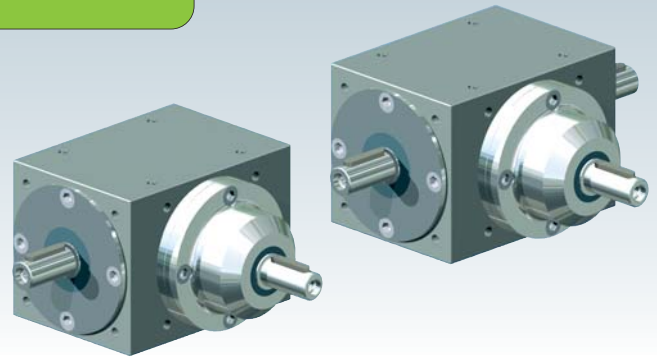

KST high-performance gearbox

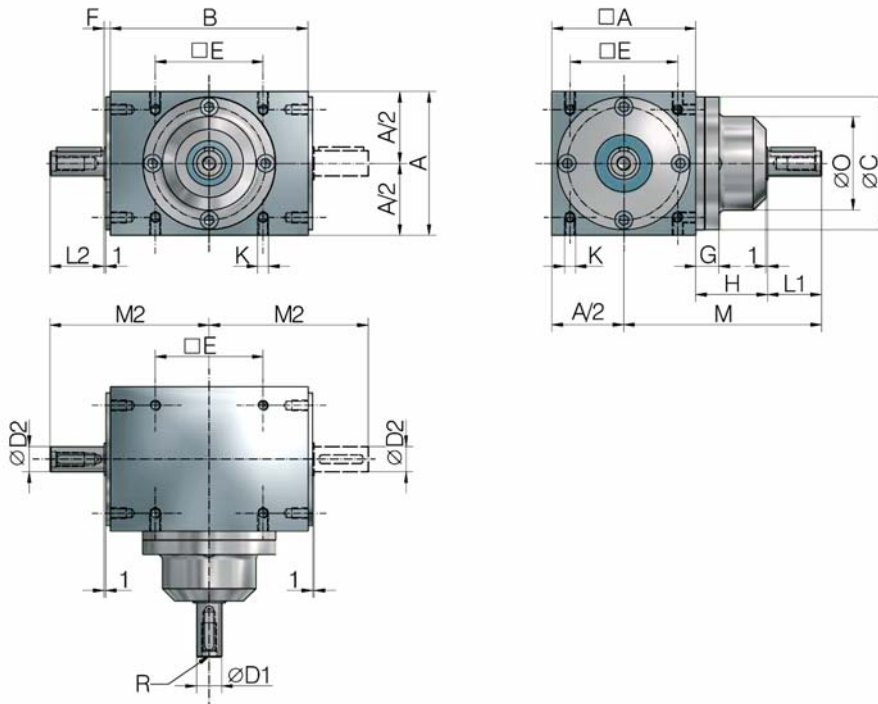

If one of the shafts is vertical, this must be stated when ordering: e.g.: "vertical drive shaft"

CAUTION:

Dimensions are for a 1:1 drive ratio.
Dimensions may differ for other ratios.
Please ask for a dimension data sheet.

Gearbox size	□A	B	C ₁₇	D _{1j6}		□E	M	M ₂	L ₁		F	G	H	K	R	O	DIN 6885 key
				D _{2j6}					L ₂								
KST-00	80	110	74	14	60	110	88.5	30	3.5	13	40	M6	M6	52	5x5		
KST-01	110	145	102	22	82	135	111.0	35	3.5	14	45	M8	M8	70	6x6		
KST-A1	140	175	130	32	105	165	137.0	45	4.5	14	50	M10	M10	90	10x8		
KST-B1	170	215	160	42	130	210	172.0	60	4.5	18	65	M12	M12	110	12x8		
KST-C1	210	260	195	55	160	275	220.0	85	5.0	18	85	M16	M16	135	16x10		
KST-D1	260	330	245	65	200	340	270.0	100	5.0	23	110	M16	M16	150	18x11		
KST-E1	330	430	310	75	260	435	340.0	120	5.0	29	150	M20	M20	230	20x12		

$$K_{\text{deep}} = K \cdot 1.5$$

Quality features

- Extremely quiet operation
- Maintenance-free, with minimum backlash
- High torques in relation to size
- High duty factor or continuous operation
- High concentricity
- Suitable for the most demanding applications

Manufacturing features

- Spiral bevel gears, palloid-toothed, case-hardened, precision lapped as pairs
- Tooth contact mechanically adjusted to +/- 15µ
- Roller bearings tested for noise
- GD250 (Meehanite) cast-iron housing, low-distortion with good torsional stiffness
- Radial shaft seals with dust lip

- Oil filling: synthetic oil HT68, permanent lubrication
- Standard drive ratio $i = 1:1$, other ratios on request
(CAUTION: Dimensions may change)

KST high-performance gearbox

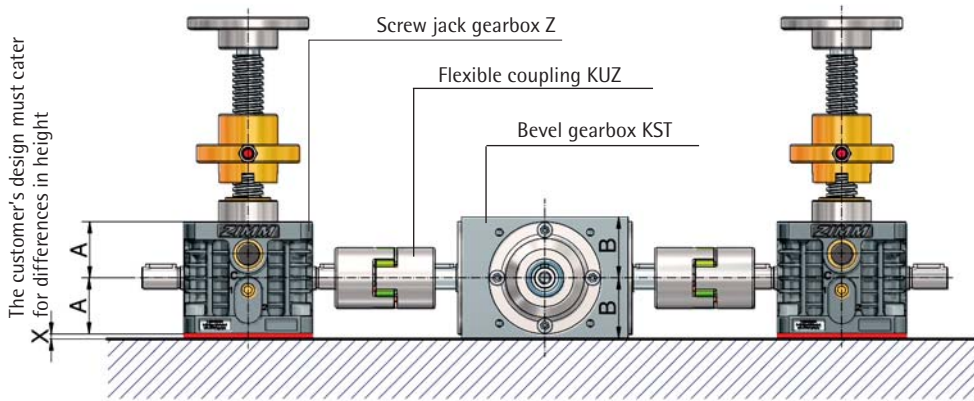

Size	Permissible torque [Nm]			Permissible radial load F_R [N] at the shaft end		Weight [kg]
	max. M_d	1500 rpm	3000 rpm	d_1	d_2	
KST-00	80	28	20	300	300	5
KST-01	200	65	50	1100	1100	11
KST-A1	380	130	95	1500	2700	21
KST-B1	620	230	160	2000	3700	36
KST-C1	1200	390	-	3250	5000	64
KST-D1	2000	740	-	3800	7500	124
KST-E1	3500	1300	-	4500	9200	250

Special instructions:

If the duty factor is more than 20% and the speed is more than 3000 rpm, you should specify a grease and oil level inspection glass when ordering.

The KST bevel gearbox is available on request with drive ratios of 1:2 (higher output speed) to 6:1 (lower output speed) and as a flanged gearbox for direct attachment to your motor or servomotor.

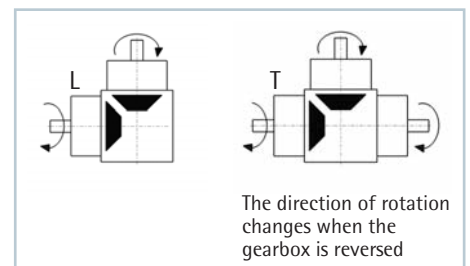
Shaft configuration**Ordering example:**

KST-01-L-1:1

Bevel gearbox
spiral-toothed
Size
T or L shaft configuration
Drive ratio 1:1 (other ratios on request)

everything on the move

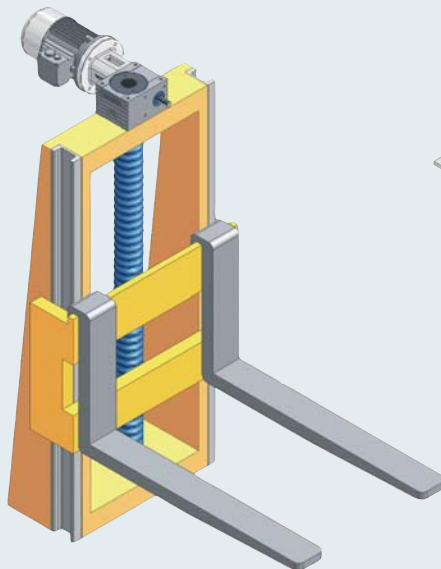
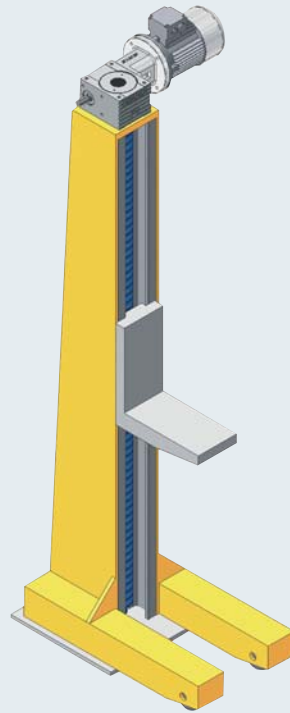
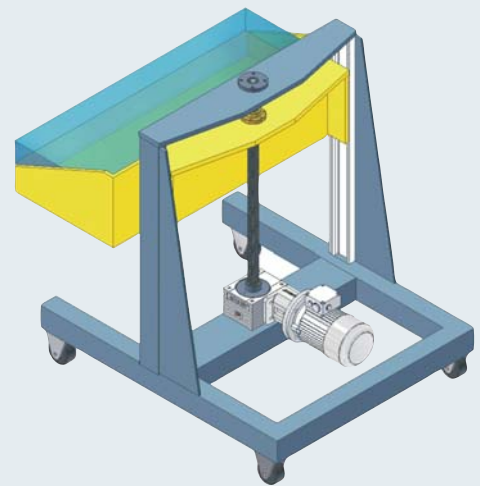
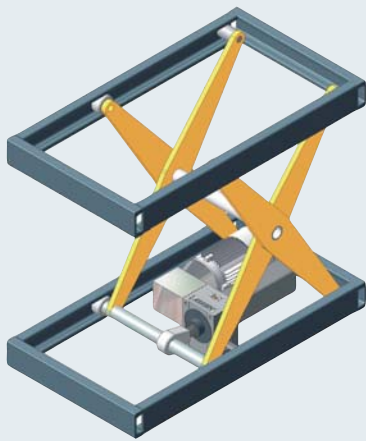

...combinations of
screw jacks and
linear guides

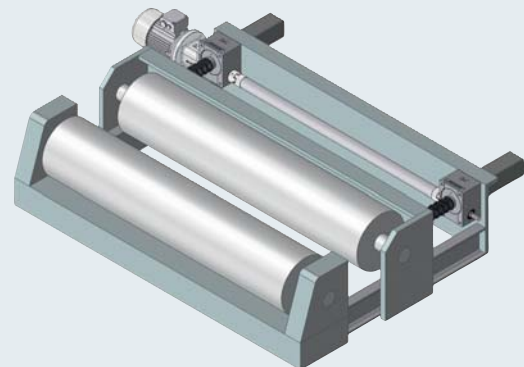

Linear guides

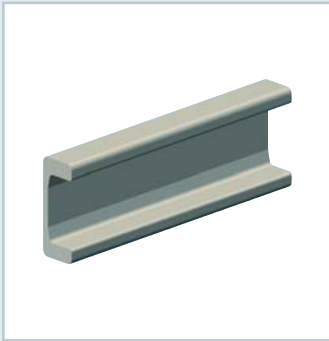

U-profiles

Page 132



Bearings

Page 134

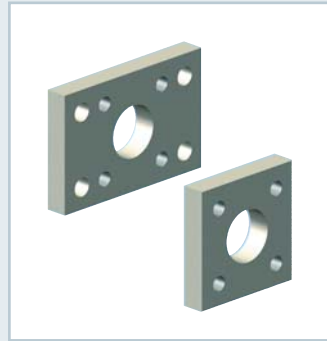

Flange plates

Page 135



Technical data
Technical specifications

Page 136

Overview

Type	Profile Height [in mm]	Bearing, adjustable		Flange plates	
		Standard	Restricted tolerance	Rectangle	Square
ZP-300-K	65	ZR-U2-525-RS*		ZF-00	ZF-00 Q
ZP-300-0	86.5	ZR-U2EX-620-RS	ZR-U2EX-625-RS	ZF-00 / ZF-01	ZF-00 Q / ZF-01-Q
ZP-300-1	103.2	ZR-U2EX-701-RS	ZR-U2EX-704-RS	ZF-02	ZF-02-Q
ZP-300-2	121.3	ZR-U2EX-777-RS	ZR-U2EX-780-RS	ZF-03	ZF-03-Q
ZP-300-3	135.4	ZR-U2EX-884-RS	ZR-U2EX-889-RS	ZF-04	ZF-04-Q
ZP-300-4	157.2	ZR-U2EX-1077-RS		ZF-05 / ZF-06	ZF-05-Q / ZF-06-Q
ZP-300-5	175	ZR-U2EX-1230-RS		ZF-05 / ZF-06	ZF-05-Q / ZF-06-Q
ZP-300-6	201.5	ZR-U2EX-1490-RS		ZF-05 / ZF-06	ZF-05-Q / ZF-06-Q

*the bearing for the profile 300-K is fixed and not adjustable

U-profiles are made of hot-rolled 18MnNb6 in lengths up to approx. 12 m. The advantage compared to material S355J2G (St52-3) is that the elastic limit and tensile strength are considerably higher. Our profiles are generally aligned. We supply all profiles in fixed lengths.

On request we can supply profiles in paint primer finish or hot-dip galvanised. We will be happy to offer fully finished profiles to your requirements, e.g. drilled, milled, with welded-on elements.

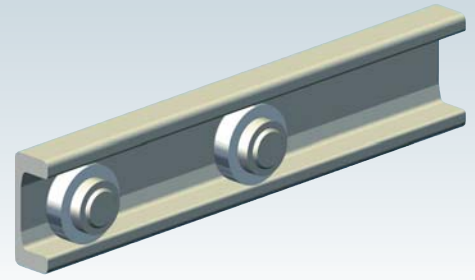

Hot-rolled U-profiles

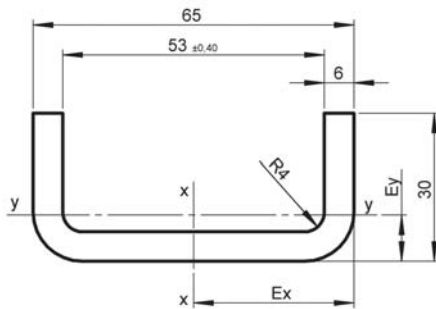

Rolled U-profiles

This U-profile is rolled and pickled in S235JR material, in lengths up to approx. 8 m.

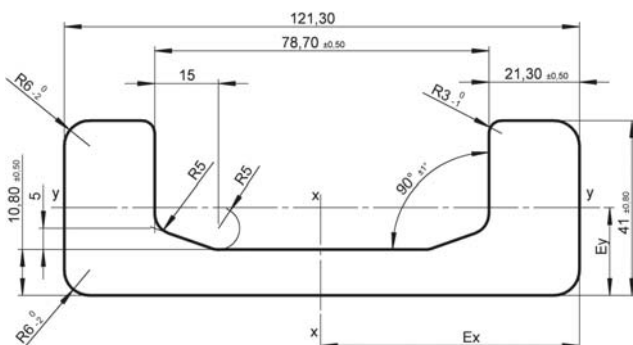
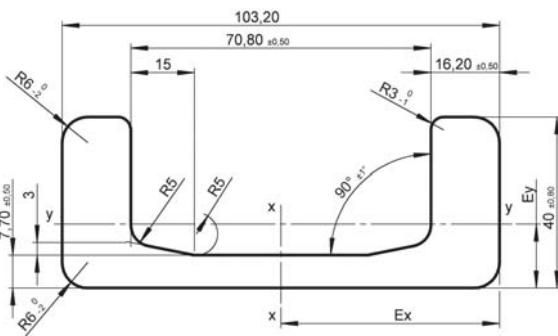
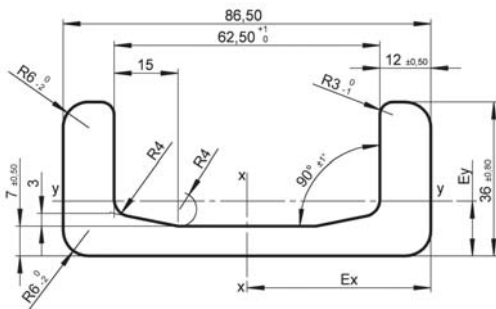

Part no.:	ZP-300-K
Weight:	5.30 kg/m
Wx:	11.90 cm ³
Wy:	2.50 cm ³
Ix:	38.80 cm ⁴
Iy:	5.20 cm ⁴
Ex:	32.50 mm
Ey:	9.40 mm

Part no.:	ZP-300-0
Weight:	10.50 kg/m
Wx:	32.00 cm ³
Wy:	6.00 cm ³
Ix:	137.00 cm ⁴
Iy:	15.00 cm ⁴
Ex:	43.25 mm
Ey:	12.87 mm

Part no.:	ZP-300-1
Weight:	14.78 kg/m
Wx:	53.00 cm ³
Wy:	11.00 cm ³
Ix:	273.00 cm ⁴
Iy:	27.00 cm ⁴
Ex:	51.60 mm
Ey:	14.99 mm

Part no.:	ZP-300-2
Weight:	20.93 kg/m
Wx:	81.00 cm ³
Wy:	15.43 cm ³
Ix:	493.58 cm ⁴
Iy:	37.92 cm ⁴
Ex:	60.65 mm
Ey:	15.43 mm

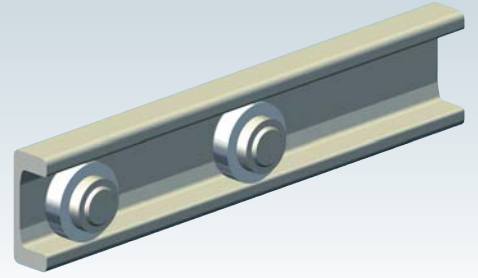

Hot-rolled U-profiles

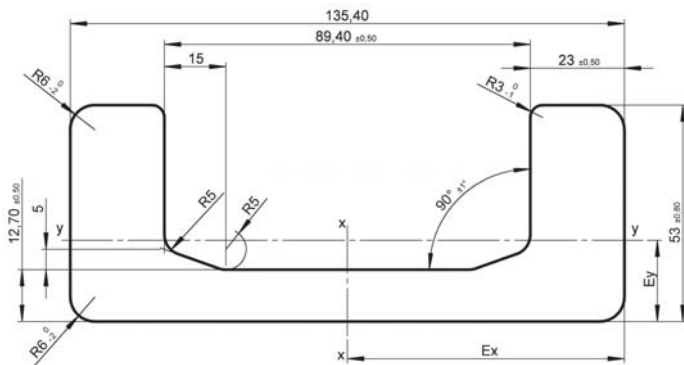

Part no.:	ZP-300-3	
Weight:	28.60 kg/m	
Wx:	127.80 cm ³	
Wy:	27.03 cm ³	
Ix:	865.23 cm ⁴	
Iy:	89.47 cm ⁴	
Ex:	67.70 mm	
Ey:	19.90 mm	

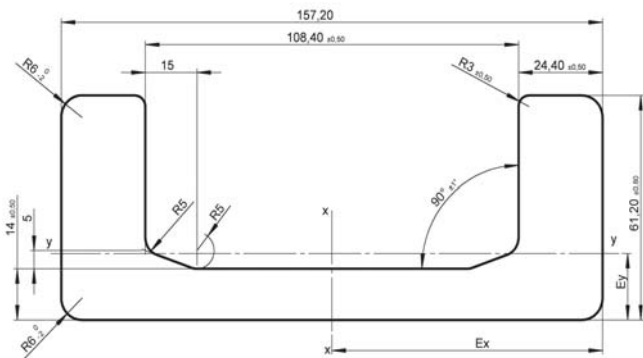

Part no.:	ZP-300-4	
Weight:	35.90 kg/m	
Wx:	190.12 cm ³	
Wy:	39.00 cm ³	
Ix:	1494.32 cm ⁴	
Iy:	150.98 cm ⁴	
Ex:	78.60 mm	
Ey:	22.49 mm	

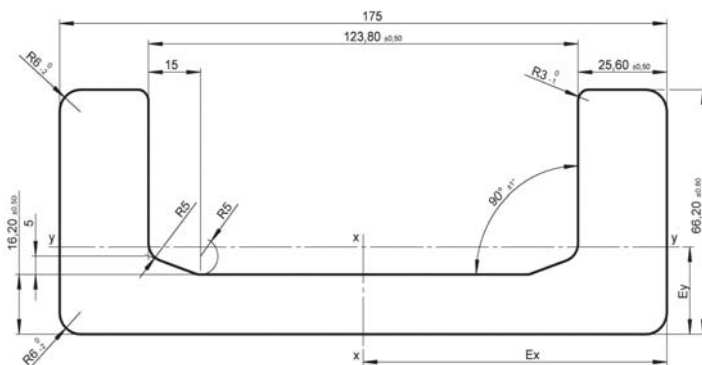

Part no.:	ZP-300-5	
Weight:	42.90 kg/m	
Wx:	249.75 cm ³	
Wy:	48.42 cm ³	
Ix:	2185.32 cm ⁴	
Iy:	205.84 cm ⁴	
Ex:	87.50 mm	
Ey:	19.41 mm	

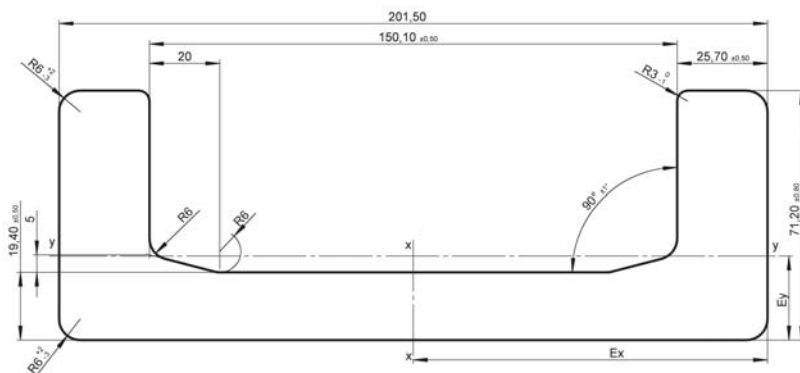

Part no.:	ZP-300-6	
Weight:	52.25 kg/m	
Wx:	339.76 cm ³	
Wy:	57.15 cm ³	
Ix:	3423.08 cm ⁴	
Iy:	269.52 cm ⁴	
Ex:	100.75 mm	
Ey:	20.01 mm	

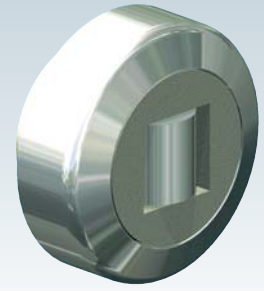

Combined bearing, eccentric adjustment

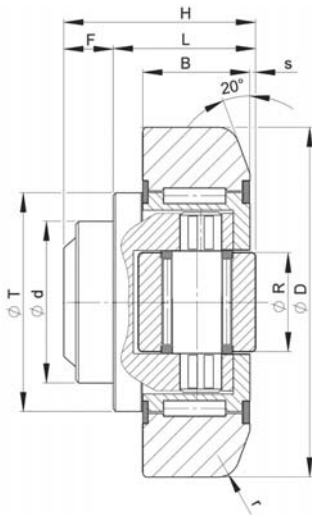

Adjustable eccentric axial bearing

Removing the front cover gives free access to the axial bearing. Turning the axial bearing changes the dimensions H, L and s by between 1.5 mm and 4.0 mm depending on the size of the bearing. See column L. Up to 8 intermediate positions are available.

After the adjustment has been set correctly, the front cover is refitted. Apply thread locking to the screws at reassembly.

i	C	=	dynamic radial
	Co	=	static radial
	CΔ	=	dynamic axial
	CoΔ	=	static axial

Part no.	d +0.0 -0.05 mm	D mm	H mm	B mm	L mm	F mm	T mm	R mm	r mm	s mm	C kN	Co kN	CΔ kN	CoΔ kN	Weight kg	Profile U-type
ZRU2-525*	30	52.5	33.0	17	27.0	6.0	40	15	2.0	5.0	24	33.0	8	8	0.36	ZP-300-K
ZRU2EX-620	30	62.0	37.5-39.0	20	30.5-32.0	7.0	42	20	3.0	4.0-5.5	31	36.0	12	12	0.53	ZP-300-0
ZRU2EX-625	30	62.5	37.5-39.0	20	30.5-32.0	7.0	42	20	3.0	4.0-5.5	31	36.0	12	12	0.55	ZP-300-0
ZRU2EX-701	35	70.1	44.0-45.5	23	36.0-37.5	8.0	48	20	4.0	4.0-5.5	45	50.5	12	12	0.80	ZP-300-1
ZRU2EX-704	35	70.4	44.0-45.5	23	36.0-37.5	8.0	48	20	4.0	4.0-5.5	45	50.5	12	12	0.81	ZP-300-1
ZRU2EX-777	40	77.7	48.0-49.5	23	37.0-38.5	11.0	54	26	4.0	3.5-5.0	48	58.0	18	18	1.0	ZP-300-2
ZRU2EX-780	40	78.0	48.0-49.5	23	37.0-38.5	11.0	54	26	4.0	3.5-5.0	48	58.0	18	18	1.01	ZP-300-2
ZRU2EX-884	45	88.4	57.0-58.5	30	44.0-45.5	13.0	59	26	4.0	4.0-5.5	76	102.0	22	23	1.61	ZP-300-3
ZRU2EX-889	45	88.9	57.0-58.5	30	44.0-45.5	13.0	59	26	4.0	4.0-5.5	76	102.0	22	23	1.62	ZP-300-3
ZRU2EX-1077	60	107.7	69.0-71.0	31	55.0-57.0	14.0	69	30	5.0	4.0-6.0	94	159.0	38	47	2.82	ZP-300-4
ZRU2EX-1230	60	123.0	72.3-76.3	37	56.0-60.0	16.3	80	34	5.0	5.0-9.0	125	222.0	41	67	3.90	ZP-300-5
ZRU2EX-1490	60	149.0	78.5-82.5	45	58.5-62.5	20.0	108	34	3.0	6.0-10.0	167	343.0	68	101	6.50	ZP-300-6

*the bearing for the profile ZP-300-K is fixed and not adjustable. It can be adjusted only by means of shims under the flange plate.

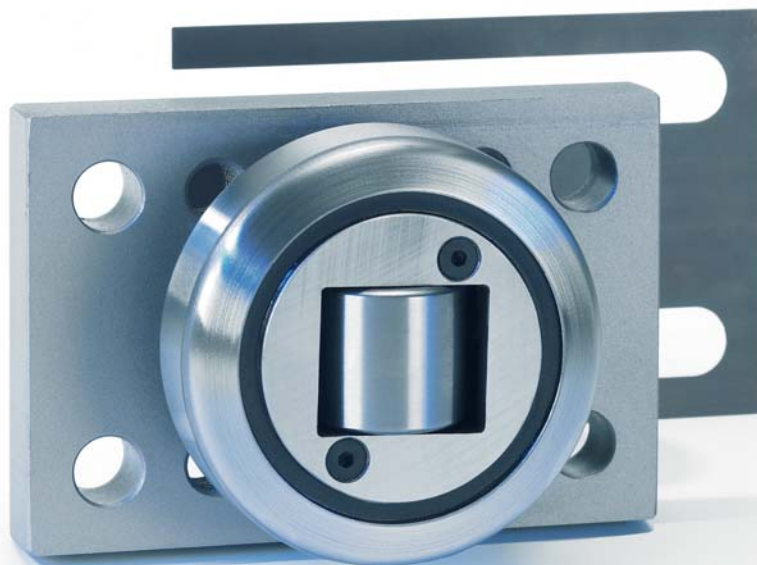

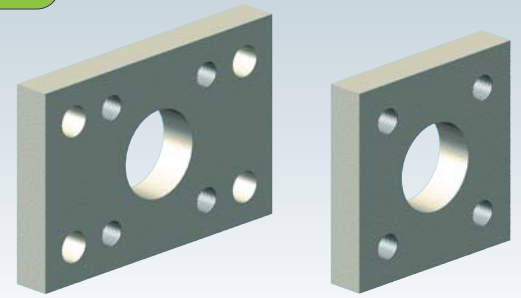

Flange plates for combined bearings

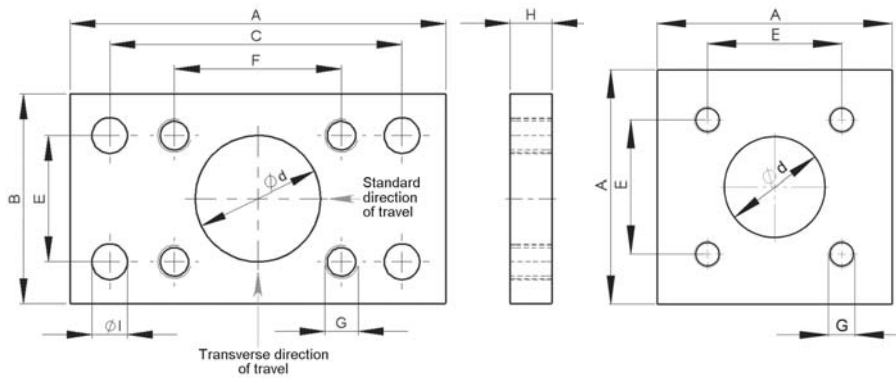

The determining factor for selection of the flange plate is the diameter "d" of the combined bearing.

If the flange and bearing are ordered together they are supplied ready welded to each other.

Rectangular flange, e.g.: ZF-01

Square flange, e.g.: ZF-01-Q

Material: Steel, S235J.K, stainless steel on request

Part no.	d h11 mm	A mm	B mm	C mm	I mm	E mm	F mm	G mm	H mm	Weight kg
ZF-00	30	90	50	70	8.5	30	40	M8	10	0.26
ZF-01	30	100	60	80	10.5	40	40	M10	10	0.36
ZF-02	35	120	80	90	12.5	50	50	M12	15	0.90
ZF-03	40	120	80	90	12.5	50	50	M12	15	0.86
ZF-04	45	160	100	120	17.0	60	60	M16	20	2.35
ZF-05	60	180	120	140	17.0	80	80	M16	20	2.70
ZF-06	60	200	150	160	17.0	100	100	M16	20	4.00
ZF-00-Q	30	50	-	-	-	30	-	M8	10	0.20
ZF-01-Q	30	60	-	-	-	40	-	M10	10	0.30
ZF-02-Q	35	80	-	-	-	50	-	M12	15	0.72
ZF-03-Q	40	80	-	-	-	60	-	M12	15	0.68
ZF-04-Q	45	120	-	-	-	90	-	M16	20	1.89
ZF-05-Q	60	140	-	-	-	80	-	M16	20	2.10
ZF-06-Q	60	160	-	-	-	100	-	M16	20	3.50

Shims for the flange plates

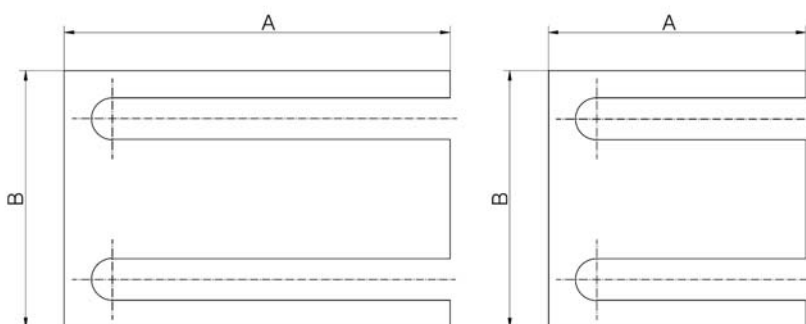

Rectangular ZDB

Square ZDBQ



Ordering example:

ZDB-050-05

ZDB = rectangular
ZDBQ = square
Diameter "d" of the flange plate
Shim thickness
05 = 0.5 mm; 10 = 1.0 mm

Material: Steel DC01 or comparable, stainless steel on request

Technical data



Materials:

Bearings: Inner ring and cylindrical bearing: Steel 100Cr6, hardened and tempered
Outer rings: Case-hardening steel 20MnCr5, case-hardened
Weld-on pin: S355J2G3 or comparable
18MnNb6 (profile ZP-300-K in S235JR)

Profiles: S235J..K

Flange plates: S235J..K

Shims for Flange plates: Steel DC01 or comparable, stainless steel on request

Flange plates:

If the bearing and flange plate are ordered together they are supplied ready welded to each other.

If the customer is performing the welding, please note the following recommendation:
It is not essential that the combined bearings are dismantled by a fitter before being welded in.

Welding recommendation:

- Standard welding wire G4Si1
- Wire diameter 1.2
- with little transfer of heat

If however the bearing is dismantled, when the screws are reinserted they should be locked with "medium strength" thread locking.

Speed:

max. 1.5m/s travel speed



Temperatures

Standard: -30°C to +130°C

Special bearings are available on request for:

- high temperatures up to 250°C
- for operation in cold stores down to -40°C
- for operation in a vacuum (coarse, fine or high vacuum)

Corrosion resistant:

Profiles: rolled profiles can be painted.
On request, profiles can be supplied spray galvanised 80-100µm (galvanised finish can be painted)

Bearings: Customers usually oil the bearings lightly as protection against corrosion.
Bearings with coated backs are available on request

Tolerances:

Size, type and bearing tolerances to DIN 620, tolerance class: PN
Load factors: C = dyn. load factor ISO 281/1, Co = stat. load factor ISO 76

Setting the bearings (axial):

The setting of the axial play can be performed either by adjusting the eccentric pin in the bearings or simply by inserting shims under the flange plate.



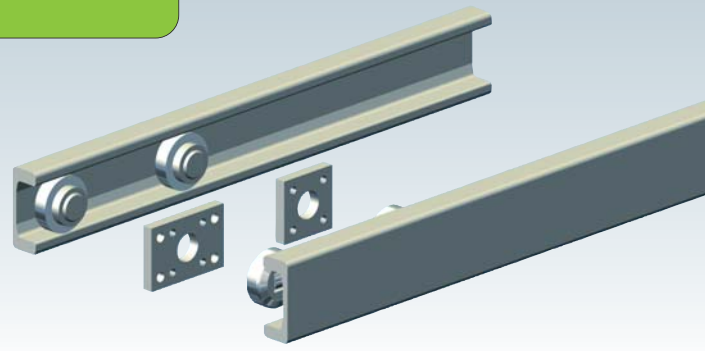

Technical specifications

Determination of the necessary spacing between the bearings

Formula:

$$X = \frac{P \cdot Y}{2 \cdot F_1}$$

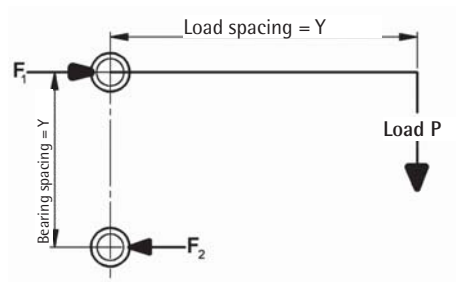

Explanatory notes:

- P: Total load (working load + own weight) in N at central load distribution
- Y: Load spacing (centre of bearing to centre of load) in mm
- X: Bearing spacing in mm
- F1=F2: max. load on the bearing in N, under the application of Hertzian contact stress between bearing and profile

Determination of the necessary load-bearing capacity of the bearings

Formula:

$$F_1 = \frac{P \cdot Y}{2 \cdot X}$$

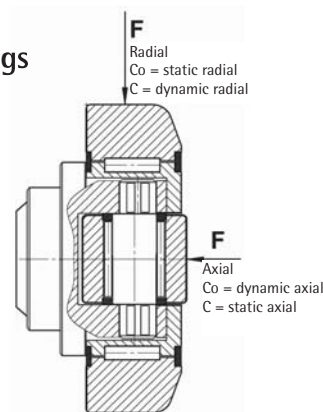

Frictional value

Formula:

$$M_R = f \cdot F \cdot \frac{d_M}{2}$$

Under most operating conditions the approximate frictional power will be sufficient. Depending on the amount of grease present, these values may be higher or lower than stated.

Explanatory notes:

- d_M : Average bearing diameter $(d+D)/2$
- f: Frictional value for cylindrical bearings 0.002
- F: Radial load





environment and people...

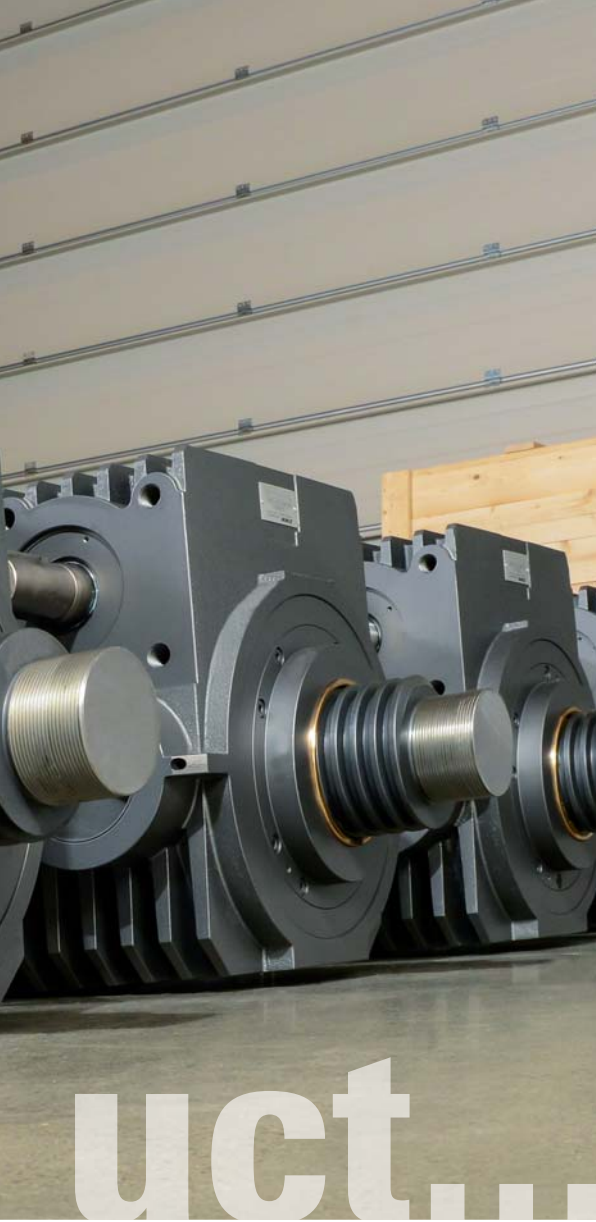

6

in harmony!

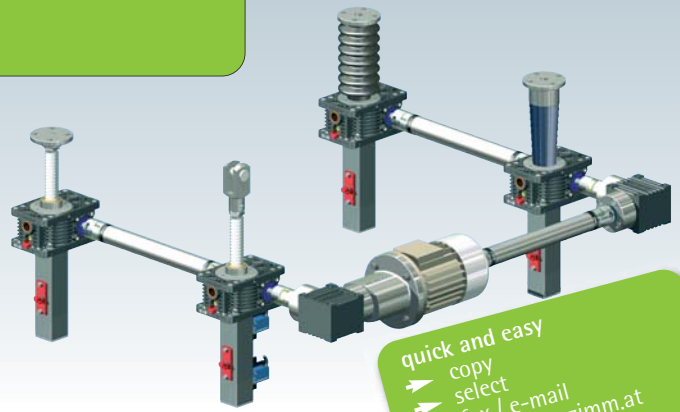

Checklists - Sheet 1 - Parameters

Company: _____ Date: _____
 Address: _____ Phone: _____
 Contact: _____ Fax: _____
 Dept.: _____ E-mail: _____

1. max. lifting force in kN

- per gearbox _____ kN for the entire system _____ kN
 - in tension _____ kN in compression _____ kN
 - Load: static _____ kN dynamic _____ kN

Installation axis

vertical horizontal pivoting

Type of load

smooth impact loads vibration

2. max. lift/travel _____ mm effective working stroke _____ mm

For short stroke applications

(eff. working stroke < gearbox height): regular lubrication stroke practical not practical

3. Lifting speed

type N = 25 mm/s (1.5 m/min) type L = 6.25 mm/s (0.375 m/min) _____ mm/s

4. Duty factor, work cycle, description of cycle

_____ strokes per hour _____ strokes per day Hours per day 8 16 24

i For high duty factors or long strokes, please provide an exact detailed description on page 141, 4a

5. Type S "Translating screw" R "Rotating screw" | Z screw jack GSZ screw jack

6. Motor Three-phase AC motor With brake Manual release _____

7. Operating conditions: Dry Humid Dust Chipping _____ Guided movement No guides (no dyn. lateral forces)

Ambient temperature: min. _____ °C max. _____ °C

i If possible please provide an exact description or sketch on page 141, 7a

8. Standard layouts no.: _____ Size: MA1 _____ MA2 _____ MA3 _____ MA4 _____ MA5 _____

see standard layouts, checklist sheets 5 and 6 (for multi-jack systems)

9. Quantity Required: _____ Series: _____

10. Schedule Quotation: _____ Delivery: _____

Checklists - Sheet 3 - List of components S

- Type:
- SN (Translating screw, normal)
 - SL (Translating screw, low speed)
- Variant:
- Tr screw
 - SIFA safety nut
 - with SIFA monitoring
- KGT ball screw

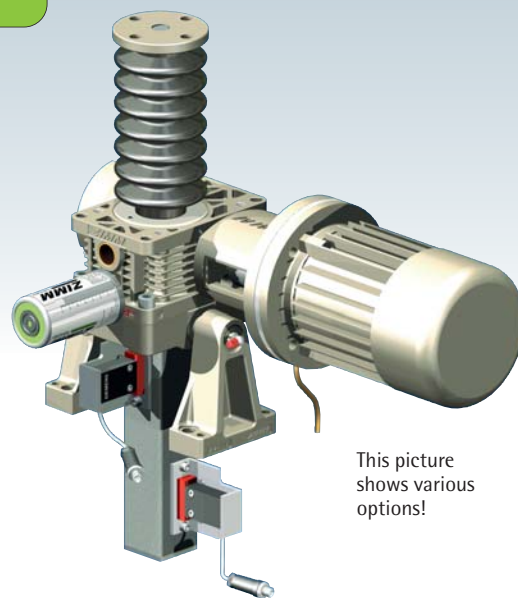

This picture shows various options!

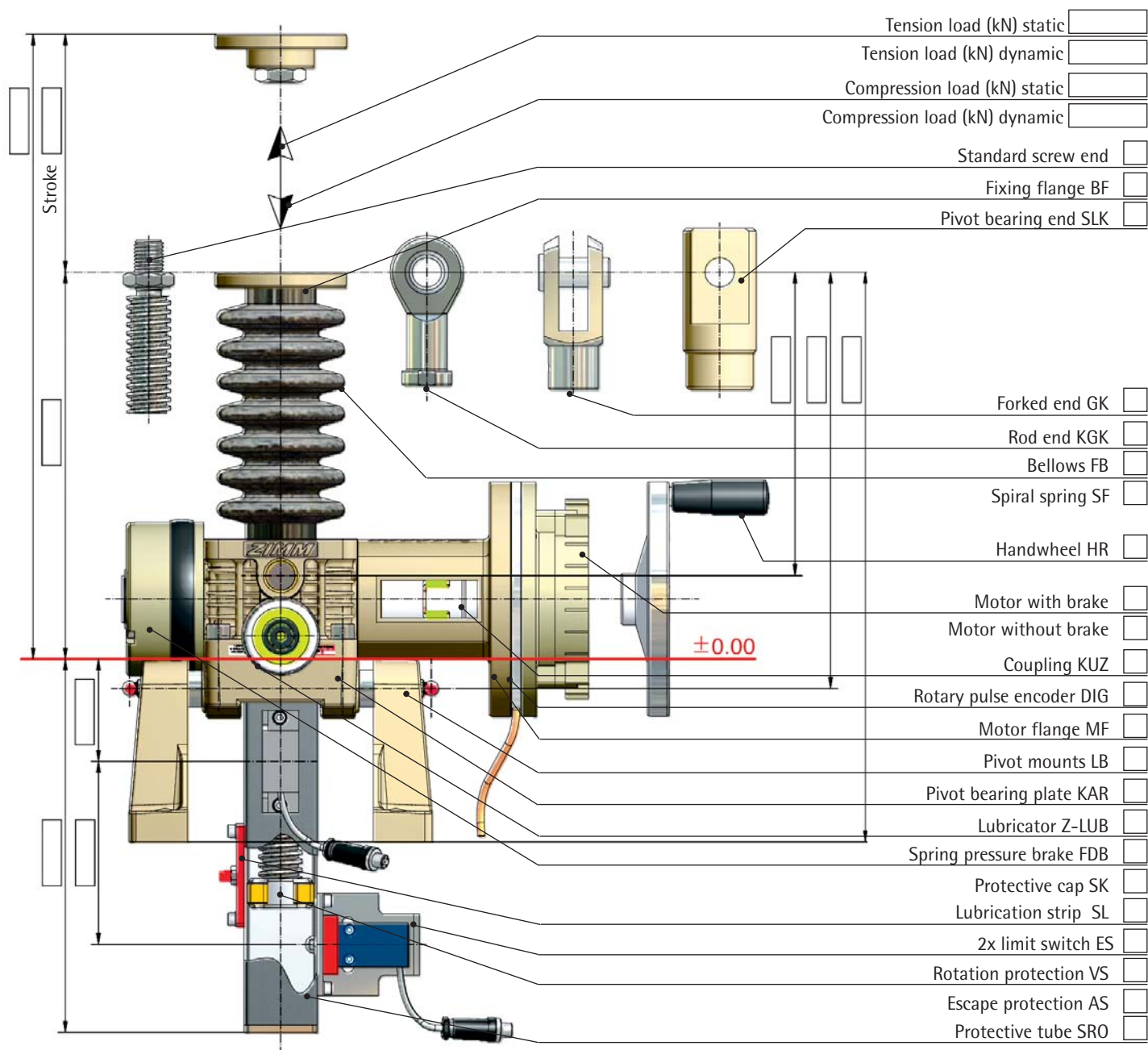

- Tension load (kN) static
- Tension load (kN) dynamic
- Compression load (kN) static
- Compression load (kN) dynamic
- Standard screw end
- Fixing flange BF
- Pivot bearing end SLK
- Forked end GK
- Rod end KGK
- Bellows FB
- Spiral spring SF
- Handwheel HR
- Motor with brake
- Motor without brake
- Coupling KUZ
- Rotary pulse encoder DIG
- Motor flange MF
- Pivot mounts LB
- Pivot bearing plate KAR
- Lubricator Z-LUB
- Spring pressure brake FDB
- Protective cap SK
- Lubrication strip SL
- 2x limit switch ES
- Rotation protection VS
- Escape protection AS
- Protective tube SRO

Checklists - Sheet 4 - List of components R

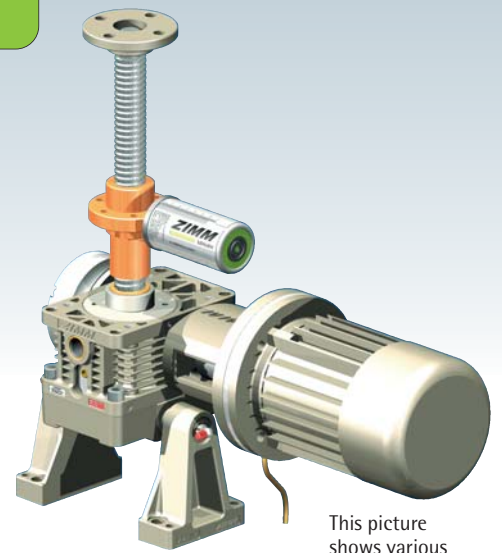

This picture shows various options!

Type:

- RN (Rotating screw, normal)
- RL (Rotating screw, low speed)

Variant:

- Tr screw
- SIFA safety nut
- with SIFA monitoring

- KGT ball screw

Stroke

±0.00

- Tension load (kN) static
- Tension load (kN) dynamic
- Compression load (kN) static
- Compression load (kN) dynamic
- Opposed bearing plate GLP
- Bellows FB
- Spiral spring cover SF
- Lubricator Z-LUB
- Cardan adapter DMA
- Duplex nut DM
- Tr flange nut FM
- KGT flange nut KGT-F
- Self-aligning nut PM
- Greaseless nut FFDM
- Driving flange TRMFL
- Safety nut SIFA
- Wear monitoring SIFA Control
- Handwheel HR
- Motor with brake
- Motor without brake
- Rotary pulse encoder DIG
- Motor flange MF
- Coupling KUZ
- Pivot mounts LB
- Pivot bearing plate KAR
- Spring pressure brake FDB
- Protective cap SK

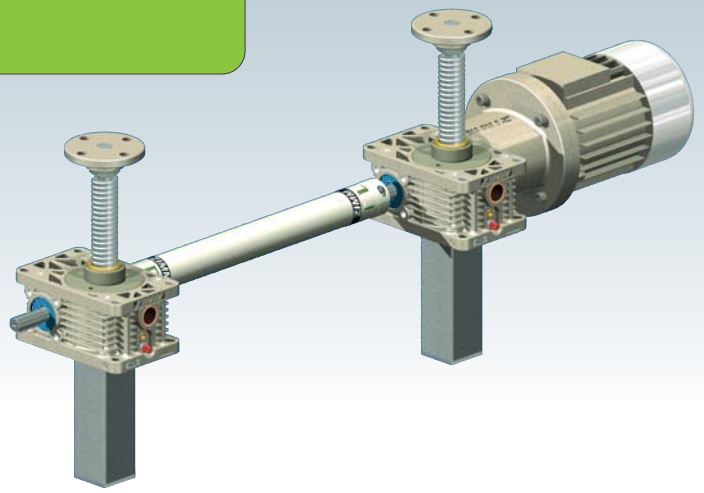

Checklist - Sheet 5 - System layouts

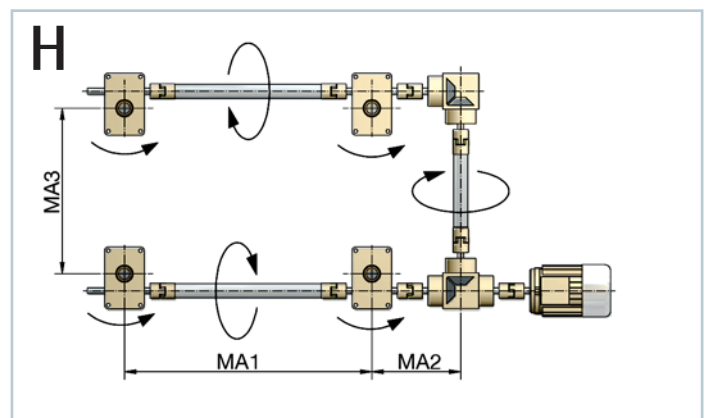
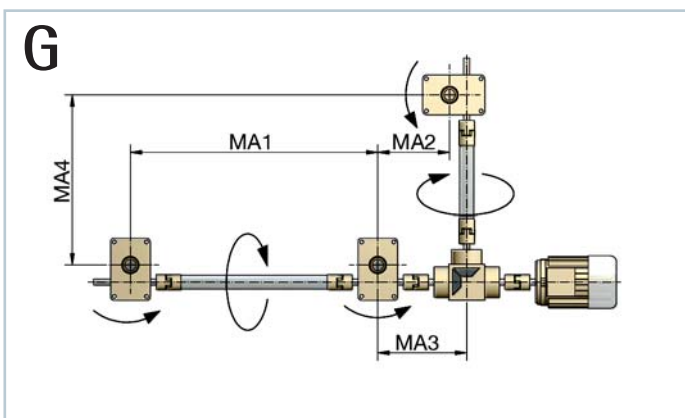
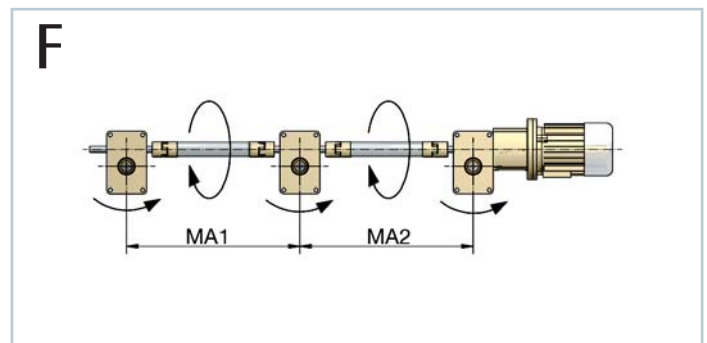
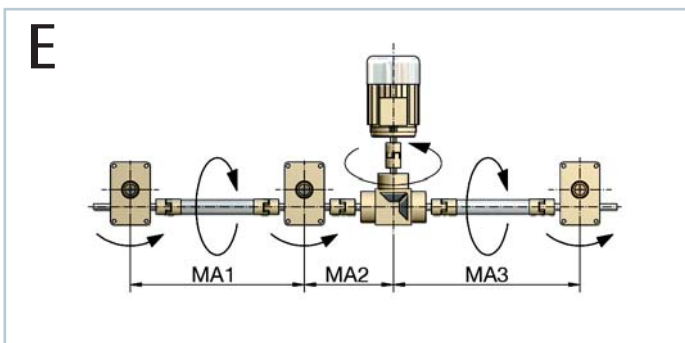
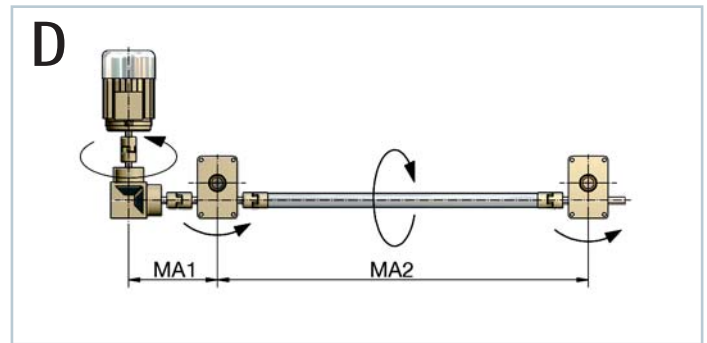
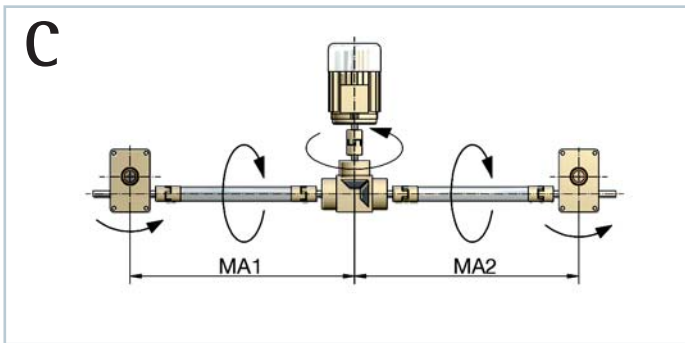
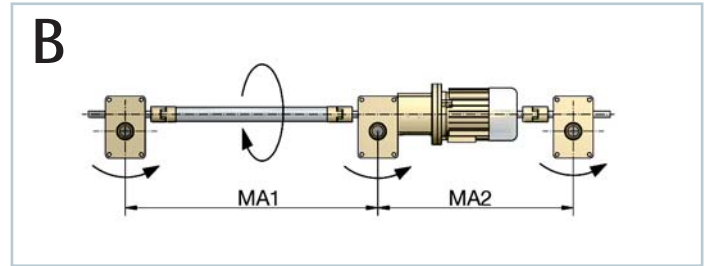
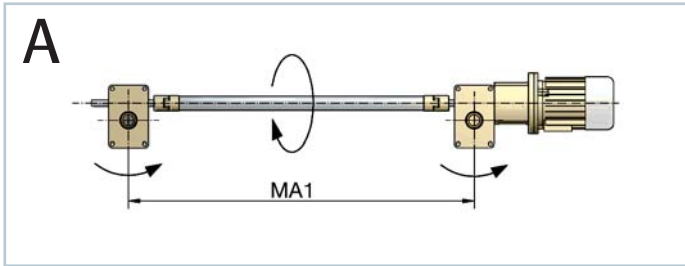

The most common layouts are shown. If your design is different, be sure to check the direction of rotation!

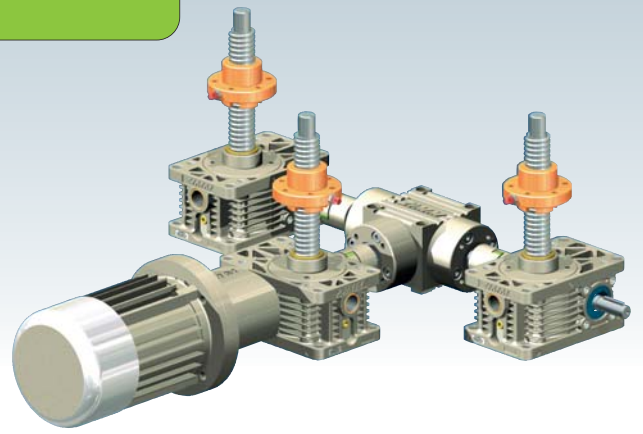

Checklist - Sheet 6 - System layouts

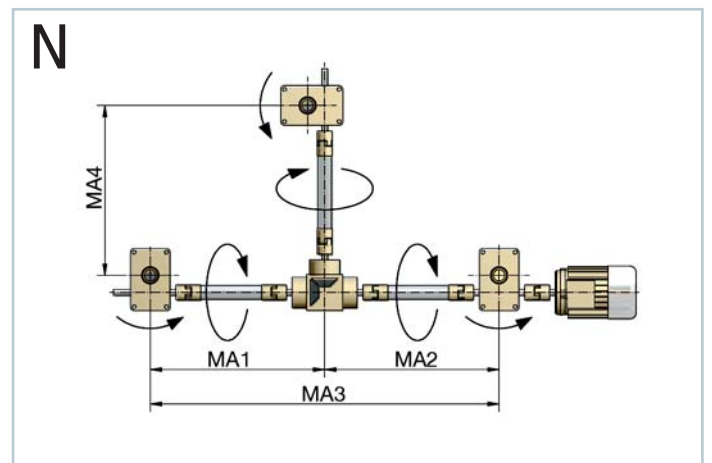
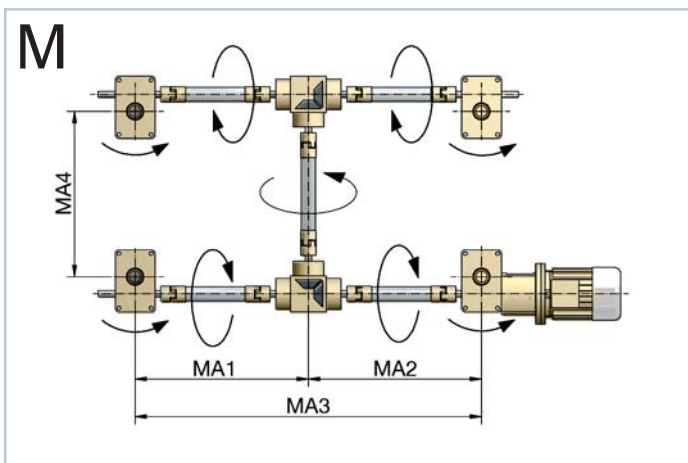
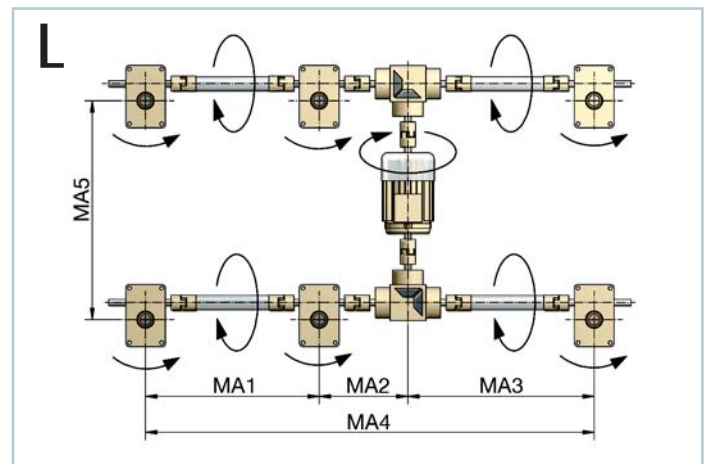
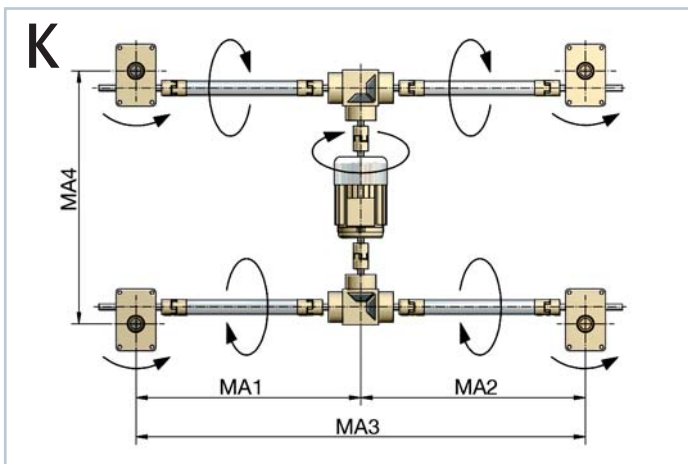
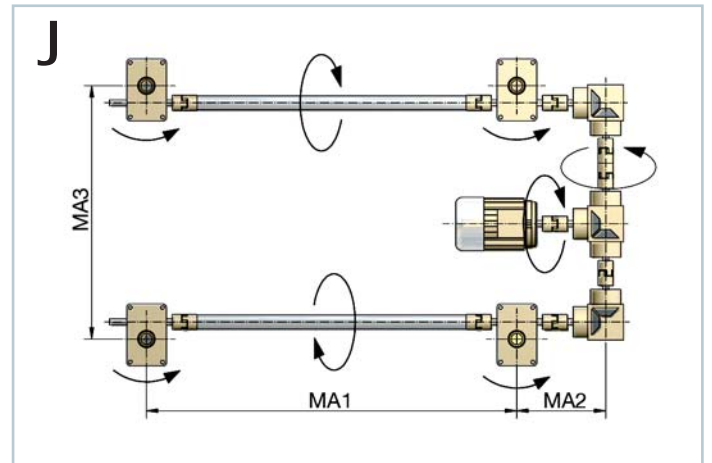
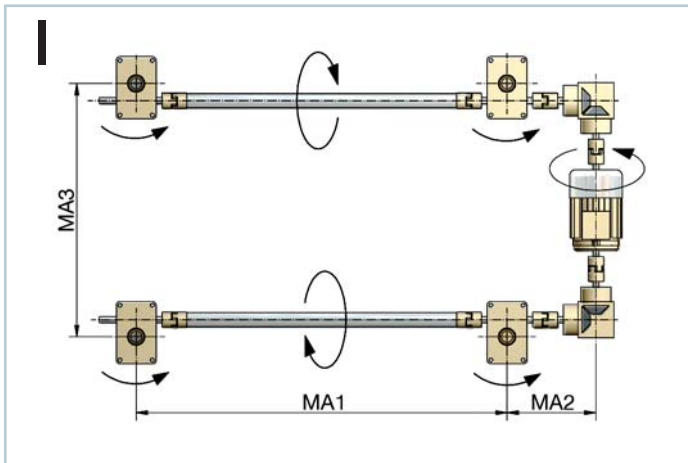

The most common layouts are shown. If your design is different, be sure to check the direction of rotation!

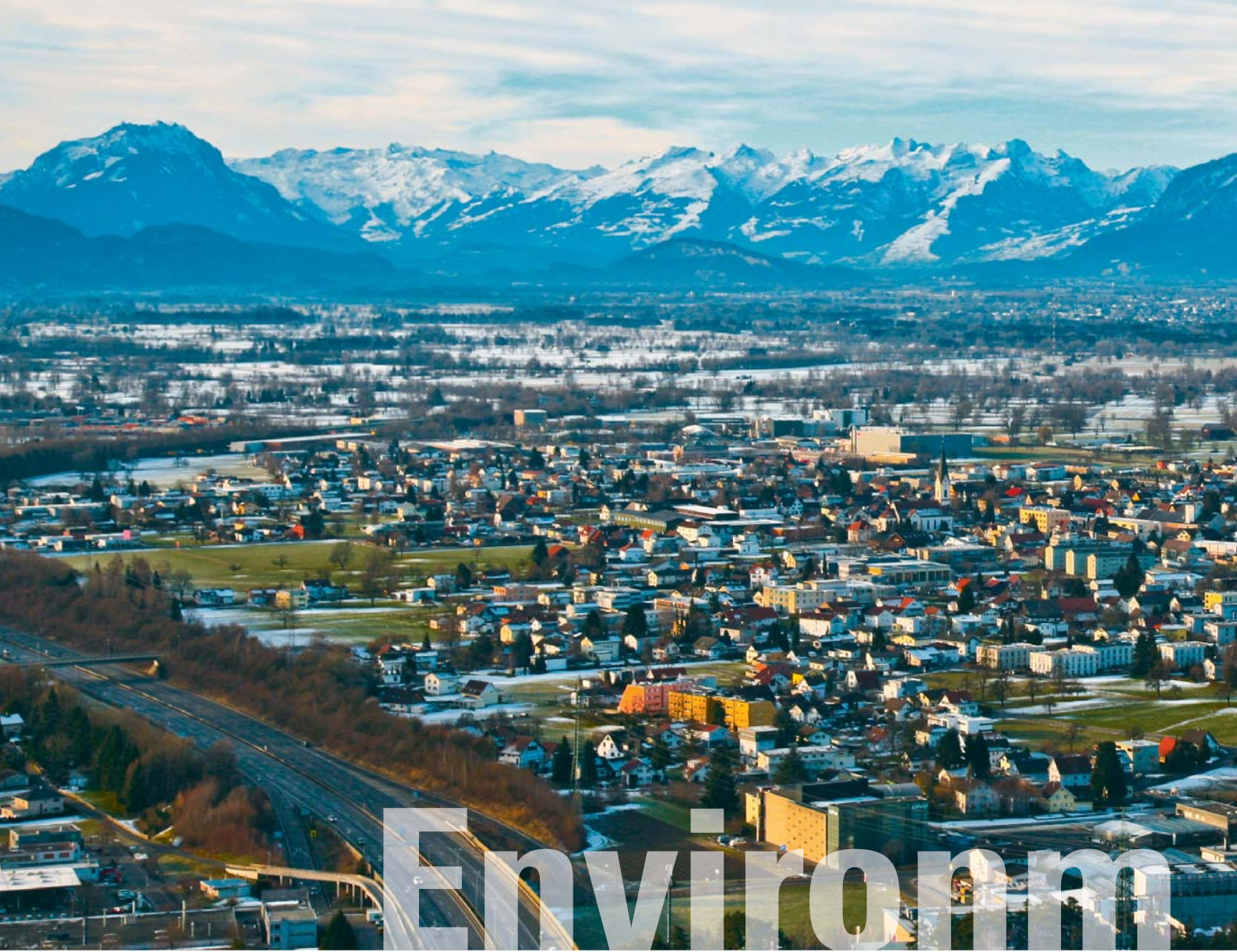

people and product...



in harmony!



Installation, operation, inspection

Correct installation and commissioning is important for reliable operation of the system. Good maintenance is a precondition for a long service life.

Please therefore study the Instruction Manual which are supplied with each delivery and are also available for downloading from: www.zimm.at

Technical appendix

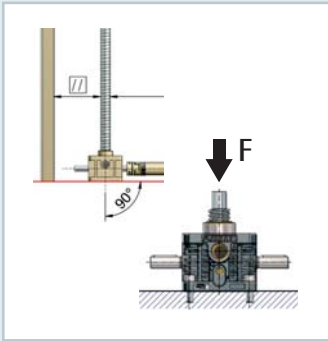

Design advice,
attachment,
permissible loads

Page 150

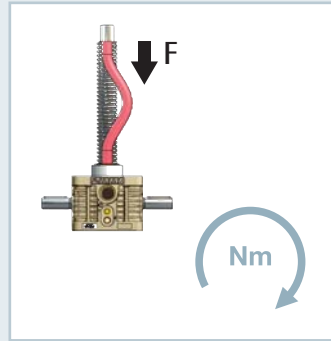

Calculations,
design,
tables

Page 160



Operation,
maintenance

Page 172

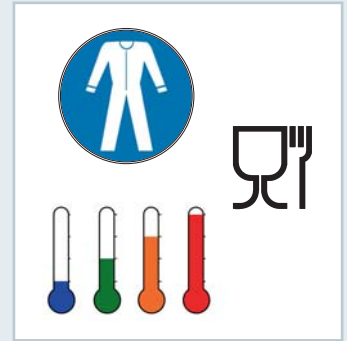

Special application range

Page 176

Design advice

Design and specification

Selection and dimensioning is the customer's responsibility, because we are not familiar with the design criteria such as installation location and type of application. On request we can provide support during selection and specification and make proposals with subassembly drawings and calculations based on your application parameters. You can then examine and approve these drawings and their parts lists.

These then serve as basis for production and preassembly and assist your employees during installation and fitting. We guarantee the quality of the machine elements as described in the catalogue. The gearboxes are designed for industrial use at the loads and duty cycles specified in the catalogue.

If your requirements are not covered by our catalogue descriptions, please contact our project technicians. We generally deliver according to our current Terms of Sales and Delivery (Section 10).

Lifting speed

Lifting speed $v = \frac{\text{Screw pitch } P}{\text{Gear ratio } i} \times \text{motor speed } n$

m/min

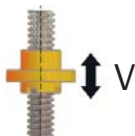

There are several parameters which affect the lifting speed:

Faster:

- double-pitch screw (not generally held in stock): This doubles the lifting speed (CAUTION: max. input torque, not self-locking – brake required!)
- increased screw for the R version (next larger size of gearbox): depending on the screw jack size, this will give a somewhat greater pitch / lifting speed
- Ball screw: Various pitches are available (CAUTION: not self-locking– brake required!)

- Frequency converter serves to increase the motor speed to more than 1500 rpm. Please note the maximum gearbox speed.

Slower:

- Motors with more poles/lower speed (6, 8, 10 or 12 poles)
- Frequency converter (CAUTION: if the motor is to be operated for extended periods at frequencies less than 25 Hz, adequate cooling must be assured, e.g.: separately driven fan)
- Geared motor (CAUTION: do not exceed the maximum input torque)
- Bevel gearbox with gear reduction (only suitable for certain applications)

Temperature and duty cycle

Screw jacks are generally not designed for continuous operation.

Refer to the diagram on the gearbox pages (Sections 2 + 3) for the maximum duty cycles (ED).

These are reference values but vary according to usage conditions. In borderline cases, select a larger screw jack or contact our project technicians.

Operating temperatures must not exceed 60°C (gearbox) or 80°C (screw) (higher values on request).

Rotation protection

On the version S₁, the translating screw is free running within the gearbox (worm wheel).

The screw must be protected against rotation – otherwise it would rotate due to the friction in the worm wheel. This can be achieved by fixing the screw to an external guidance system or by using our rotation protection (VS) (in the protective tube).

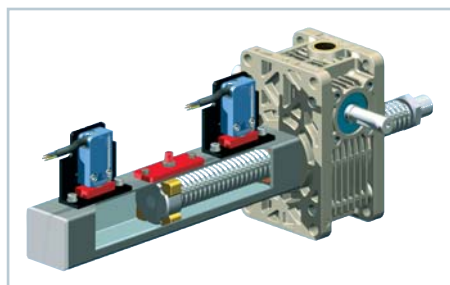

Parallelism and angular relationships

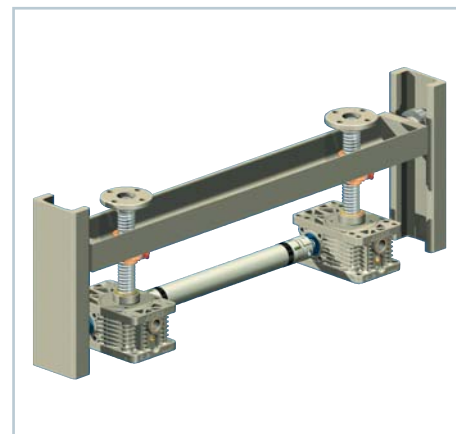

Attention must be paid to the parallelism and correct angular relationships of mounting surfaces, gears, nuts and guides to each other. The same applies for exact alignment of gears, pedestal bearings, connecting shafts and motors to each other.

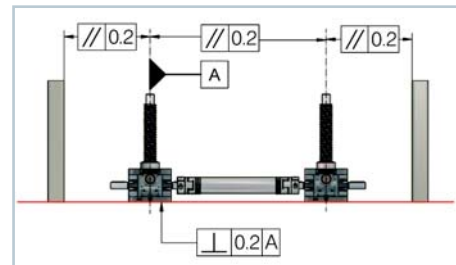

Guides

Guide bush play in the screw jack gearbox can be between 0.2 mm and 0.6 mm depending on the size. This is just a secondary support and does not replace a guide system specifically provided to cater for lateral forces.

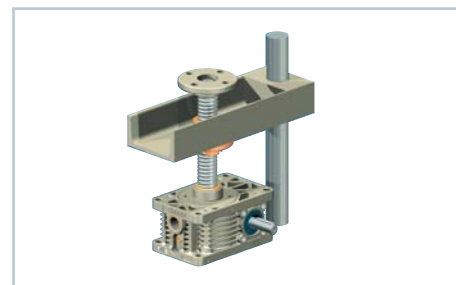

Design advice

Safety distance

Safety distances between moving and stationary components must be maintained otherwise there is the risk of the screw jack reaching a blocked position (see Gearbox Dimension Sheets).

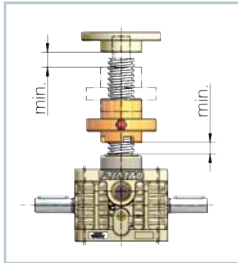

Accuracy

The repetition accuracy of the gearbox can be up to 0.05 mm when moving to the same position again under the same load conditions.

This requires measures on the drive side, such as a 3-phase AC motor with a brake in conjunction with a frequency converter, a rotary pulse encoder or a servomotor with encoder, etc.

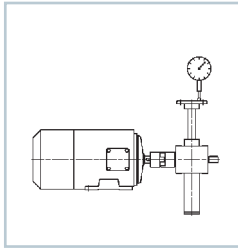

The pitch accuracy for trapezoidal screws is 0.2 mm over a 300 mm screw length, and 0.05 mm for ball screws over a 300 mm screw length.

Under alternating loads, axial play can be up to 0.4 mm on trapezoidal screws and 0.08 mm on ball screws (when new).

Direction of rotation and movement

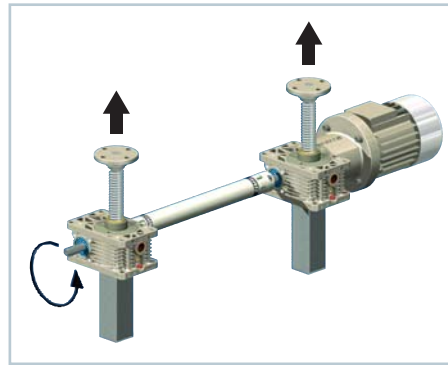

Check the direction of rotation required for the system and record this on the drawing or select one of our standard system layouts (Checklists). With T bevel gearboxes, the direction of rotation can be changed simply by turning the gearbox around.

Self-locking / overrunning

Screw jacks with a single-pitch trapezoidal screw have a limited self-locking capability which cannot always be relied upon, especially where impact loads or vibrations are present (brake recommended).

The overrun after the motor has been switched off varies depending on the application. To minimize overrun, we recommend using a braked motor or a spring pressure brake FDB. A braked motor is essential for double-pitch screws or ball screws, because these are not self-locking.

Drive

We recommend the use of a frequency converter to achieve smooth start-up and brake ramps. This minimizes start-up noise and extends the service life of the gearbox.

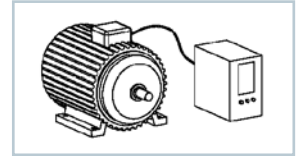

Trial runs!

Trial runs without load and under load in normal operating conditions are necessary to ensure reliable operation. Do not exceed system duty cycle when loaded. These on-site trial runs are necessary to achieve system alignment and to eliminate any factors which may impair operation.

Spare parts

To protect against loss of production caused by high duty cycles or high loads, we recommend keeping a set of screw jack spare parts (including screws, accessories and with assembly drawings) at your location or at your customer's location.

Theatre stage design

We supply lifting equipment which satisfies the current regulations on theatre stage design.

Land vehicles, aircraft and water craft

Our extended warranty terms generally do not apply to machine elements used in any land vehicles, aircraft and water craft. Special individual terms may be agreed on inquiry.

Ambient conditions

Please specify any ambient conditions that are outside normal industrial environmental conditions (Checklists - Section 7).



Design advice

Lubrication

Adequate lubrication is determine for the service life of a screw jack. Therefore ensure adequate lubrication of screws, gearboxes and rotation protection. The red lubrication strip for rotation protection can be mounted in alternative positions to meet your requirements (please specify).



Please also refer to our lubricator and our Instruction manual.

Lubrication for short stroke applications

S version:

For short stroke applications (stroke < gearbox height), take particular care to ensure lubrication of the trapezoidal screw.

The simplest tactic is to specify the screw jack with a longer stroke than the gearbox height, and occasionally perform a lubrication stroke. Otherwise, contact our Engineering Department for a suitable solution.

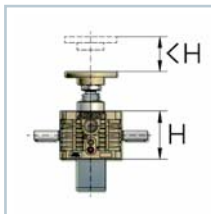

R version:

If stroke length < nut height, use a nut with lubrication capability (such as a duplex nut DM).

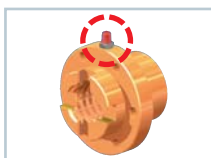

Instruction manual

Please refer to our Instruction manual during the design phase (www.zimm.at).

Design advice for steel and plant construction:

Hardly any assembly problems arise when screw jacks are used in machine tools, because the relevant surfaces are machined faces.

In steel and plant construction however, frequent geometric errors can occur in welded structures, despite accurate fabrication work. The interaction between different components can also cause alignment issues. Attention must be paid to the following:

Parallelism / angular relationships:

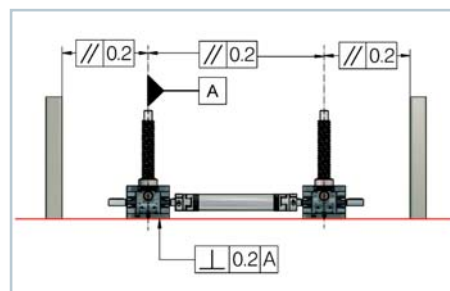

Screws and guides must be parallel to each other, otherwise the equipment can seize up during operation. All mounting surfaces for the gearboxes must be exactly at right angles to the guides, jamming may occur, leading to rapid wear and/or serious damage.

Squeaking noises can also occur on R versions. The mounting surfaces for the nuts must also be at right angles.

ZIMM has developed the self-aligning nut PM (see Section 4) to save time and costs here.

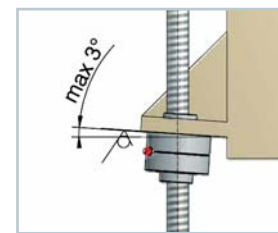
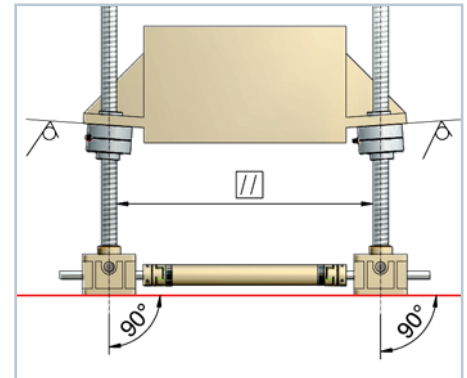
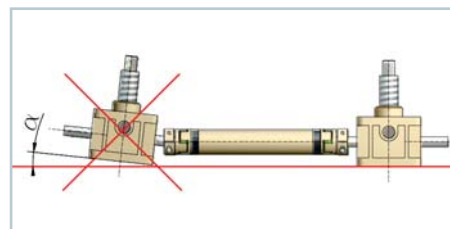

Additional features where alignment may be a problem are the integrated pivot bushings in the gearbox or the pivot bearing plate KAR (see Section 4).

For steel and plant construction:

We supply standard heavy-duty linear guides including bearings. Their stability, long service life, avoidance of geometric errors and ability to accept lateral side forces are decisive arguments for using such guides.

See Section 6 for linear guides.



 Printing errors, dimensional mistakes etc. and also technical changes and improvements are excepted. Drawings are valid only when they have been checked and approved by both partners in accordance with the order acknowledgement.

Specification of a screw jack or lifting system – procedure

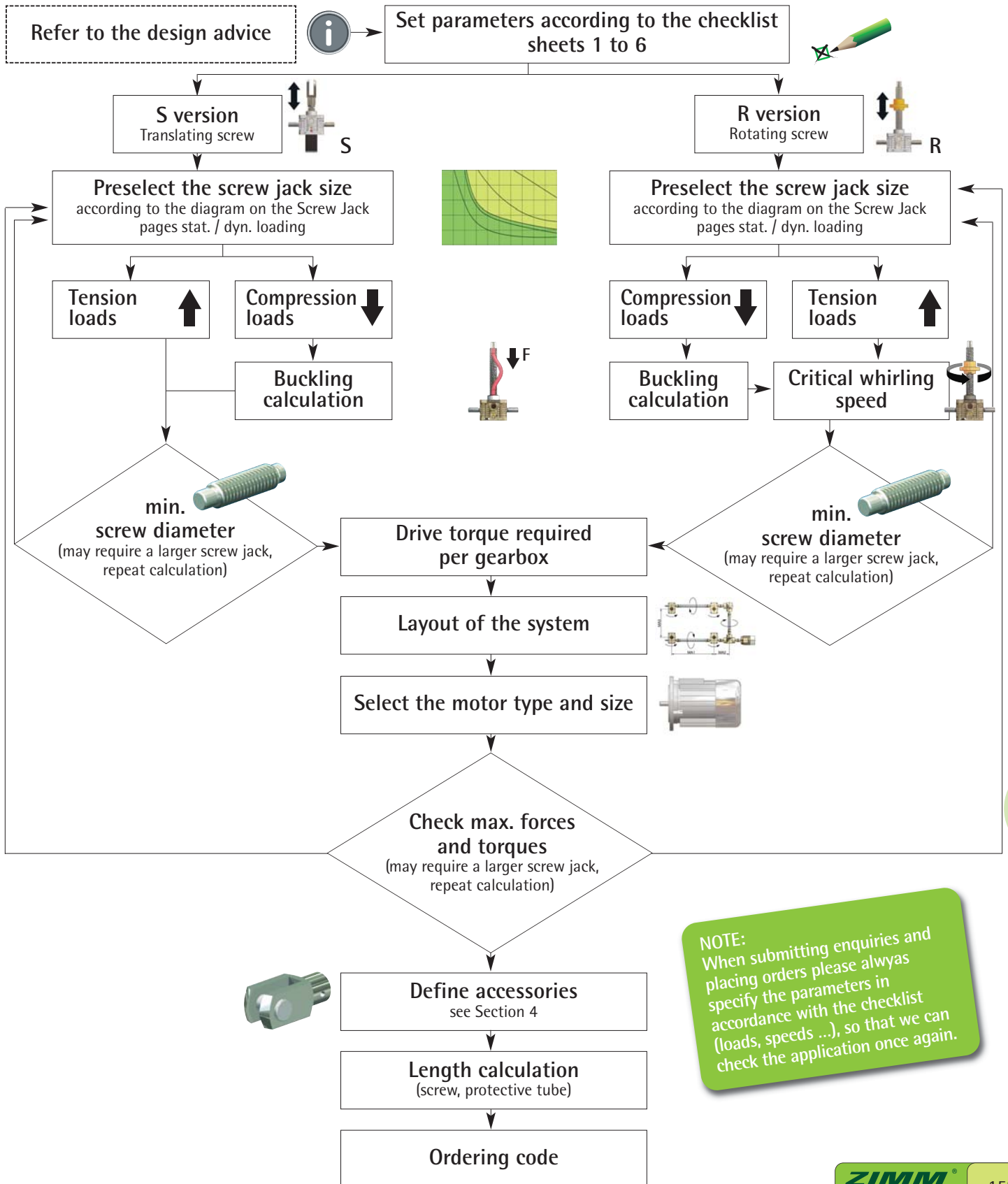

NOTE:
When submitting enquiries and placing orders please always specify the parameters in accordance with the checklist (loads, speeds ...), so that we can check the application once again.

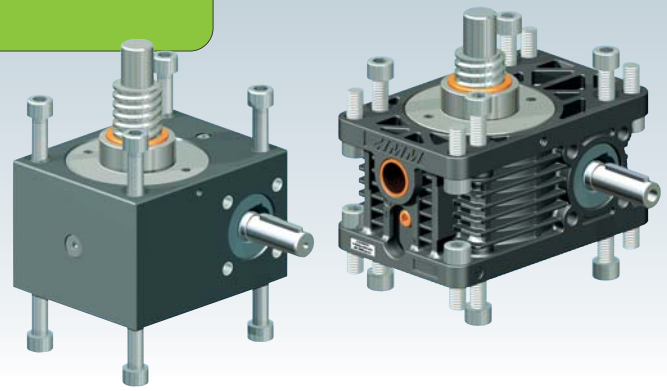

Fixing - fixed

From above:



Through screws
(for the Z series)

The great advantage of the Z series is that it can easily be attached from above.

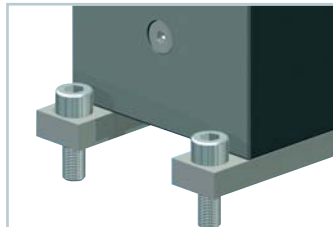

Fixing strips
(for the GSZ series)

Top mounting fixing strips BFL are required for attaching GSZ gearboxes from above.

Through the mounting plate:

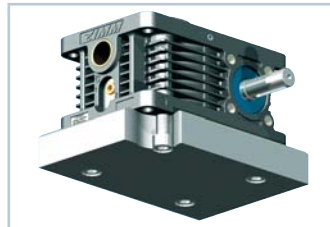

Blind tapped holes
(Z and GSZ series):

Z and GSZ series can be attached from underneath using the blind tapped holes in the gearbox.

GSZ: all sizes

Z: Z-5 to Z-25 (holes the same size as the previous MSZ gearboxes)

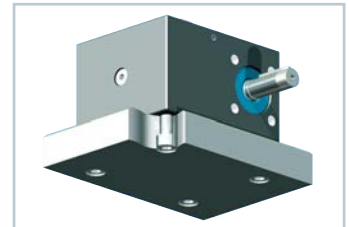

Fixing - pivoting

Duplex nut adapter DMA

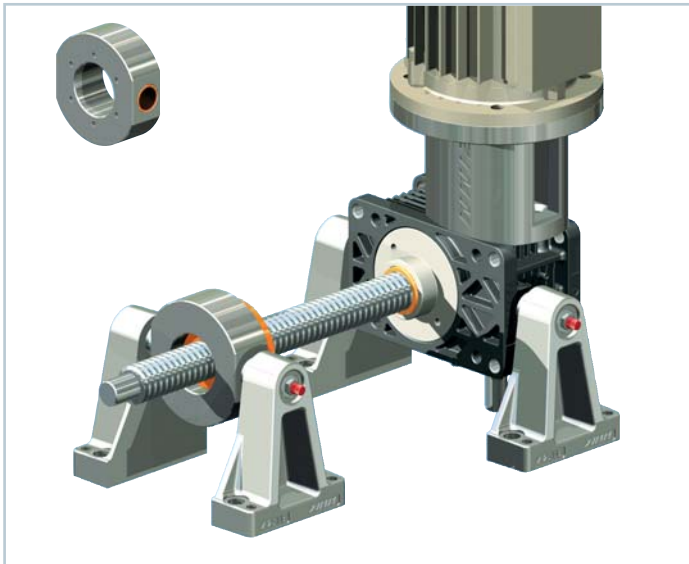

The duplex nut adapter DMA is simply bolted to the duplex nut DM. The pivot can be made with the pivot mounts LB or a mounting designed by the customer.

Pivoting support tube STRO

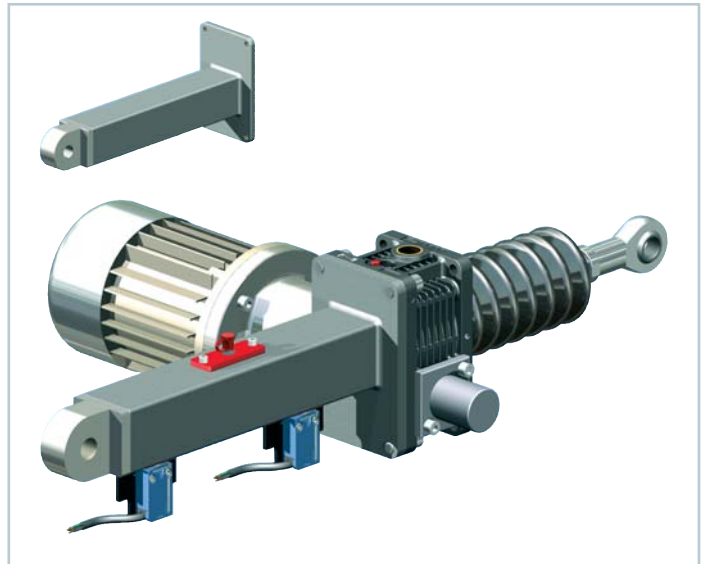

The pivoting support tube STRO has the advantage that the pivot points are entirely external. The disadvantage is that the gearbox and motor weights are in the centre. The manufacture is always customer-specific.

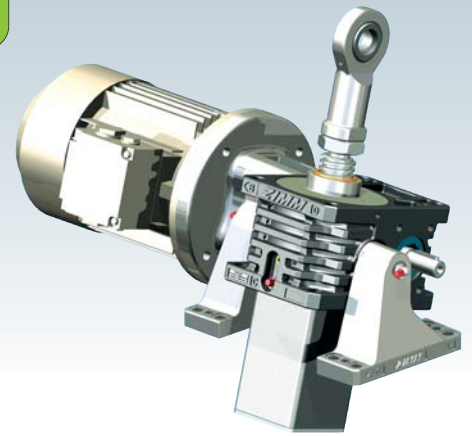

Fixing - pivoting

Z-5 to Z-25

Integrated pivot bearing

Simple and economical design: Pivot bushes are incorporated in the gearbox housing.

With pivot bearing plate KAR

For large motors, long strokes and high load cycles, the variant with the pivot bearing plate KAR is preferable, because the weight of the motor is then taken by the bearing points and does not affect the screw.

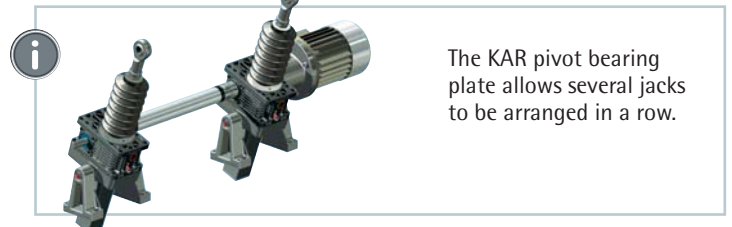
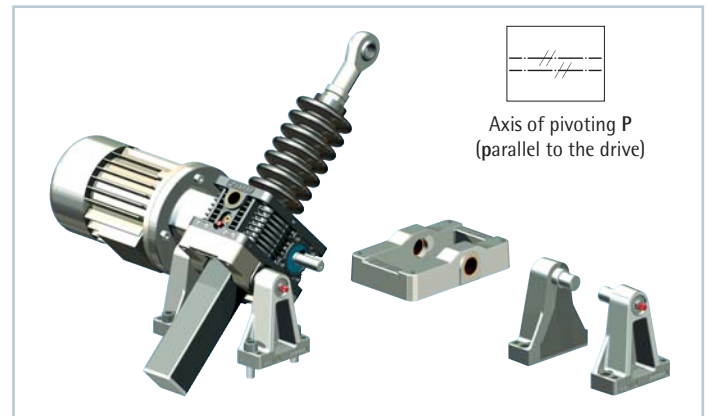
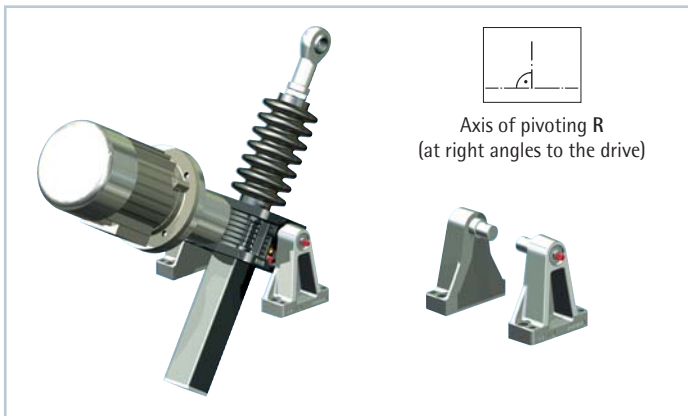

Z-35 to Z-1000

Integrated pivot bearing

Simple and economical design: Pivot bushes are incorporated in the gearbox housing.

GSZ-2 to GSZ-100

With pivot bearing plate KAR

For GSZ gearboxes, a pivot bearing plate can be mounted on face E (above) or F (underneath). In each case there are 4 holes available for the pivot plate P or R.

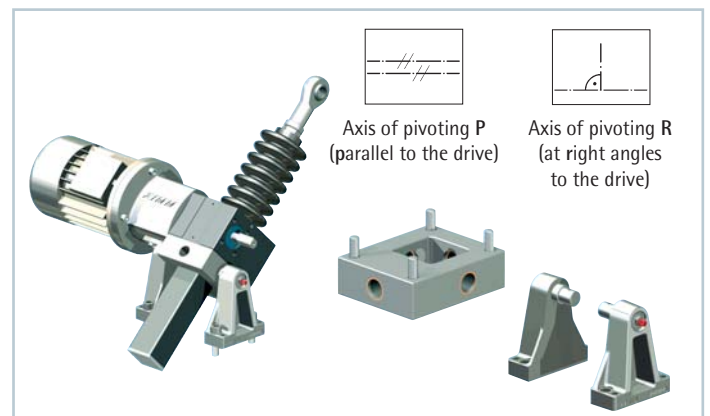
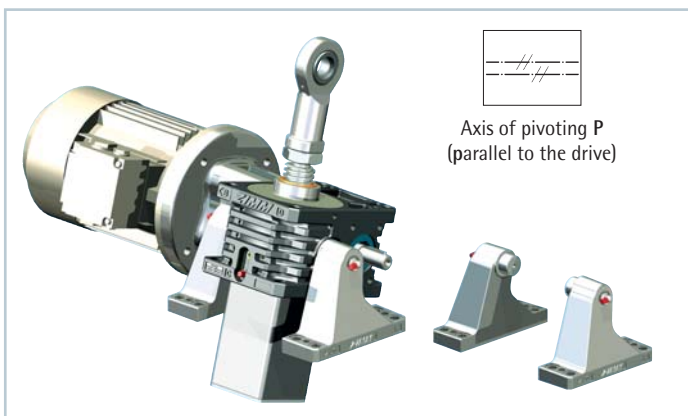

Pivot bearing plate KAR on request

Permissible loads - fixed

The screw jacks themselves are specified for full static nominal load under tension and compression. The permissible load depends on the type of fastening.

Compressive load

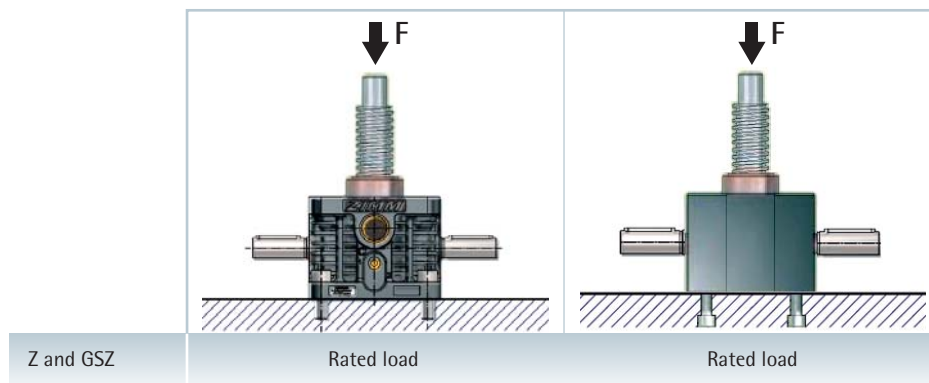

Full rated load
The gearbox can accept the full static rated load.

Mounting plate with tensile load

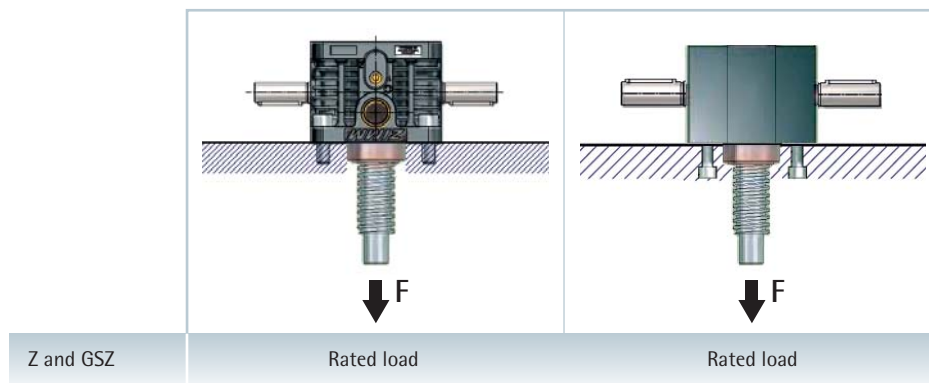

Full rated load
The gearbox can accept the full static rated load.

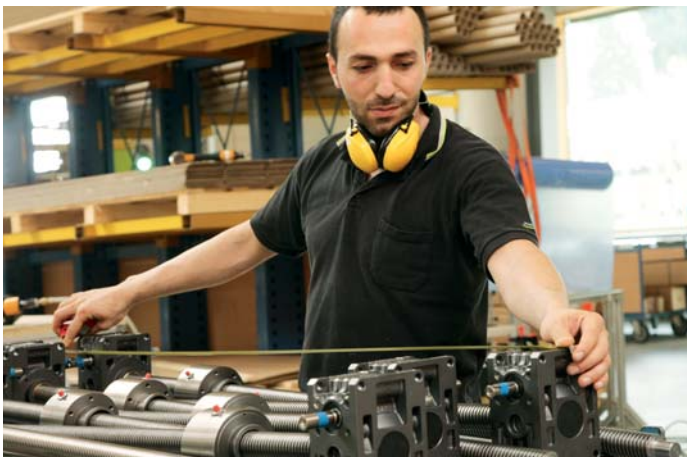

Permissible loads - fixed

Tensile load on the fixing screws (blind tapped holes) - Z and GSZ

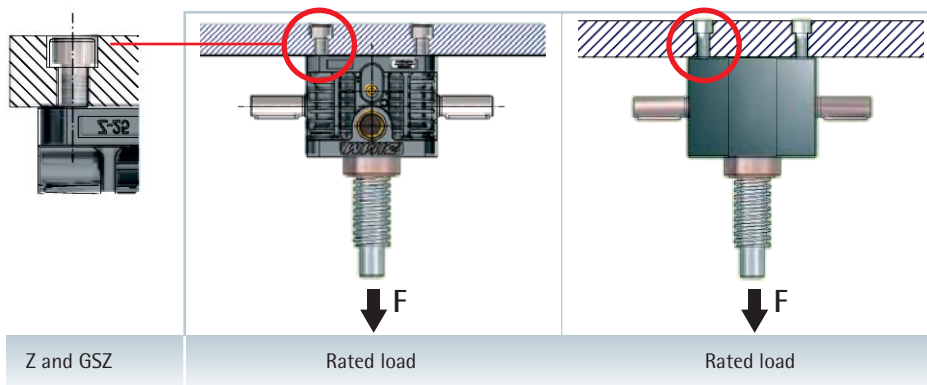

Full rated load

Providing the screw-in depth is maintained and the screws are tightened to the full tightening torque, the full rated load is permissible.

Gearbox	Thread*	Screw-in depth [mm]	Tightening torque [Nm]
GSZ-2	M6	8 to 10	8
GSZ-5, Z-5	M8	10 to 11.5	19
GSZ-10, Z-10	M8	10 to 15	17
GSZ-25, Z-25	M10	12 to 15	27
GSZ-50	M12	12 to 17	38
GSZ-100	M16	16 to 22	82

Tensile load on the fixing screws (through holes in the housing)

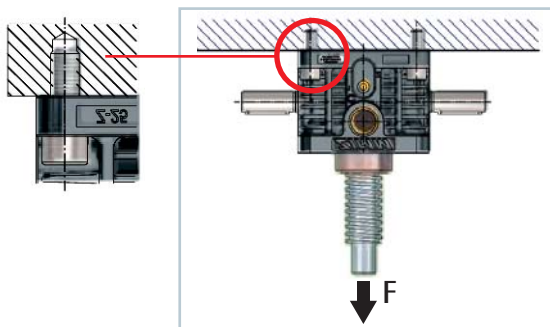

Screws 8.8

Reduced load

If the fixing screws on the housing are loaded in tension, only reduced loads are permissible.



For higher loads in tension, we can offer certain solutions on request.

Gearbox	Permissible load
Z-5	2.5 kN
Z-10	3.5 kN
Z-25	10.0 kN
Z-35	29.8 kN
Z-50	27.5 kN
Z-100	27.0 kN
Z-150	56.5 kN
Z-250	70.0 kN
Z-350	180.0 kN
Z-500	110.0 kN
Z-750	210.0 kN
Z-1000	on request



Permissible loads - pivoting

When dimensioning, include all the parts you will use

Z-5 to Z-25 - Pivot bearing in the housing

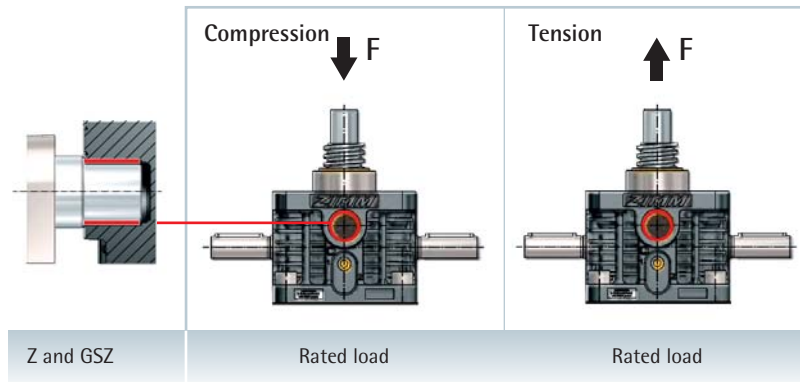

Z-5 to Z-25 - Pivot mounts LB

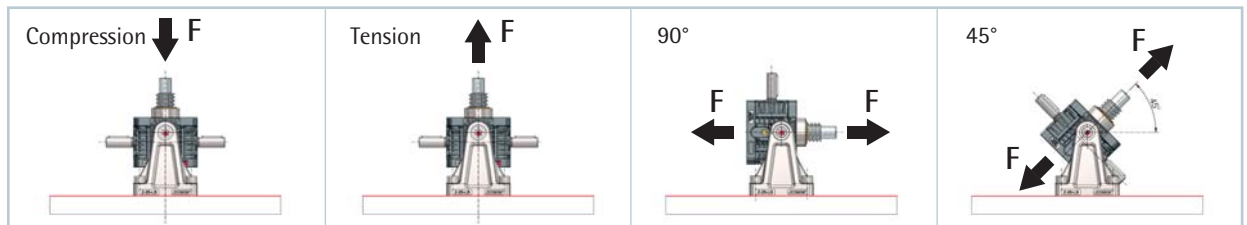

Z-5 (Z-5/10-LB)	Rated load 5 kN	Rated load 5 kN	Rated load 5 kN	Rated load 5 kN
Z-10 (Z-5/10-LB)	Rated load 10 kN	Rated load 10 kN	7 kN	6.5 kN
Z-25 (Z-25-LB)	19.5 kN	17.5 kN	10 kN	9.5 kN

Z-5 to Z-25 - Pivot bearing plate KAR

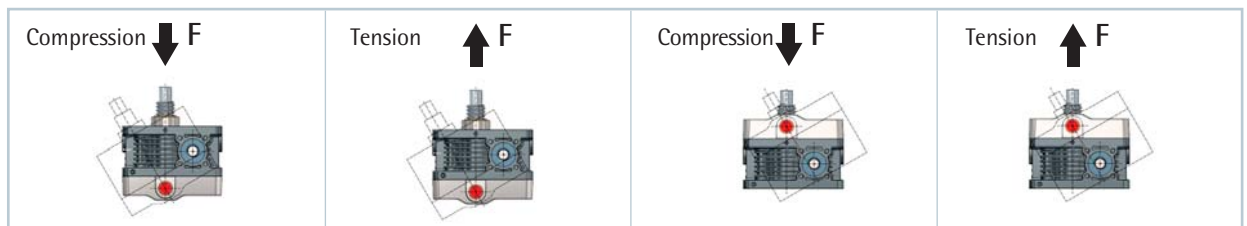

Z-5-KAR	Rated load 5 kN	2.5 kN	2.5 kN	Rated load 5 kN
Z-10-KAR	Rated load 10 kN	3.5 kN	3.5 kN	Rated load 10 kN
Z-25-KAR	Rated load 25 kN	10 kN	10 kN	Rated load 25 kN

Direction of loading

The direction of loading should be selected so that the gearbox is pressed against the pivot bearing plate. When the load is in the opposite direction, reduced load values apply.

Permissible loads - pivoting

The gearbox housing is relevant to the specification.
The pivot mounts Z-35 to Z-1000 are specified for the full rated load in both directions.

Z-35 to Z-1000 – Pivot bearing in the housing

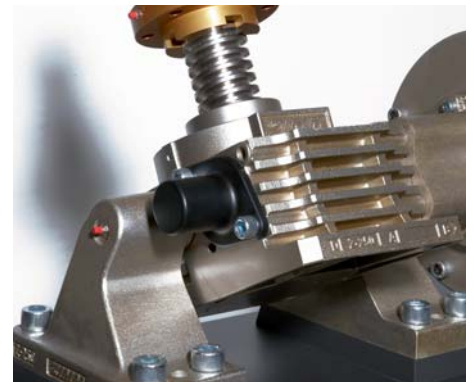
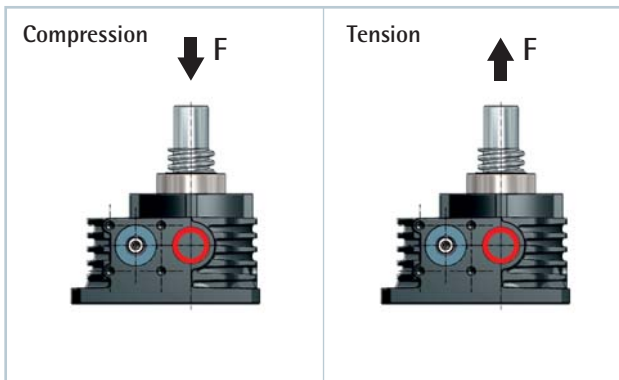

Z-35	Rated load	35 kN	Rated load	35 kN
Z-50	Rated load	50 kN	Rated load	50 kN
Z-100	Rated load	100 kN	Rated load	100 kN
Z-150	Rated load	150 kN	Rated load	150 kN
Z-250		177 kN	Rated load	250 kN
Z-350		250 kN		260 kN
Z-500		280 kN		310 kN
Z-750		on request		on request
Z-1000		on request		on request

Z-35 to Z-1000 – Pivot mount LB

From Z-500 the gearbox is mounted the opposite way round, since the footplate is broader than the rest of the housing:

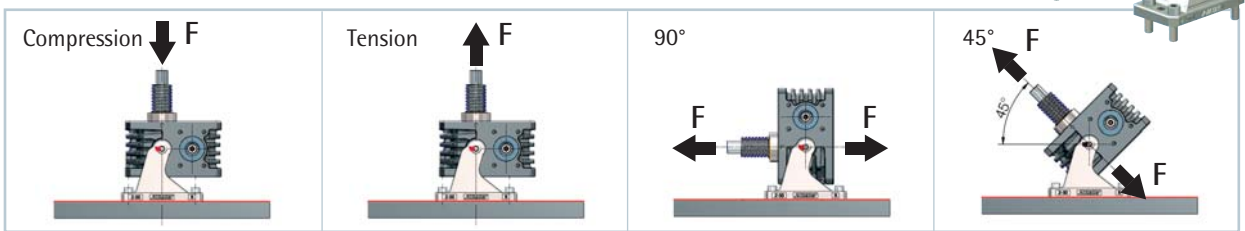

Z-35 to Z-1000	Rated load	Rated load	Rated load	Rated load
----------------	------------	------------	------------	------------

Duplex nut adapter DMA

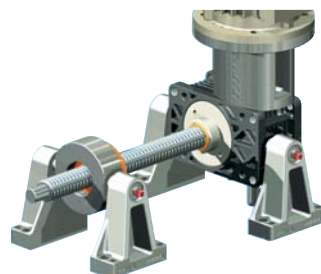
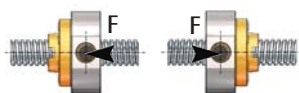

Main direction of loading
Select the main direction of loading so that tensile loads on the nut are avoided.

Support tube STRO

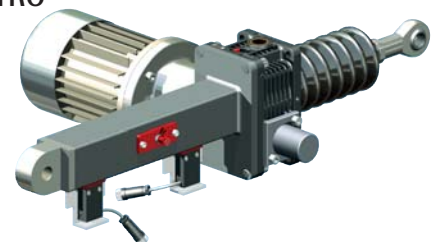

In compression the full rated load permissible. In tension the support tube should be subjected only to limited loads.

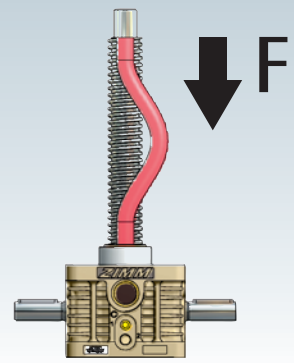

Critical buckling force of the screw

Explanatory notes:

I = 2nd moment of area expressed in mm^4
 F = Max. load/gearbox in N
 L = Free screw length in mm
 E = Modulus of elasticity for steel ($210,000 \text{ N/mm}^2$)
 v = Safety factor (normally 3)
 d = Minimum core diameter of the screw

Example:

$F = 45,000 \text{ N/gearbox}$
 $L = 1320 \text{ mm}$
 $v = 3$

Euler 1

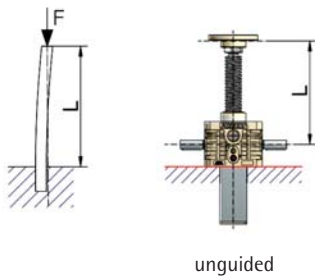

Formula:

$$I = \frac{F \times v \times (L \times 2)^2}{\pi^2 \times E} \quad \text{then} \quad d = \sqrt[4]{\frac{I \times 64}{\pi}}$$

Example:

$$I = \frac{45,000 \text{ N} \times 3 \times (1,320 \text{ mm} \times 2)^2}{\pi^2 \times 210,000 \text{ N/mm}^2} = \frac{9.0896^{11} \text{ mm}^4}{2,072,616.924} = 453,965.22 \text{ mm}^4$$

$$d = \sqrt[4]{\frac{453,965.22 \text{ mm}^4 \times 64}{\pi}} = 55.15 \text{ mm minimum core diameter}$$

= Z-250 (screw core $\varnothing = 59.6 \text{ mm}$)

Euler 2

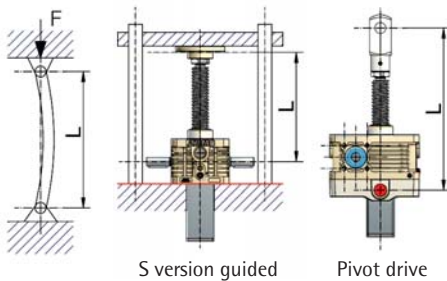

Formula:

$$I = \frac{F \times v \times L^2}{\pi^2 \times E} \quad \text{then} \quad d = \sqrt[4]{\frac{I \times 64}{\pi}}$$

Example:

$$I = \frac{45,000 \text{ N} \times 3 \times (1,320 \text{ mm})^2}{\pi^2 \times 210,000 \text{ N/mm}^2} = \frac{2.35224^{11} \text{ mm}^4}{2,072,616.924} = 113,491.305 \text{ mm}^4$$

$$d = \sqrt[4]{\frac{113,491.305 \text{ mm}^4 \times 64}{\pi}} = 38.99 \text{ mm minimum core diameter}$$

= Z-100 (screw core $\varnothing = 43.6 \text{ mm}$)

Euler 3

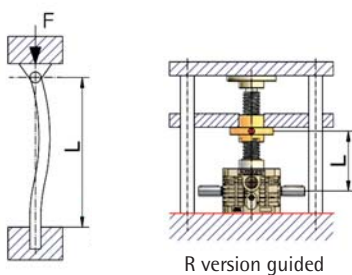

Formula:

$$I = \frac{F \times v \times (L \times 0.7)^2}{\pi^2 \times E} \quad \text{then} \quad d = \sqrt[4]{\frac{I \times 64}{\pi}}$$

Example:

$$I = \frac{45,000 \text{ N} \times 3 \times (1,320 \text{ mm} \times 0.7)^2}{\pi^2 \times 210,000 \text{ N/mm}^2} = \frac{1.15259^{12} \text{ mm}^4}{2,072,616.924} = 55,610.7396 \text{ mm}^4$$

$$d = \sqrt[4]{\frac{55,610.739 \text{ mm}^4 \times 64}{\pi}} = 32.62 \text{ mm minimum core diameter}$$

= Z-50/Tr50 (screw core $\varnothing = 39.8 \text{ mm}$)

	GSZ-2	Z-5	Z-10	Z-25	Z-35/50	Z-50/Tr50	Z-100	Z-150	Z-250	Z-350	Z-500	Z-750	Z-1000
Trapezoidal screw Tr	16x4	18x4	20x4	30x6	40x7	50x8	55x9	60x9	80x16	100x16	120x16	140x20	160x20
Core \varnothing in mm (minimum)	10.9	12.9	14.9	22.1	31.0	39.8	43.6	48.6	59.6	80.6	99.6	115.0	135.0
Ball screw KGT \varnothing mm	16	16	25	32	40	-	50	63	80	100	125	140	160
Core \varnothing in mm (minimum*)	12.9	12.9	21.5	27.3	34.1	-	43.6	51.8	67	87.4	107.8	117	132.8

*Depending on the pitch, the core \varnothing may be even larger. See the KGT pages in Sections 2 and 3 for the exact core \varnothing values.

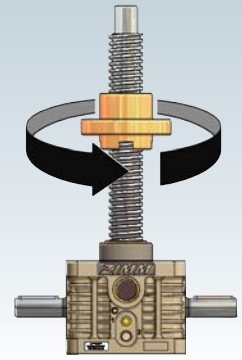

Critical whirling speed for R gearboxes

Maximum permissible screw rotational speed

$$n_{zul} = 0.8 \times n_{kr} \times f_{kr}$$

n_{zul} Maximum permissible screw speed (rpm)

n_{kr} Theoretical critical screw speed (rpm) leading to resonant vibrations (see diagram)

f_{kr} Correction factor which makes allowance for the type of screw bearing

i The operating rotational speed must not exceed 80% of the maximum rotational speed

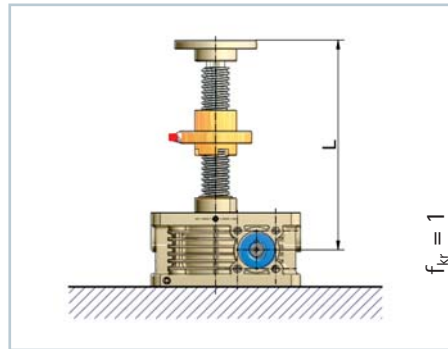

with end mounted bearings
(preferred solution)

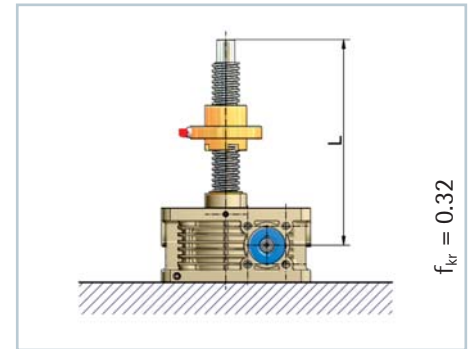

without end mounted bearings
(avoid as far as possible)

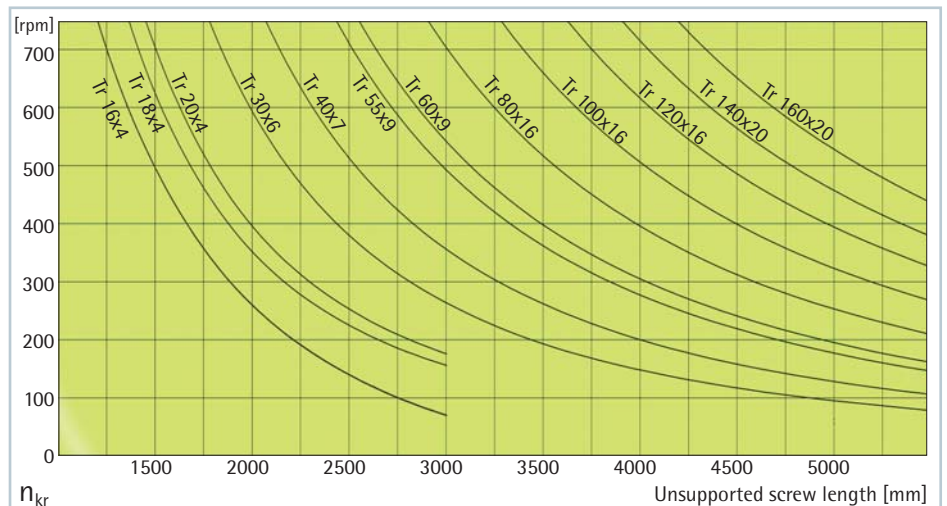

$$\text{Screw speed} = \frac{\text{Input drive speed}}{i_{\text{gearbox}}}$$

The maximum allowable screw speed must be calculated for R version gearboxes (with rotating screws) with long thin screws. To do this, read the theoretical critical speed n_{kr} from the diagram. Take into account also the additional lengths for screw covers etc. when calculating unsupported screw lengths. Now use the formula together with the correction factor for the screw bearing arrangement to calculate the maximum allowable screw speed.

If the calculated maximum screw speed is lower than the required speed, select a larger screw or a double-pitch screw with half the speed. This must then be checked also. You have the option to use a "increased screw" for the R version (screw for the next larger gearbox).

Bear in mind that a larger pitch demands a higher drive torque.

CAUTION:

Long, thin screws can tend to squeak even though they satisfy the critical whirling speed! Therefore allow a sufficient margin of safety in the calculation.

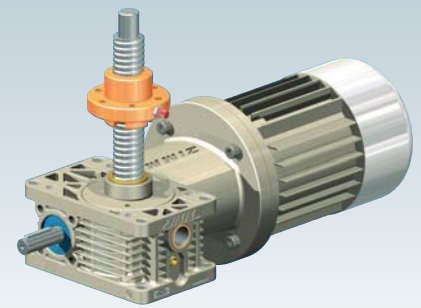

Determining the drive torque [M_G] of a single screw jack

Explanatory notes:

M_G	necessary drive torque [Nm] for a screw jack
F	Lifting load (dynamic) [kN]
η_{gearbox}	Efficiency of the screw jack (without screw)
η_{screw}	Efficiency of the screw
P	Screw pitch [mm]
i	Drive ratio of the screw jack
M_L	Idling torque [Nm]
P_M	Motor drive power

The following specifications serve to calculate the required drive torque.

For gearboxes with single-pitch trapezoidal screws the load can simply be multiplied by the factor stated on the corresponding gearbox page (Sections 2 + 3).

Use at least 10% of the gearbox rated load for the calculation, even if the effective load is less than this (i.e. for the Z-250 use at least 25 kN).

Formula:

$$1) \text{ Drive torque: } M_G = \frac{F \text{ [kN]} \cdot P \text{ [mm]}}{2 \cdot \pi \cdot \eta_{\text{gearbox}} \cdot \eta_{\text{screw}} \cdot i} + M_L \text{ [Nm]}$$

$$2) \text{ Motor power: } P_M \text{ [kW]} = \frac{M_G \text{ [Nm]} \cdot n \text{ [rpm]}}{9550}$$

3) We recommend multiplying the calculated value by a safety factor of 1.3 to 1.5 (up to 2 for small systems and for low speeds).



Example:

Z-25-SN

$F = 12 \text{ kN}$ (dynamic lift load)

$\eta_{\text{gearbox}} = 0.87$ $\eta_{\text{screw}} = 0.391$

$P = 6$ $i = 6$

$$1) M_G = \frac{12 \text{ kN} \cdot 6 \text{ mm}}{2 \cdot \pi \cdot 0.87 \cdot 0.391 \cdot 6} + 0.36 \text{ Nm} = 5.97 \text{ Nm}$$

$$2) P_M = \frac{5.97 \text{ Nm} \cdot 1500 \text{ rpm}}{9550} = 0.938 \text{ kW}$$

3) Example: $0.938 \text{ kW} \cdot 1.5 = 1.407 \text{ kW} \rightarrow$ motor 1.5 kW

Efficiencies of the screw jack η_{gearbox} (without screw)

i	rpm	GSZ-2	Z-5	Z-10	Z-25	Z-35	Z-50	Z-100	Z-150	Z-250	Z-350	Z-500	Z-750	Z-1000
N	3000	0.87	0.81	0.83	0.87	-	-	-	-	-	-	-	-	-
N	1500	0.87	0.82	0.84	0.87	0.87	0.87	0.88	0.89	0.91	-	-	-	-
N	1000	0.86	0.82	0.82	0.86	0.87	0.86	0.87	0.89	0.90	0.91	0.92	0.88	0.90
N	750	0.86	0.82	0.84	0.85	0.86	0.85	0.87	0.88	0.90	0.91	0.92	0.88	0.90
N	500	0.85	0.82	0.84	0.83	0.85	0.84	0.85	0.87	0.89	0.90	0.92	0.87	0.89
N	100	0.74	0.77	0.79	0.78	0.78	0.78	0.78	0.80	0.83	0.86	0.87	0.81	0.84
L	3000	0.78	0.74	0.78	0.76	-	-	-	-	-	-	-	-	-
L	1500	0.77	0.70	0.74	0.72	0.64	0.66	0.67	0.67	0.78	-	-	-	-
L	1000	0.75	0.67	0.72	0.70	0.64	0.66	0.65	0.66	0.77	0.78	0.76	0.67	0.76
L	750	0.74	0.65	0.70	0.68	0.64	0.66	0.65	0.65	0.76	0.78	0.75	0.66	0.76
L	500	0.71	0.62	0.67	0.65	0.63	0.65	0.65	0.63	0.75	0.77	0.73	0.65	0.75
L	100	0.54	0.53	0.59	0.54	0.52	0.55	0.57	0.53	0.65	0.67	0.61	0.58	0.66

Efficiencies of the screws η_{screw}

calculated for coefficient of friction $\mu = 0.11$

Tr screw, single-pitch	16x4	18x4	20x4	30x6	40x7	50x8	55x9	60x9	80x16	100x16	120x16	140x20	160x20	Ball screw
Efficiency	0.453	0.420	0.391	0.391	0.357	0.335	0.340	0.320	0.391	0.335	0.293	0.308	0.278	0.9
Tr screw, double-pitch	16x8P4	18x8P4	20x8P4	30x12P6	40x14P7	50x16P8	55x18P9	60x18P9	80x32P16	100x32P16	120x32P16	140x40P20	160x40P20	
Efficiency	0.623	0.591	0.563	0.563	0.526	0.502	0.508	0.484	0.563	0.502	0.453	0.471	0.436	

Idling torques M_L of screw jacks [Nm] (without screw, at 20°C - significantly higher at low temperatures)

Z	2	5	10	25	35	50	100	150	250	350	500	750	1000
N	0.08	0.10	0.26	0.36	0.56	0.76	1.68	1.90	2.64	3.24	3.96	7.28	9.70
L	0.06	0.08	0.16	0.26	0.40	0.54	1.02	1.20	1.94	2.20	2.84	4.42	5.90

These are indicative values for calculation. Series production models may vary!



Maximum torques

Maximum input torque

In order to achieve optimum service life, do not exceed the values shown. If operating hours are lower, higher values may be achieved. Please contact us for advice.

max. input drive torques M_R [Nm]

i	rpm	GSZ-2	Z-5	Z-10	Z-25	Z-35	Z-50	Z-50/Tr50	Z-100	Z-150	Z-250	Z-350	Z-500	Z-750	Z-1000
N	3000	1.2	4.0	11.0	17.0	-	-	-	-	-	-	-	-	-	-
N	1500	1.4	4.7	13.5	18.0	19.8	31.5	31.5	53.4	75.1	152	-	-	-	-
N	1000	1.5	5.6	14.0	22.0	20.8	36.8	36.8	60.8	77.1	152	265	408	480	680
N	500	1.6	6.1	16.7	28.0	24.8	46.5	46.5	75.3	95.0	160	350	500	640	960
L	3000	0.5	1.4	5.7	8.5	-	-	-	-	-	-	-	-	-	-
L	1500	0.5	1.5	7.5	10.0	9	10.4	10.4	13.5	20.7	41.4	-	-	-	-
L	1000	0.5	1.8	8.7	11.0	9.7	14.9	14.9	15.4	23.7	47.4	100	170	210	450
L	500	0.6	2.2	10.7	14.0	11.1	19.2	19.2	18.9	29.4	63.5	112	220	240	580

The stated limit values are mechanically-based - thermal factors may be relevant depending on the duty cycle

Max. drive-through torque

Where several gearboxes are arranged in series the drive-through torque may be significantly greater than the maximum input drive torque. Only the torsional load on the shaft needs to be considered, not the load on the gear teeth.

max. worm shaft drive-through torque [Nm]

GSZ-2	Z-5	Z-10	Z-25	Z-35	Z-50	Z-50/Tr50	Z-100	Z-150	Z-250	Z-350	Z-500	Z-750	Z-1000
9	39	57	108	130	260	260	540	540	770	1800	1940	4570	4570



Drive torque for screw jacks - approximate calculation

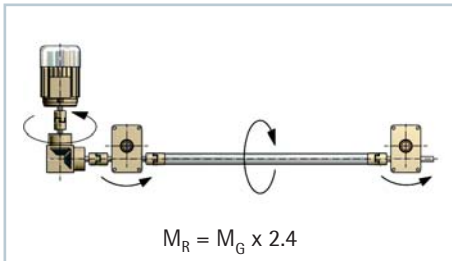

Calculation

The drive torque required for a lifting system is the sum of the torques for the individual screw jacks and increases due to frictional losses on transfer components such as couplings, connecting shafts, bevel gearboxes etc.

To simplify the calculation, the following factors are used to determine the drive torque for the most common system layouts.

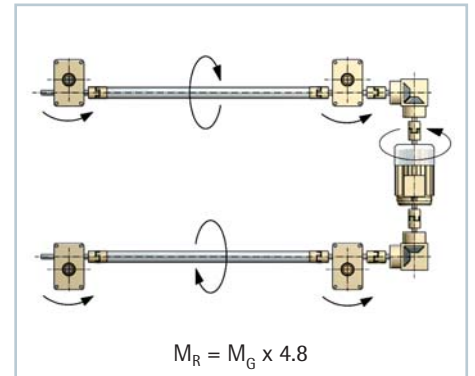
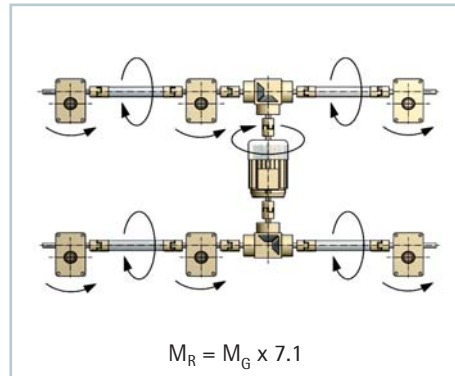
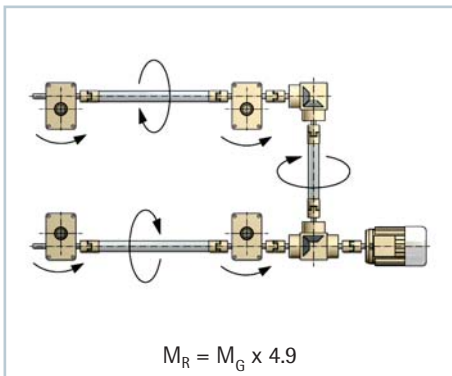
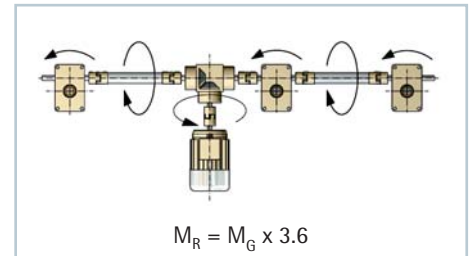
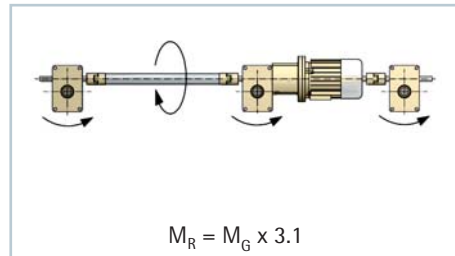
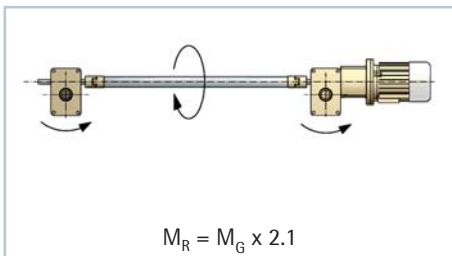

M_R - Overall drive torque for the entire system.

M_G - Drive torque for an single gearbox

M_A - Starting torque max. $1.5 \times M_R$

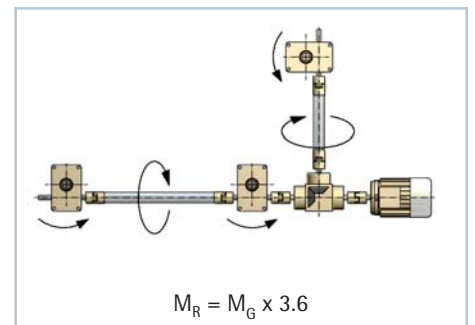
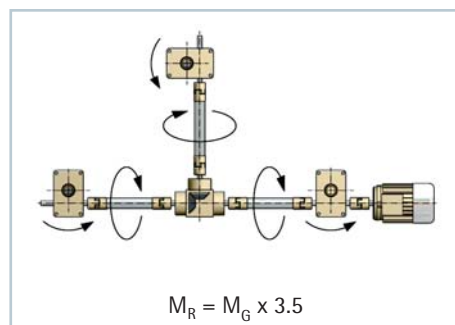

Example (example from page 162, 12 kN per gearbox)

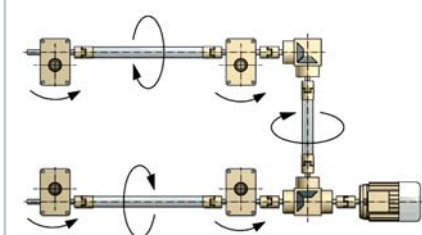

$$M_R = M_G \times 4.9 = 5.97 \text{ Nm} \times 4.9 = 29.25 \text{ Nm}$$

→ x safety factor 1.4 = 40.95 Nm

CAUTION:

We recommend multiplying the calculated value by a safety factor of 1.3 to 1.5 (up to 2 for small systems and for low speeds). The values stated assume equal distribution of the load across all gearboxes!

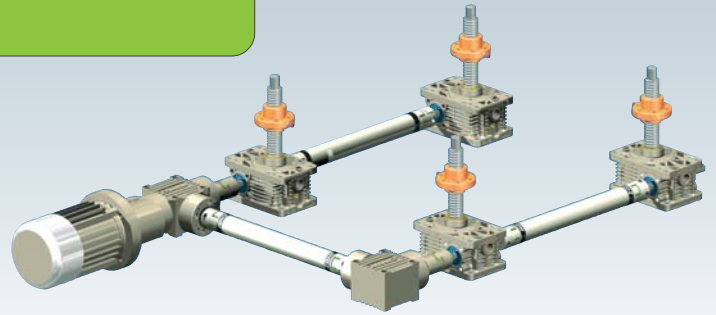

Drive torque for screw jacks – precise calculation

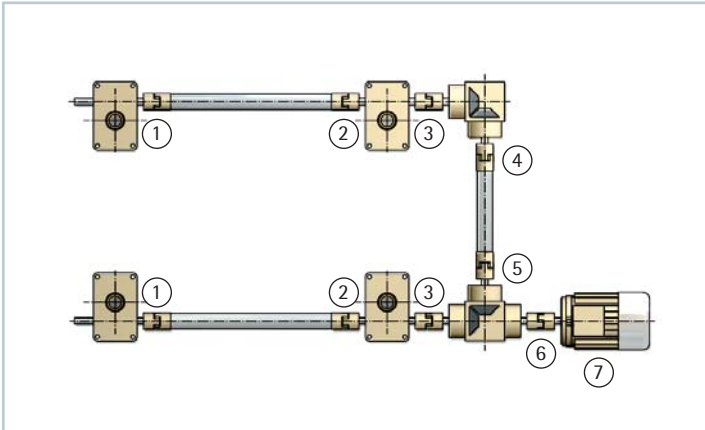

The following calculation example takes account of the efficiency of the connecting shafts (η 0.95) and bevel gearboxes (η 0.9).

Formula for the gearbox::

$$\text{Drive torque: } M_G = \frac{F \text{ [kN]} \cdot P \text{ [mm]}}{2 \cdot \pi \cdot \eta_{\text{gearbox}} \cdot \eta_{\text{screw}} \cdot i} + M_L \text{ [Nm]}$$

Efficiencies:

Connecting shafts:	η 0.95
Bevel gearbox:	η 0.90

Example:

$$1) \quad M_G = \frac{12 \text{ kN} \cdot 6 \text{ mm}}{2 \cdot \pi \cdot 0.87 \cdot 0.391 \cdot 6} + 0.36 \text{ Nm} = 5.97 \text{ Nm}$$

$$2) \quad \frac{5.97 \text{ Nm}}{0.95} = 6.28 \text{ Nm}$$

(efficiency of the connecting shaft)

$$3) \quad 5.97 \text{ Nm} + 6.28 \text{ Nm} = 12.25 \text{ Nm}$$

$$4) \quad \frac{12.25 \text{ Nm}}{0.9} = 13.61 \text{ Nm}$$

(efficiency of the bevel gearbox)

$$5) \quad \frac{13.61 \text{ Nm}}{0.95} = 14.33 \text{ Nm}$$

$$6) \quad 12.25 \text{ Nm} + 14.33 \text{ Nm}/0.9 = 29.53 \text{ Nm}$$

$$7) \quad 29.53 \text{ Nm} \cdot 1.4 = 41.34 \text{ Nm}$$

We recommend multiplying the calculated value by a safety factor of 1.3 to 1.5 (up to 2 for small systems and for low speeds).



Z-25-SN

$F = 12 \text{ kN}$ (dynamic lift load per gearbox)

$$\eta_{\text{gearbox}} = 0.87 \quad \eta_{\text{screw}} = 0.391$$

$$P = 6 \quad i = 6$$

$$12.25 \text{ Nm} \cdot 1.5 = 18.38 \text{ Nm}$$

-> so KSZ-25-L is OK (see Section 5)

41.34 Nm -> we need a KSZ-50-L
(see Section 5)

Motor selection: 132M-P4-7.5 kW (50 Nm)
(for motors see Section 4)

maximum forces / torques

Loading definitions:

- F - Lifting load tensile and/or compressive
- F_S - Lateral loads on the screw
- v_H - Lifting speed of the screw
(or nut if the R version)
- F_A - Axial load on the input shaft
- F_R - Radial load on the input shaft
- M_R - Input torque
- n_R - Input speed

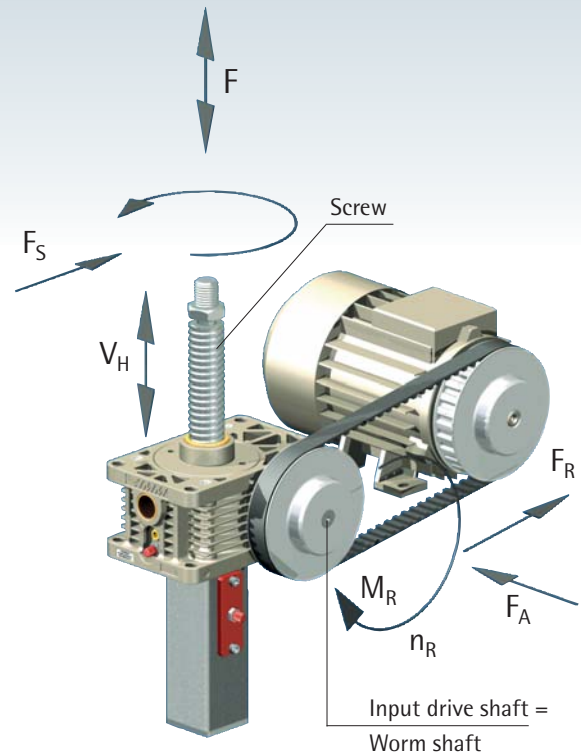

Lateral forces on the lifting screw

The maximum permissible lateral forces are shown in the table on the right. Lateral forces should generally be taken by linear guides. The guide bushing in the gearbox functions only as a secondary guide. The maximum lateral forces actually occurring must be less than the values shown in the table!

CAUTION: only applies to static forces.

maximum lateral force F_S [N] (only static)

extended screw length in mm

Z	100	200	300	400	500	600	700	800	900	1000	1200	1500	2000	2500	3000
5	360	160	100	70	55	45	38	32	28	25	20	18	12	-	-
10	600	280	180	130	100	80	70	60	50	47	40	30	20	15	-
25	900	470	300	240	180	150	130	110	100	90	70	60	45	35	30
35	1300	700	450	360	270	220	190	160	150	130	100	90	60	50	40
50	3000	2000	1300	900	700	600	500	420	380	330	280	230	160	130	100
100	5000	4000	3000	2300	1800	1500	1300	1100	950	850	700	600	400	350	250
150	5500	5000	3900	2800	2300	1800	1500	1300	1200	1000	850	750	500	400	350
250	9000	9000	6500	4900	3800	3000	2500	2200	2000	1900	1450	1250	900	760	660
350	15000	13000	12000	10000	8800	7000	6000	5500	4800	4300	3500	3000	2000	1600	1400
500	29000	29000	29000	29000	29000	24000	20000	17000	15000	14000	12000	9000	7000	5600	4900
750	34800	34800	34800	34800	34800	28800	24000	20400	18000	16800	14400	10800	8400	6720	5880
1000	46000	46000	39000	36000	32000	30000	25000	29000	25000	23500	20000	17000	12000	10000	8000

Radial load on the input shaft

Make sure that the radial forces arising where chain or belt drives are used do not exceed the values stated in the table alongside.

maximum radial load on the input shaft F_R [N]

	Z-5	Z-10	Z-25	Z-35	Z-50	Z-100	Z-150	Z-250	Z-350	Z-500	Z-750	Z-1000
F_R max.	110	190	260	260	420	650	670	1100	1400	2600	3000	3400



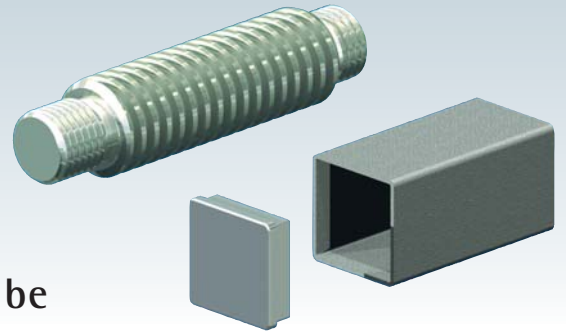

Length calculation – screw and protective tube

A quicker method

The tables on the following pages allow you to calculate the required screw length and protective tube extension length yourself. This lets you quickly calculate the fitting dimensions of your screw jack.

Principle

Depending on the version and accessories used the screw (and the protective tube on the S version) are extended. These dimensions are minimum requirements. For special fitting situations, please provide a drawing or contact our project technicians.

Stroke + basic length (+ various extensions for variants/accessories)

Example S:

Z-25-SN, stroke: 250 mm
 Bellows Z-25-FB-300 (ZD=70mm)
 Fixing flange BF (means the bellows do not require an fixing ring)
 Rotation protection VS
 Limit switch ES

Screw length Tr:

$$\begin{array}{rcccccc}
 250 & + & 180 & + & 44 & + & 45 & = & 519 \text{ mm} \\
 \text{Stroke} & & \text{Basic length} & & \text{Bellows} & & \text{Limit switch +} & & \text{Screw length} \\
 & & & & (70-26=44) & & \text{rotation protection} & & \\
 & & & & \text{Section 4} & & & &
 \end{array}$$

Protective tube length SRO:

$$\begin{array}{rcccccc}
 250 & + & 53 & + & 72 & = & 375 \\
 \text{Stroke} & & \text{Basic length} & & \text{Limit switch +} & & \text{Protective tube length} \\
 & & & & \text{Rotation protection} & &
 \end{array}$$

Example R:

Z-25-RN, stroke 250 mm
 Screw with end support (opposed bearing plate GLP)
 Bellows Z-25-FB-300 (ZD=70mm) above and underneath
 Duplex nut DM

Screw length Tr:

$$\begin{array}{rcccccc}
 250 & + & 139 & + & 60 & + & 55 & + & 50 & = & 554 \text{ mm} \\
 \text{Stroke} & & \text{Basic length} & & \text{Bellows gearbox side} & & \text{2nd bellows} & & \text{Duplex nut} & & \text{Screw length} \\
 & & & & (70-10=60) & & (70-15=55) & & & &
 \end{array}$$

See Section 4 for the length calculation for connecting shafts.

Abbreviations:

Tr	Trapezoidal screw	KGT	Ball screw
AS	Escape protection	KAR	Pivot bearing plate
BF	Fixing flange	KGK	Rod end
ES	Limit switch	SLK	Pivot bearing end
FBR	Bellows fixing ring	ZD	Compressed length
GK	Forked end		

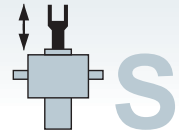
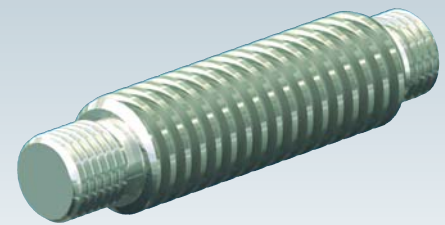

Length calculation – screw, translating version S

(The length calculation is identical for Z and GSZ)

GSZ-2 to Z-150:		GSZ-2	Z-5	Z-10	Z-25	Z-35	Z-50	Z-50/Tr50	Z-100	Z-150
Tr basic length	Tr	118	139	161	180	219	240	263	338	342
KGT basic length	KGT	-	16x05 203	25x05 240	32x05 272	-	40x05 324	-	50x10 ⁽³⁾ 420	63x10 ⁽⁵⁾ 432
		-	16x10 224	25x10 260	32x10 282	-	40x10 324	-	50x20 ⁽³⁾ 460	63x20 ⁽⁶⁾ 506
		-	-	25x25 330	32x20 312	-	40x20 354	-	50x10 ⁽⁴⁾ 456	63x10 ⁽⁷⁾ 460
		-	-	25x50 460	32x40 382	-	40x40 414	-	50x20 ⁽⁴⁾ 496	63x20 ⁽⁷⁾ 500
		-	-	-	-	-	-	-	50x40 ⁽⁴⁾ 576	63x40 ⁽⁷⁾ 580
		-	-	-	-	-	-	-	-	63x60 ⁽⁷⁾ 660
Tr basic length with safety nut	Tr	-	-	219	239	280	305	-	411	423
Escape/rotation protection AS/VS	Tr/KGT	15	15	20	20	30	30	30	30	30
Limit switch ES ⁽²⁾	Tr	43	43	45	45	59	55	55	45	45
ES ⁽²⁾ and pivot bearing plate KAR	Tr	65	64	65	69	85	80	80	90	95
Limit switch ES ⁽²⁾	KGT	-	16x05 38	25x05 40	32x05 40	-	40x05 50	-	50x10 45	63x10 45
		-	16x10 28	25x10 30	32x10 35	-	40x10 50	-	50x20 30	63x20 30
		-	-	25x25 20	32x20 20	-	40x20 35	-	50x40 30	63x40 30
		-	-	25x50 20	32x40 20	-	40x40 30	-	-	63x60 30
ES ⁽²⁾ and pivot bearing plate KAR	KGT	-	16x05 59	25x05 60	32x05 64	-	40x05 75	-	50x10 90	63x10 95
		-	16x10 49	25x10 50	32x10 59	-	40x10 75	-	50x20 70	63x20 75
		-	-	25x25 20	32x20 44	-	40x20 60	-	50x40 30	63x40 35
		-	-	25x50 20	32x40 20	-	40x40 30	-	-	63x60 30
Bellows with bellows fixing ring (GK/KGK) ⁽¹⁾	ZD-1	ZD-2	ZD+1	ZD+5	ZD+10	ZD+10	ZD+8	ZD-2	ZD-2	
Bellows without bellows fixing ring (BF/SLK) ⁽¹⁾	ZD-18	ZD-22	ZD-24	ZD-26	ZD-36	ZD-36	ZD-40	ZD-50	ZD-22	
Bellows and KAR with FBR (GK/KGK) ⁽¹⁾	ZD+32	ZD+31	ZD+28	ZD+46	ZD+63	ZD+63	ZD+81	ZD+60	ZD+68	
Bellows and KAR without FBR (BF/SLK) ⁽¹⁾	ZD+15	ZD+11	ZD+3	ZD+15	ZD+17	ZD+17	ZD+33	ZD+12	ZD+48	

Z-250 to Z-1000:		Z-250	Z-350	Z-500	Z-750	Z-1000
Tr basic length	Tr	370	424	552	619	643
KGT basic length	KGT	80x10 561	100x20 663	125x25 823	140x25 976	160x25 1024
		80x20 601	100x40 743	125x40 883	140x40 1036	160x40 1084
		80x40 681	100x60 823	125x60 963	140x60 1116	160x60 1164
		80x60 761	100x80 943	125x80 1043	140x80 1196	160x80 1244
Tr basic length with safety nut		507	-	-	-	-
Escape/rotation protection AS/VS	Tr/KGT	30	35	40	40	40
Limit switch ES ⁽²⁾	Tr	43	46	40	48	48
Limit switch ES ⁽²⁾	KGT	80x10 43	100x20 35	125x25 40	140x25 40	160x25 40
		80x20 30	100x40 35	125x40 40	140x40 40	160x40 40
		80x40 30	100x60 35	125x60 40	140x60 40	160x60 40
		80x60 30	100x80 35	125x80 40	140x80 40	160x80 40
Bellows with bellows fixing ring (GK/KGK) ⁽¹⁾		ZD-2	ZD-2	ZD-22	ZD-22	ZD-22
Bellows without bellows fixing ring (BF/SLK) ⁽¹⁾		ZD-22	ZD-22	ZD-42	ZD-42	ZD-42

Safety distances are already included in the basic lengths!

(Tr screws: 10 mm up to Z-50, 20 mm for Z-100 to Z-500, 40 mm for Z-750 and Z-1000)

- The value will be added to or subtracted from the ZD dimension of the bellows depending on the sign and the result then added to the screw length. Applicable only to Tr single-pitch screws, not to double-pitch and KGT screws.
- Limit switches ES are always used in combination with rotation protection VS (VS is included in the extension).
- KGT 50: L6=82
- KGT 50: L6=118
- KGT 63: L6=90
- KGT 63: L6=124
- KGT 63: L6=118

Screw extension for spiral spring cover SF: Since the extension for spiral spring covers varies according to the fitting, this variant must be determined from a drawing. We would be pleased to prepare this drawing for you.

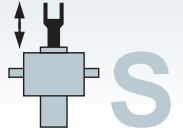
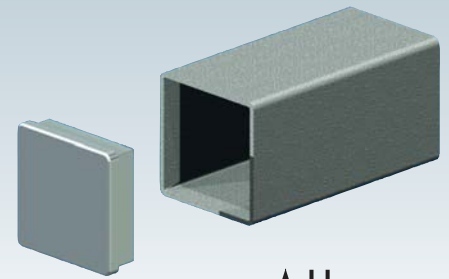

Length Calculation – protective tube SRO, translating version S

(The length calculation is identical for Z and GSZ)

GSZ-2 to Z-150:		GSZ-2	Z-5	Z-10	Z-25	Z-35	Z-50	Z-50/Tr50	Z-100	Z-150
Tr basic length ¹⁾	Tr	47	46	49	53	57	62	62	82	87
KGT basic length ¹⁾	KGT	–	16x05 56	25x05 59	32x05 63	–	40x05 72	–	50x10 82	63x10 87
		–	16x10 76	25x10 79	32x10 73	–	40x10 72	–	50x20 122	63x20 127
		–	–	25x25 149	32x20 103	–	40x20 102	–	50x40 202	63x40 207
		–	–	25x50 279	32x40 173	–	40x40 162	–	–	63x60 287
Escape/rotation protection AS/VS	Tr/KGT	15	15	20	20	30	30	30	30	30
Limit switch ES ³⁾	Tr	70	73	72	72	86	82	82	62	62
ES ³⁾ and pivot bearing plate KAR	Tr	92	94	92	96	112	107	107	107	112
Limit switch ES ³⁾	KGT	–	16x05 63	25x05 62	32x05 62	–	40x05 72	–	50x10 62	63x10 62
		–	16x10 43	25x10 52	32x10 52	–	40x10 72	–	50x20 30	63x20 30
		–	–	25x25 20	32x20 22	–	40x20 42	–	50x40 30	63x40 30
		–	–	25x50 20	32x40 20	–	40x40 30	–	–	63x60 30
ES ³⁾ and pivot bearing plate KAR	KGT	–	16x05 84	25x05 82	32x05 86	–	40x05 97	–	50x10 107	63x10 112
		–	16x10 64	25x10 72	32x10 76	–	40x10 97	–	50x20 70	63x20 75
		–	–	25x25 20	32x20 46	–	40x20 67	–	50x40 30	63x40 35
		–	–	25x50 20	32x40 20	–	40x40 30	–	–	63x60 30

Z-250 to Z-1000 ⁴⁾ :		Z-250	Z-350	Z-500	Z-750	Z-1000
Tr basic length ¹⁾	Tr	92	107	157	157	157
KGT basic length ¹⁾	KGT	80x10 92	100x20 147	125x25 177	140x25 177	160x25 177
		80x20 132	100x40 227	125x40 237	140x40 237	160x40 237
		80x40 212	100x60 307	125x60 317	140x60 317	160x60 317
		80x60 292	100x80 387	125x80 397	140x80 397	160x80 397
Escape/rotation protection AS/VS	Tr/KGT	30	35	40	40	40
Limit switch ES ³⁾	Tr	58	59	40	48	48
Limit switch ES ³⁾	KGT	80x10 58	100x20 35	125x25 40	140x25 40	160x25 40
		80x20 30	100x40 35	125x40 40	140x40 40	160x40 40
		80x40 30	100x60 35	125x60 40	140x60 40	160x60 40
		80x60 30	100x80 35	125x80 40	140x80 40	160x80 40

CAUTION: minimum stroke with limit switch ES²⁾:

GSZ-2 to Z-150:		GSZ-2	Z-5	Z-10	Z-25	Z-35	Z-50	Z-50/Tr50	Z-100	Z-150
minimum stroke with limit switch ES		53	50	51	51	41	42	42	42	42
minimum stroke with ES and lubrication strip SL		123	120	121	121	111	112	112	112	112

Z-250 to Z-1000:		Z-250	Z-350	Z-500	Z-750	Z-1000
minimum stroke with limit switch ES		47	42	46	46	46
minimum stroke with ES and lubrication strip SL		117	112	116	116	116

- 1) Basic length of the protective tube without a cap.
The cap height is 5 mm.
- 2) If a shorter stroke than specified is required, the limit switches and lubrication strip may be fitted on different faces.
- 3) Limit switches ES are always used in combination with rotation protection VS (VS is included in the extension).
- 4) Z-250 - Z-1000:
 - only screw, or screw with escape protection AS (round protective tube)
 - with rotation protection VS or VS + limit switch ES (square protective tube)

Abbreviations:

Tr	Trapezoidal screw
KGT	Ball screw
KAR	Pivot bearing plate

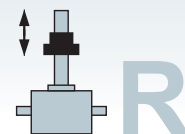
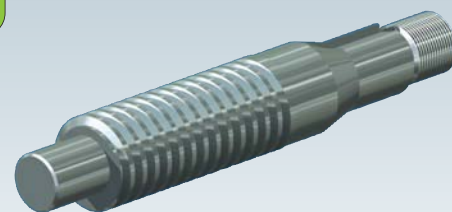

Length Calculation – screw, rotating version R

(The length calculation is identical for Z and GSZ)

GSZ-2 to Z-150:	GSZ-2		Z-5		Z-10		Z-25		Z-35		Z-50		Z-100		Z-150	
Tr basic length without journal	78		86		102		114		132		148		222		250	
Tr basic length with journal (= standard for opposed bearing plate GLP)	90		101		122		139		162		178		267		305	
Tr basic length increased screw with journal ¹⁾	93		106		127		144		177		193		277		325	
KGT basic length with journal ²⁾	16x05	100	16x05	111	25x05	132	32x05	149	40x05	172	40x05	188	50x10	267	63x10	305
	16x10	120	16x10	131	25x10	152	32x10	159	40x10	172	40x10	188	50x20	307	63x20	345
					25x25	222	32x20	189	40x20	202	40x20	218	50x40	387	63x40	425
					25x50	352	32x40	259	40x40	262	40x40	278	50x50	427	63x60	505
KGT basic length increased screw with journal ¹⁾²⁾			25x05	116	32x05	137	40x05	154	50x10	197	50x10	213	63x10	277	80x10	325
			25x10	136	32x10	147	40x10	154	50x20	237	50x20	253	63x20	317	80x20	365
			25x25	206	32x20	177	40x20	184	50x40	317	50x40	333	63x40	397	80x40	445
			25x50	336	32x40	247	40x40	244	50x50	357	50x50	373	63x60	477	80x60	525
KGT basic length without journal ²⁾	16x05	88	16x05	96	25x05	112	32x05	124	40x05	142	40x05	158	50x10	222	63x10	250
	16x10	108	16x10	116	25x10	132	32x10	134	40x10	142	40x10	158	50x20	262	63x20	290
					25x25	202	32x20	164	40x20	172	40x20	188	50x40	342	63x40	370
					25x50	332	32x40	234	40x40	232	40x40	248	50x50	382	63x60	450
KGT basic length increased screw without journal ¹⁾²⁾			25x05	96	32x05	112	40x05	124	50x10	152	50x10	168	63x10	222	80x10	250
			25x10	116	32x10	122	40x10	124	50x20	192	50x20	208	63x20	262	80x20	290
			25x25	186	32x20	152	40x20	154	50x40	272	50x40	288	63x40	342	80x40	370
			25x50	316	32x40	222	40x40	214	50x50	312	50x50	328	63x60	422	80x60	450
Flange nut FM	35		35		44		46		66		66		-		90	
Duplex nut DM	45		45		45		50		70		70		90		115	
Self-aligning nut PM	-		78		83		95		129		129		190		210	
Greaseless duplex nut FFDMM	-		53		53		59		85		85		-		-	
DM + safety nut SIFA	70		70		84		95		133		133		173		211	
PM + safety nut SIFA	-		123		128		158		212		212		298		330	
1. Bellows ³⁾	ZD-10		ZD-12		ZD-12		ZD-10		ZD-12		ZD-12		ZD-22		ZD-22	
2. Bellows ³⁾	ZD-10		ZD-10		ZD-14		ZD-15		ZD-15		ZD-15		ZD-20		ZD-30	
KAR screw face and 1st bellows ³⁾	ZD+23		ZD+21		ZD+15		ZD+31		-		-		-		-	
KGT flange nut KGF	add the respective nut length															

Z-250 to Z-1000:	Z-250		Z-350		Z-500		Z-750		Z-1000	
Tr basic length without journal	265		288		366		417		438	
Tr basic length with journal (= standard for opposed bearing plate GLP)	340		388		486		537		613	
Tr basic length increased screw with journal ¹⁾	365		408		486		592		-	
KGT basic length with journal ²⁾	80x10	340	100x20	428	125x25	506	140x25	557	160x25	633
	80x20	380	100x40	508	125x40	566	140x40	617	160x40	693
	80x40	460	100x60	588	125x60	646	140x60	697	160x60	773
	80x60	540	100x80	668	125x80	726	140x80	777	160x80	853
KGT basic length without journal ²⁾	80x10	265	100x20	328	125x25	386	140x25	437	160x25	458
	80x20	305	100x40	408	125x40	446	140x40	497	160x40	518
	80x40	385	100x60	488	125x60	526	140x60	577	160x60	598
	80x60	465	100x80	568	125x80	606	140x80	657	160x80	678
Duplex nut DM	140		160		180		220		320	
Self-aligning nut PM	224		275		-		-		-	
DM + safety nut SIFA	250		270		303		365		500	
PM + safety nut SIFA	369		455		-		-		-	
1. Bellows ³⁾	ZD-22		ZD-22		-		-		-	
2. Bellows ³⁾	ZD-40		ZD-60		-		-		-	
KGT flange nut KGF	add the respective nut length									

Safety distances are already included in the basic lengths (2x: 1x above and 1x underneath)!
(Tr screws: 10 mm up to Z-50, 20 mm for Z-100 to Z-500, 40 mm for Z-750 and Z-1000)

- When using a larger diameter screw, select the components for the next size gearbox (Z-10 increased screw has a screw Tr 30x6 which means component Z-25 - this is then the calculated screw extension for size 25).
- The basic length for KGT screws includes the safety clearance L3 shown on the gearbox dimension sheet. The nut length must then be added to this.
- The value will be added to or subtracted from the ZD (compression) dimension of the bellows depending on the sign and the result then added to the screw length. Applicable only to Tr single-pitch screws, not to double-pitch and ball screws.

Screw extension for spiral spring cover SF:
Since the extension for spiral spring covers varies according to the fitting, this variant must be determined from a drawing. We would be pleased to prepare this drawing for you.

Ordering code

Gearbox type	Size	Version	Drive ratio	Screw version	Screw Ø / pitch	Number of screw starts, material	Stroke	List of accessories
[]	[]	[]	[]	[]	[] - []	[] - []	H	[] - [] - [] - []
Z GSZ	2 5 10 25 35 50 100 150 250 350 500 750 1000	S Translating version R Rotating version	N Normal e.g. i = 4:1 L Low speed e.g. i = 16:1	Tr Trapezoidal screw (not stated = Tr) Tr/SIFA Tr with safety nut SIFA OP EL ELV ELD NO KGT Ball screw	Tr 1804 2004 ... KGT 1605 1610 ...	1 single-pitch (not stated = single-pitch) 2* double-pitch I INOX (stainless steel) LH* left-handed	Stroke H + stroke in mm	List of accessories (in any sequence) see Section 4

*is available but not ex stock.
Lead time on request

- i** For enquiries or orders you may optionally:
- either list the parts individually
 - or define the complete screw jack in an ordering code in the format specified here



Ordering example:

	Z	10	SN	Tr	2004	1	H	300	FB390	VS	BF
Gearbox, type											
Size											
Version S or R											
Drive ratio N or L											
Screw version											
Screw diameter, screw pitch											
Number of starts											
Stroke											
List of accessories (in any sequence)											

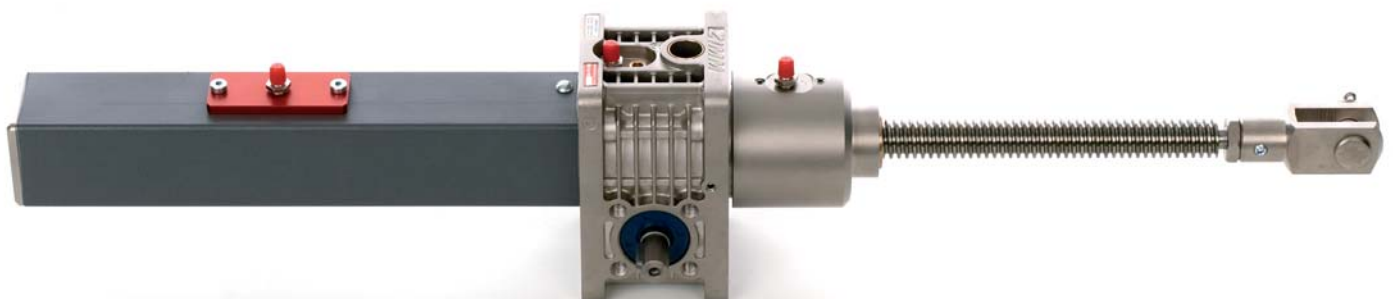

Innovative separate lubrication

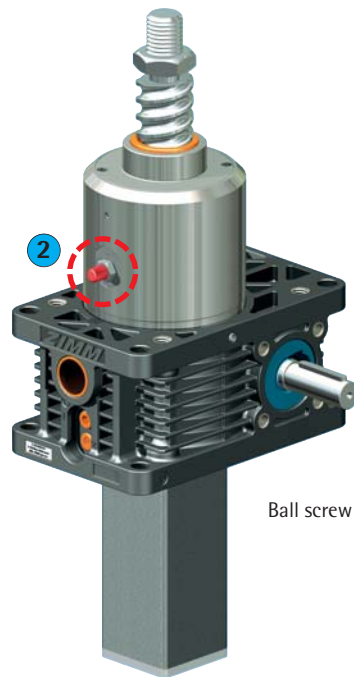
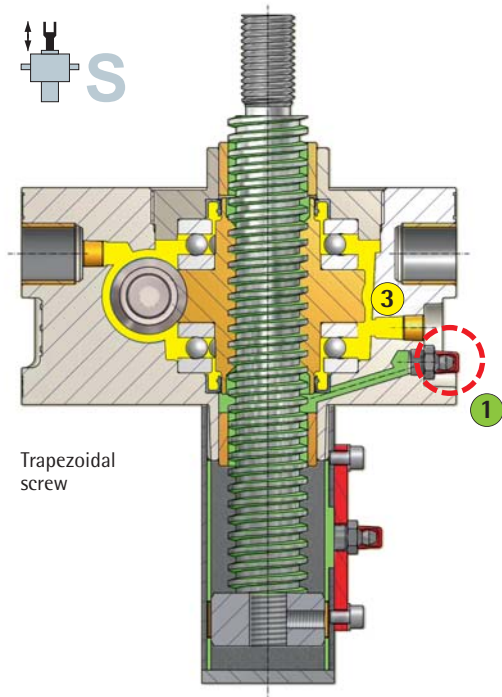

i The separate lubrication system is essential for high performance.

- 1** The **INNOVATION**: Screw lubrication **during operation** provides optimum grease distribution.
- 2** The same **INNOVATION** is also available for the ball screw version (KGT).

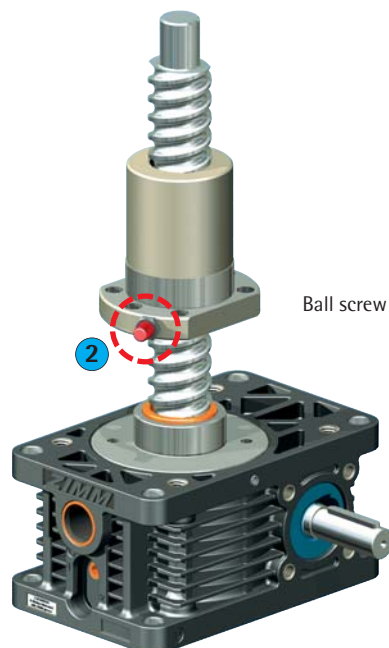
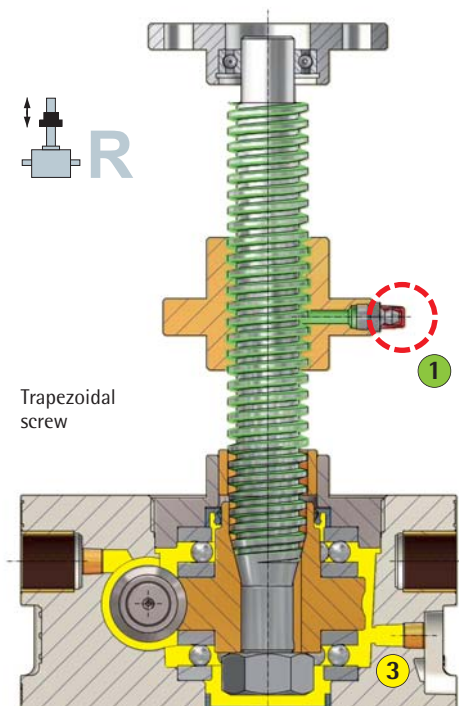

- 1** Screw lubrication **during operation** provides optimum grease distribution.
- 2** The same lubrication system is also available for the ball screw version (KGT).

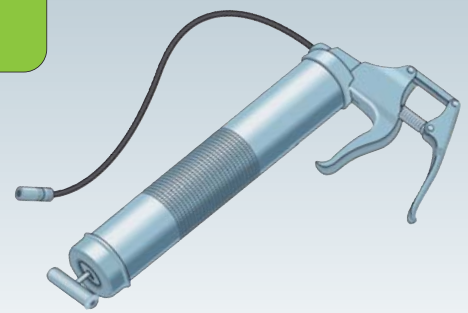

Screw lubrication

1 Trapezoidal screw

Inspect the trapezoidal screw regularly and regrease it depending on the operating cycle.

Use the grease that we recommend. These greases are ideally matched to the operating requirements of our screw jack systems.



2 Ball screw KGT

Lubricate the ball screw KGT every 300 hours of effective operation. For heavy-duty systems every 100 hours.

Grease quantity: Guidance value approx. 1 ml per cm screw diameter.



Gearbox lubrication

3 Gearbox lubrication

The gearbox is sealed and is filled with high-performance synthetic grease (gearboxes from Z-250 are oil-filled). The gearbox is lubricated for life in normal operation.

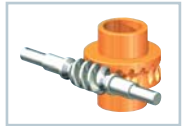

See Section 4 for the list of lubricants.

Cartridge 400 g



Lubricator
Z-LUB, ZIMM lubricator



Lubrication for short stroke applications

S version:

For short stroke applications (stroke < gearbox height), take particular care to ensure lubrication of the trapezoidal screw.

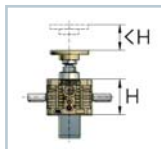

The simplest tactic is to specify the screw jack with a longer stroke than the gearbox height, and periodically perform a lubrication stroke. Otherwise, contact our Engineering Department for a suitable solution.

R version:

If stroke length < nut height, use a nut with lubrication capability (such as a duplex nut DM).



General

Special lubricants

For special applications and for the earlier MSZ gearboxes we can offer suitable lubricants in each case.

These include amongst others:

- High-temperature grease
- Low-temperature grease
- Food grade grease
- Clean room grease, etc.

Other greases, contamination

Using multipurpose greases and other greases can significantly impair operation and shorten the service life.

If the screw becomes dirty, clean and regrease it.

Long-life systems

The grease used in long-life systems (such as working platforms and theatre stages) loses its lubricating properties after about 5 years.

Dust and dirt penetration intensify this effect. We recommend complete cleaning and regreasing after 5 years.

If mineral greases are used, this may be necessary after only 2-3 years.

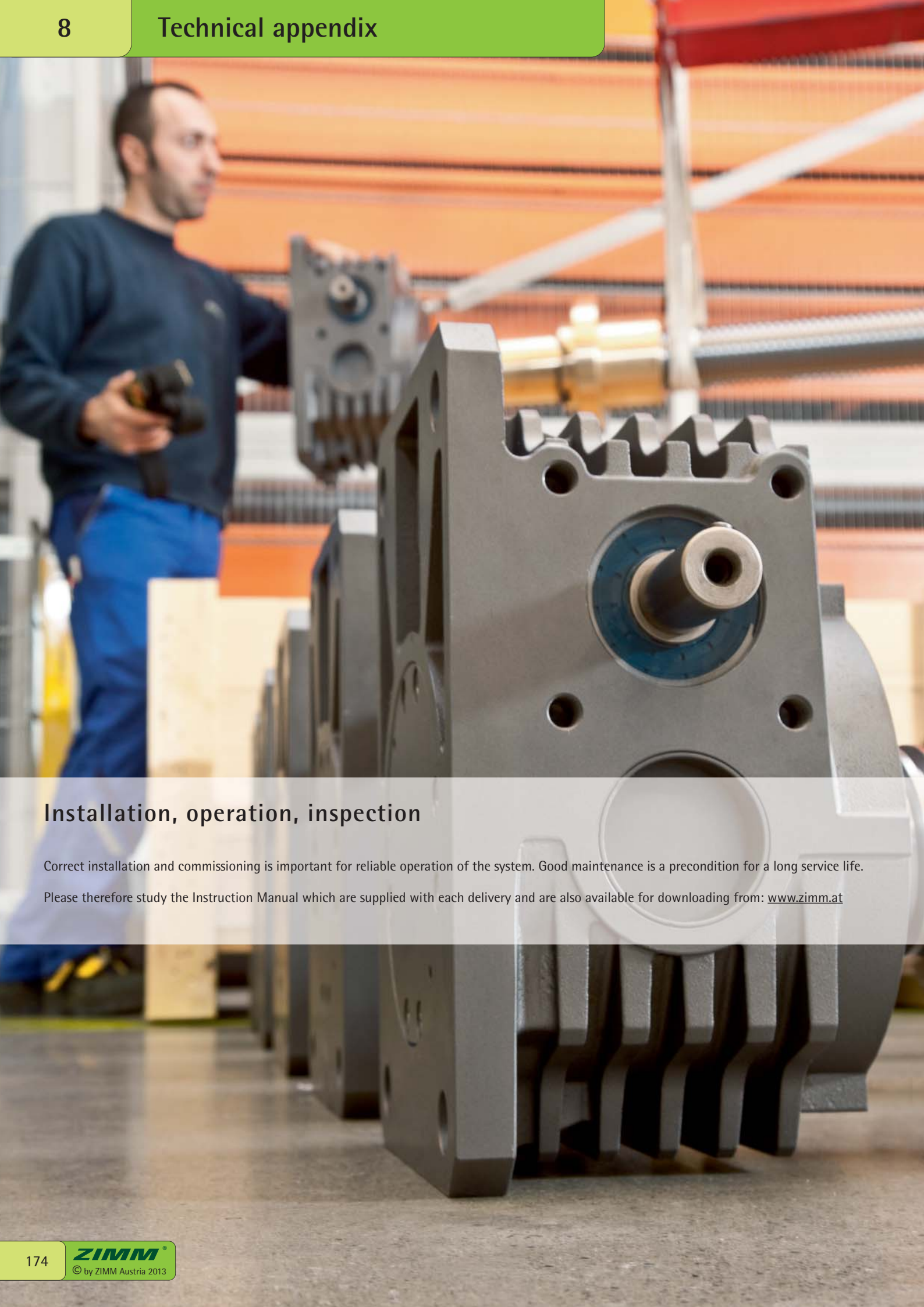

Installation, operation, inspection

Correct installation and commissioning is important for reliable operation of the system. Good maintenance is a precondition for a long service life.

Please therefore study the Instruction Manual which are supplied with each delivery and are also available for downloading from: www.zimm.at



Operational reliability and safety

Operational reliability and safety
Operational reliability and safety are just as important for industrial systems as for theatre stages and other systems.



Design and specification

During the design and specification phase, pay special attention to the load capacity of the drives and accessories in their proposed installation situation. Plan your system with appropriate safety for attachment, movement and transport elements.

Please note the design advice given in Section 8.

Where the system is safety-relevant, fit a safety nut SIFA. If the nut thread is stripped due to wear, the SIFA takes the load. An electronic control is available on request.



Installation

Correct and careful installation is essential for trouble-free and safe system operation. Please refer to our instruction manual included with each delivery. You can download these from the Internet at www.zimm.at



Inspection and maintenance

Regular inspection and maintenance are necessary to maintain reliability.



Check the following during the regular inspections:

Visual condition, attachments and connections, wear on the trapezoidal thread and the level of lubrication. Comply with our lubrication instructions and use only the lubricants we recommend. Please consider our automatic lubricator Z-LUB.

Spare parts

To protect against loss of production caused by high duty cycles or high loads, we recommend keeping a set of screw jack spare parts (including screws, accessories and with assembly drawings) at your location or at your customer's location. A screw jack can most economically be repaired by a complete exchange.

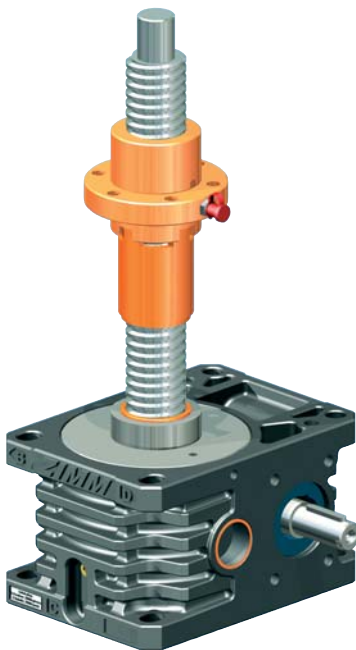

Screw jack with safety nut SIFA



ZIMM Instruction Manual in other languages and for special products are available on request or by downloading from www.zimm.at

Temperature

The ambient temperature is very important for system operation.

Always inform us about ambient temperature and conditions, especially if these deviate from the usual 20°C to 25°C.

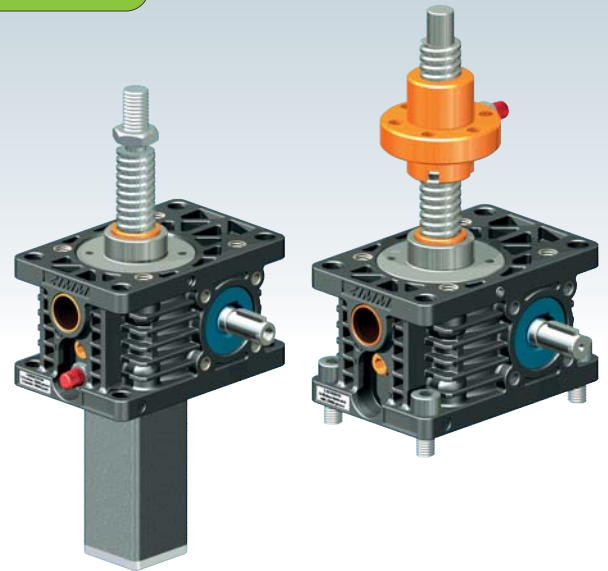

Normal temperature (-20°C to +60°C)

A normal temperature range is up to about 60°C gearbox operating temperature. The highest temperature rise is at the shaft seal ring and on the trapezoidal screw. Various tests have shown that the temperature rise of a Tr screw is twice that of the gearbox housing.



Example:

At an ambient temperature of 20°C, the housing reached about 60°C (rise of 40°C) and the Tr screw about 100°C (rise of 80°C).

We recommend the temperature of Tr screws should not exceed 100°C when using standard gearboxes.

Low temperature (-20°C to -40°C):

Seals and most of our greases are specified in principle for temperatures down to -40°C. Experience has however shown that applications below -20°C are critical. The grease becomes very viscous and hard to move and it becomes difficult in particular to satisfy the breakaway torque.

Generally speaking, all components must be sized adequately for minus temperatures because the material strength is reduced (apart from aluminium).

We recommend low temperature grease for temperatures less than -20°C. Our standard gearboxes up to size Z-150 are filled as standard with a synthetic fluid grease that is already suitable down to -40°C.



High temperatures (+60°C to +160°C):

For ambient and operating temperatures (gearbox housing) higher than 60°C we recommend gearboxes with high-temperature grease and FPM seals. These can generally permit operating temperatures up to 160°C.

High temperatures (up to +200°C):

At temperatures up to 200°C we use FPM seals and a special grease.

We offer appropriate heat-resistant components for high temperature applications.

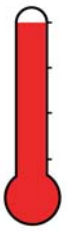
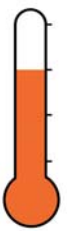

Temperature range of standard parts:

Standard screw jacks	-25°C to +80°C (-40°C to +100°C)
High temperature screw jacks	up to 160°C, or 200°C
Round bellows	-32°C to +70°C (max. +85°C)
Polygonal bellows	-15°C to +70°C (no exposure to direct sunlight)
Limit switch	-30°C to +85°C
Rotary pulse encoder DIG	-40°C to +80°C
Motors	above 40°C reduced power, e.g. factor 0.8 at 60°C
Connecting shafts VWZ+KUZ-KK	0°C to +70°C, reduced from -20°C to +100°C (max. +120°C)
Couplings KUZ	-20°C to +70°C, reduced from -40°C to +100°C
Bevel gearboxes	-10°C to +90°C
Ball screws KGT	-20°C to +80°C

For lower and higher temperatures, please request information on the component from us, with your checklist (Section 7).

Ambient and operating temperatures:

The ambient temperature is relevant for components such as limit switches or bellows. For gearboxes, the operating temperature is slightly or considerably higher than the ambient temperature, depending on the duty cycle.

Clean room

Sectors

Various fields such as semiconductor production, flat screen production, optical and laser technology, spacecraft production etc. demand high cleanliness, which means that clean room standards must be maintained.

Clean room

A clean room is a room where the concentration of particles in the air is controlled and satisfies defined cleanliness classes. It is important to keep the particle contamination caused by work materials, lubricants and drives to a minimum.



Your system

Use the checklist in Section 7 to enquire about the system you require and also specify the particular requirements for your application. We can then offer you a system to meet your requirements.

Food industry

Food industry sector

The foodstuffs sector operates at a very high level of automation. On the one hand this promotes a very high level of hygiene, on the other hand it permits intelligent and efficient systems for economic production

Resistant against corrosion

Our Z and GSZ series are corrosion-resistant and are therefore very suitable for most applications in the food industry. The GSZ gearbox with its smooth surfaces is particularly suitable.

The Z and GSZ series are not suitable for special applications where stainless steel is mandatory.

Screw jack systems

We supply gearboxes and systems with food grade grease to the food industry. Our food grade greases are FDA-approved. Use the checklist in Section 7 to enquire about the system you require and also specify the particular requirements for your application.



Resistant against corrosion

Corrosion-resistant as standard - no need for painting

All relevant components of the ZIMM - Z series and GSZ series are coated as standard with various single-layer and multi-layer systems resistant against corrosion. This eliminates the need for time-consuming and cost-intensive painting.

The colours black, anthracite and silver are visually neutral and fit in with any colour combination. The coating are specially matched to the various base materials and their functions. This ensures high-quality protection against corrosion for many application areas.



Screw jack application examples

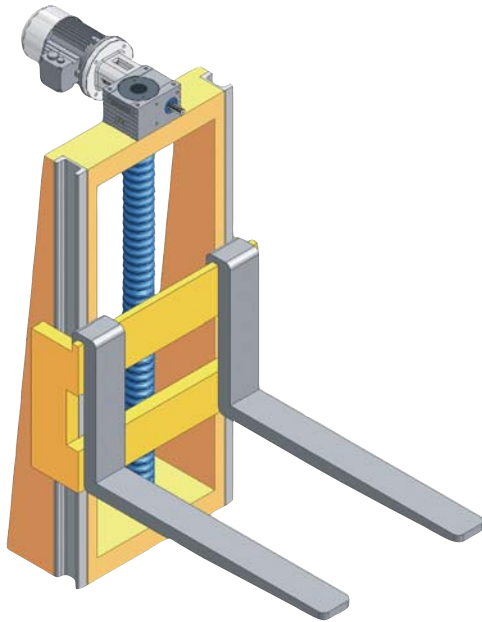

Translating lift for pallets

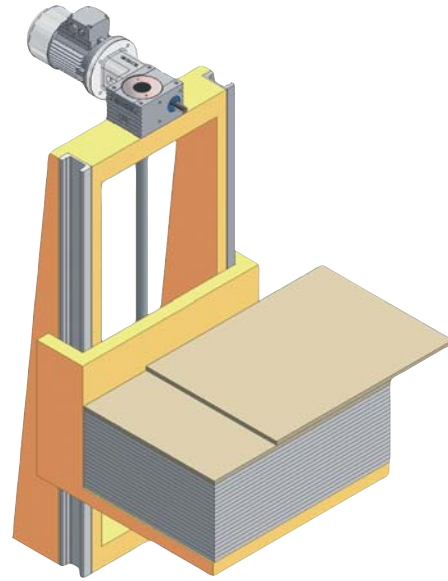

Unstacking unit for plate materials

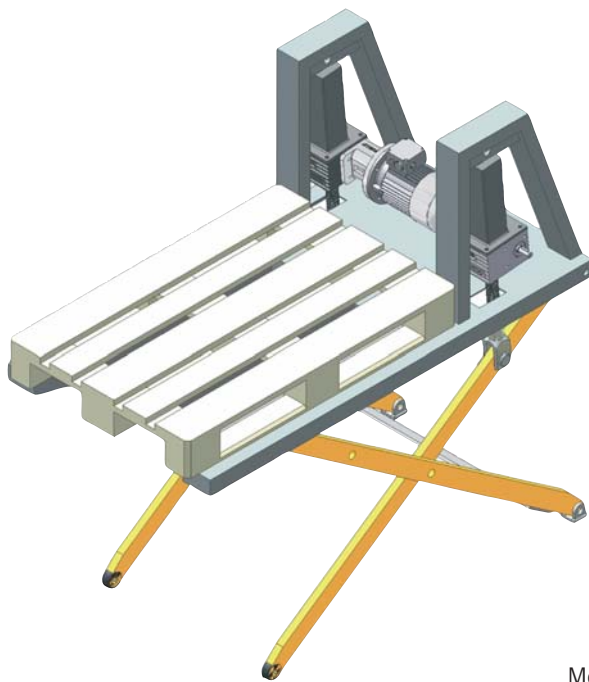

Mobile scissor table suitable for pallet truck transfer

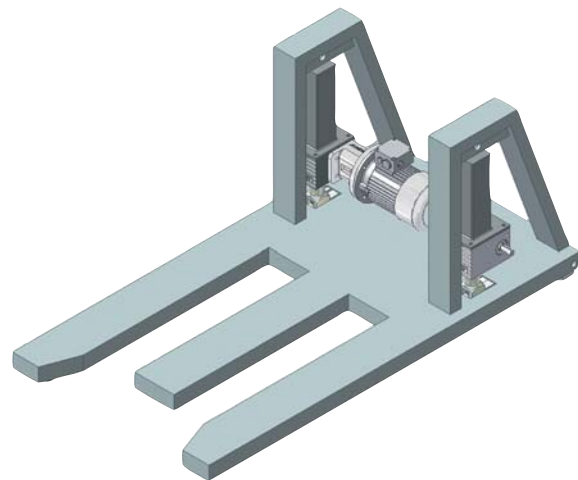

Screw jack application examples

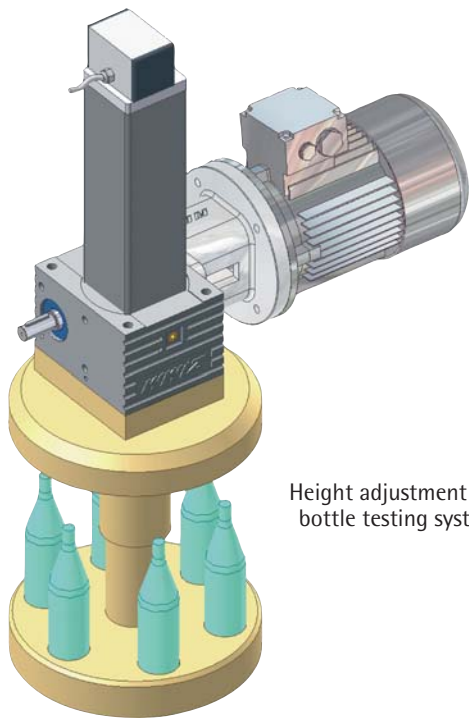

Height adjustment in a bottle testing system



Parabolic antenna $D = 3.3$ m, both axes – azimuth + elevation – each 50 kN, travel for each movement 0.02 – 0.05 mm; system installed in the open air on the coast

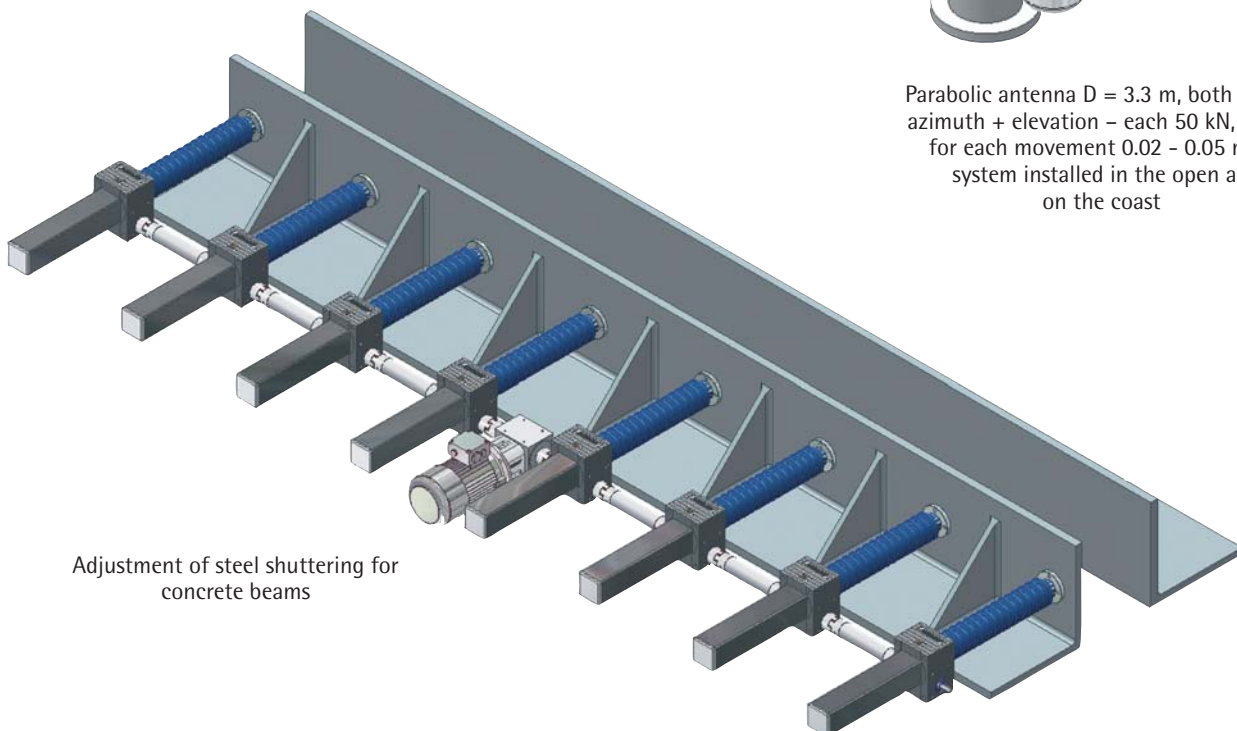

Adjustment of steel shuttering for concrete beams

Screw jack application examples

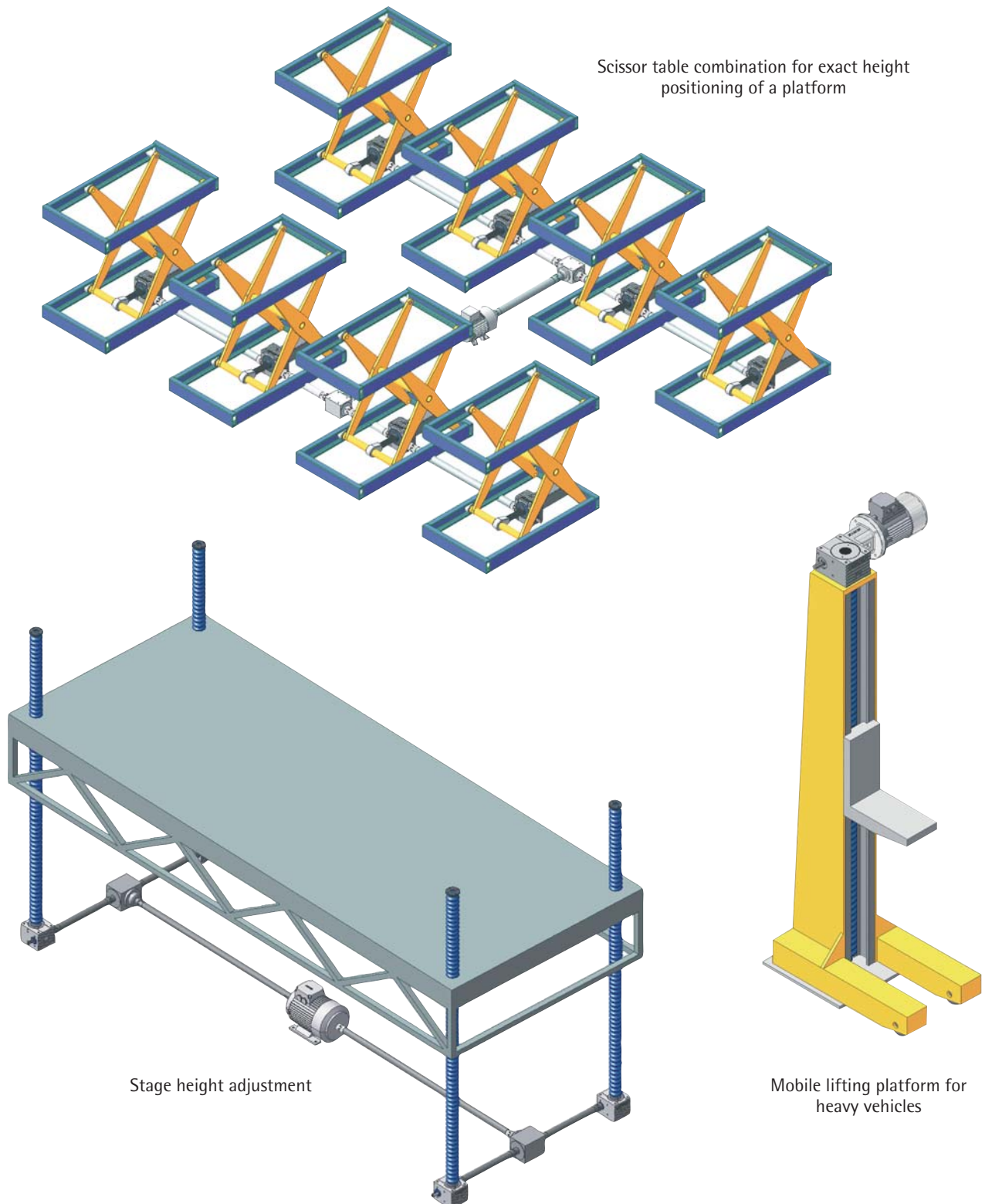

Screw jack application examples

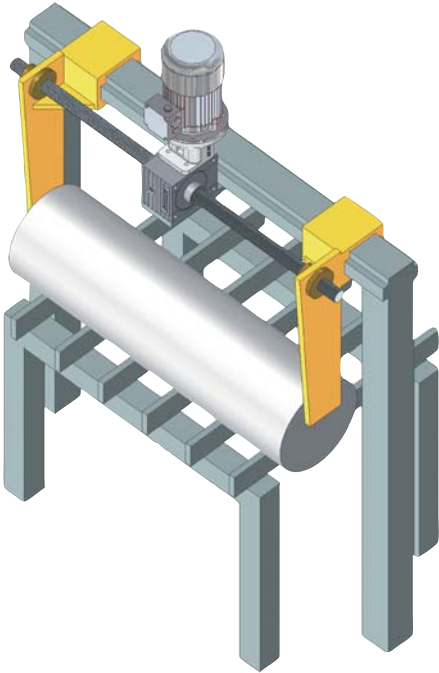

Centring mechanism using right
and left threaded screws

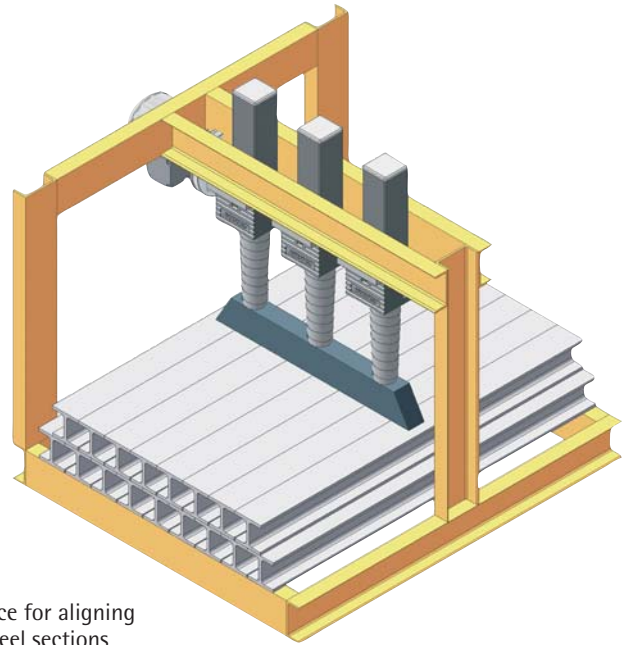

Device for aligning
steel sections

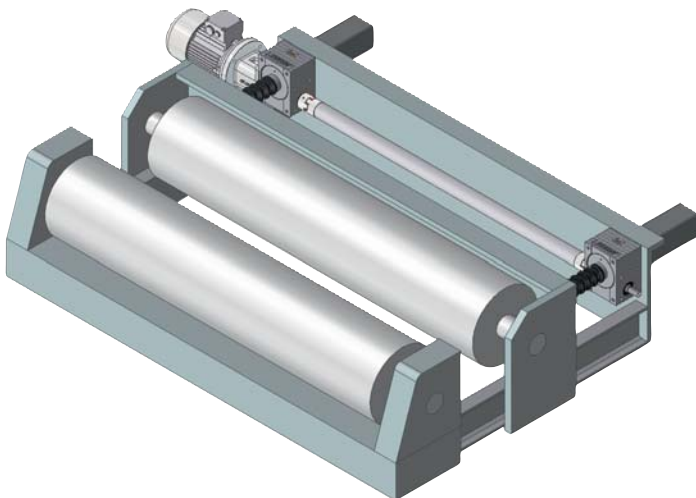

Adjustment system for bearings
in the textile industry

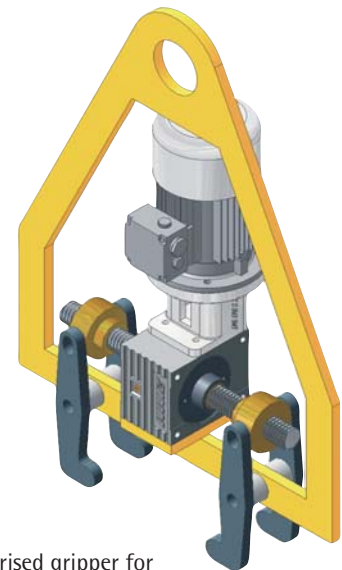

Motorised gripper for
steel sections

Screw jack application examples

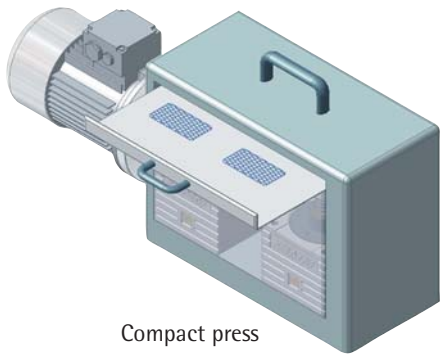

Compact press

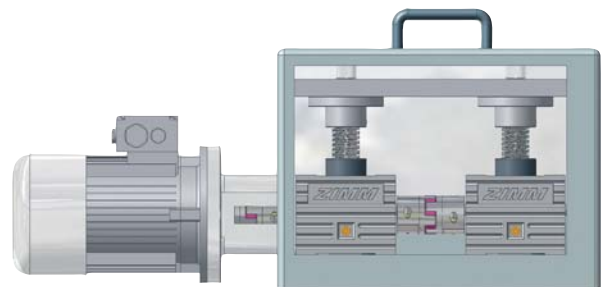

Compact press

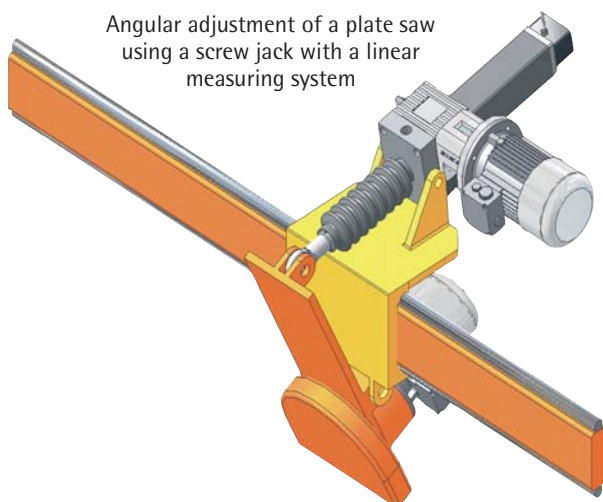
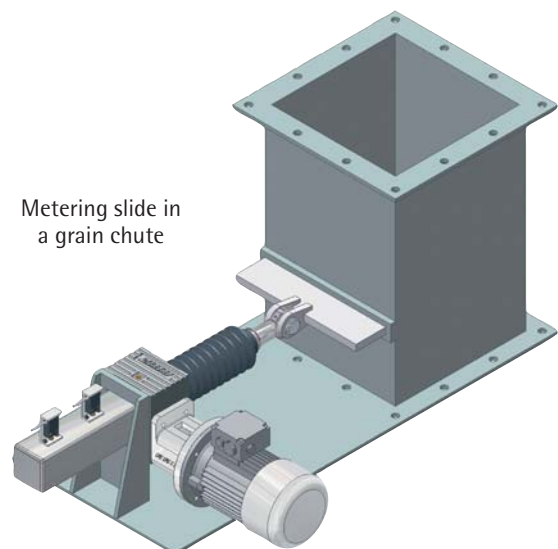
Angular adjustment of a plate saw
using a screw jack with a linear
measuring systemMetering slide in
a grain chute

Screw jack application examples

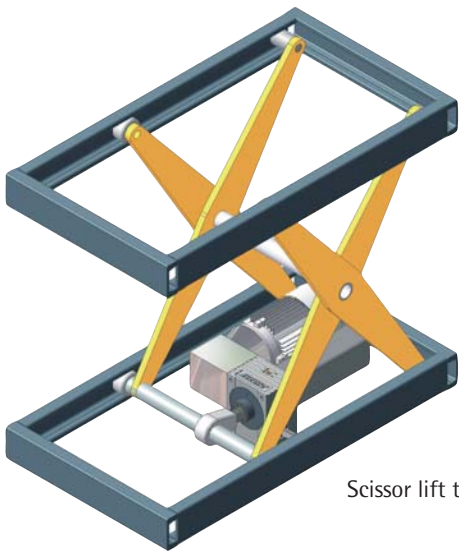

Scissor lift table

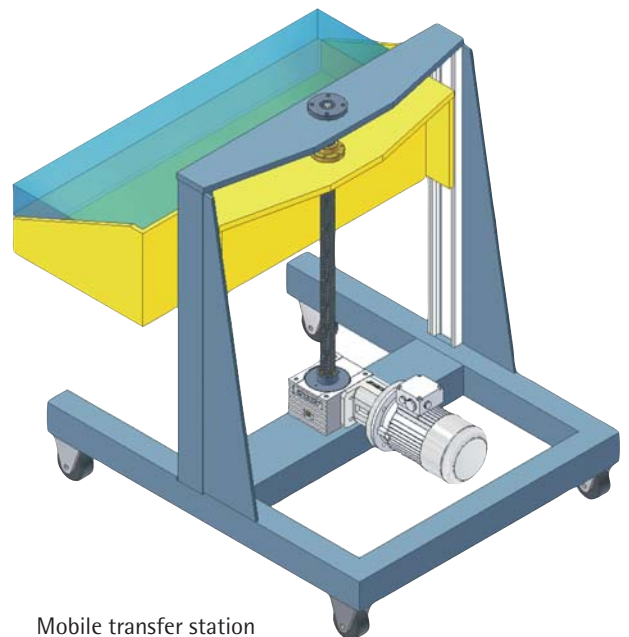

Mobile transfer station

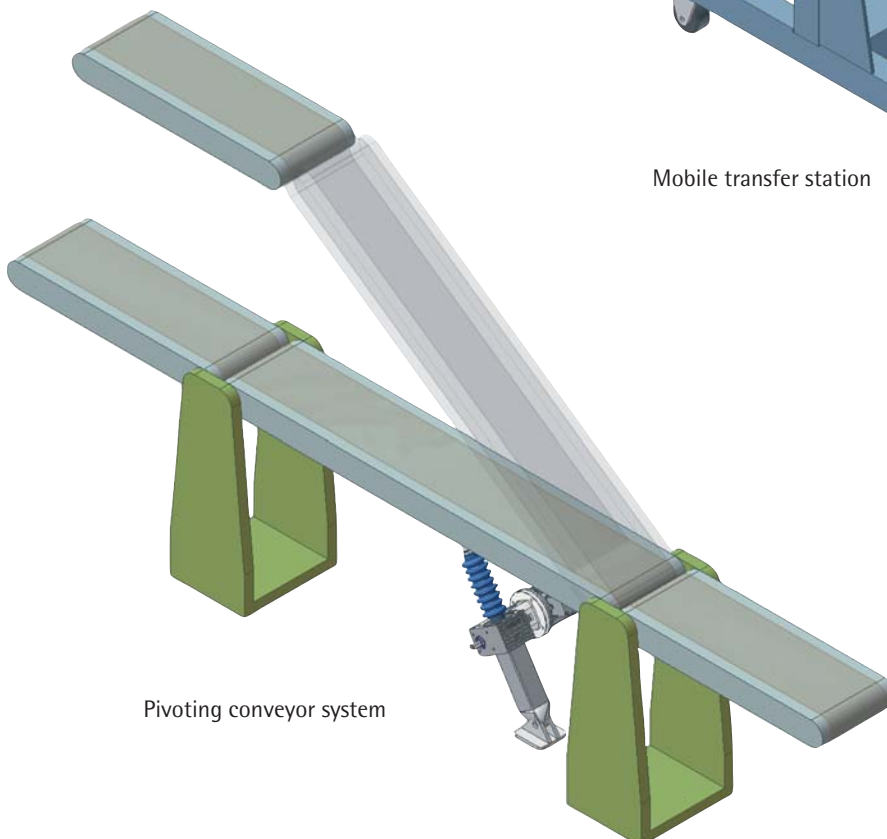

Pivoting conveyor system

Screw jack application examples

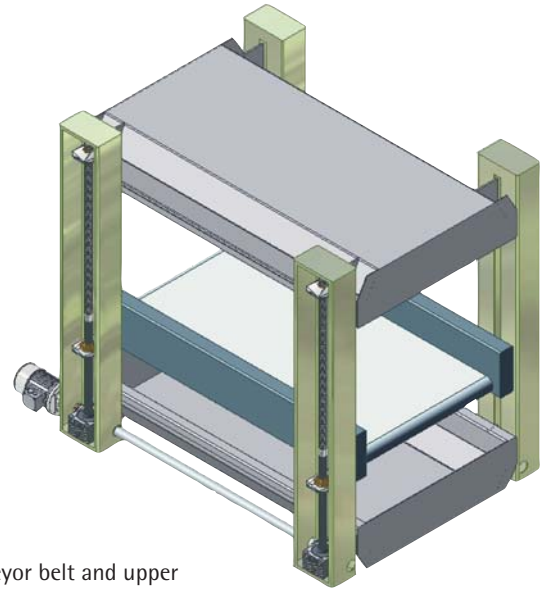
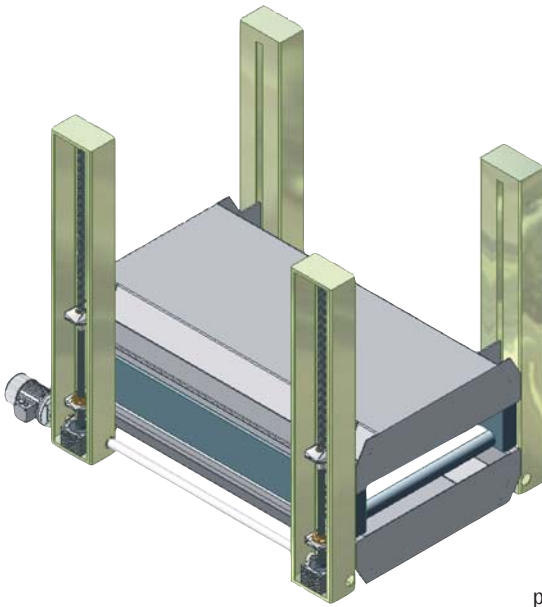

Cooling tunnel - the conveyor belt and upper part are raised to different heights using different screw pitches (single-pitch / double-pitch) for cleaning and maintenance purposes

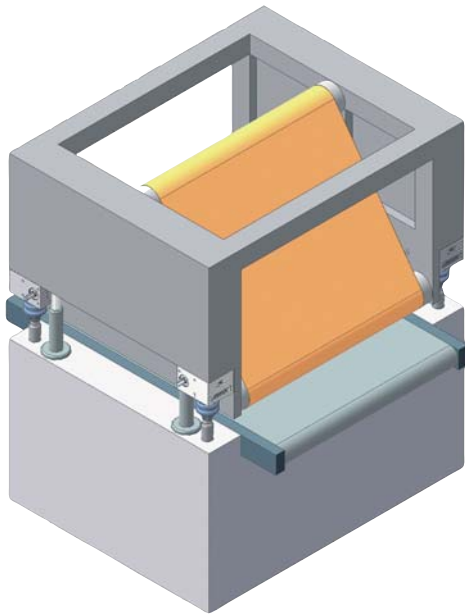

Wide belt grinding machine - precisely adjustable stop using 4 screw jacks

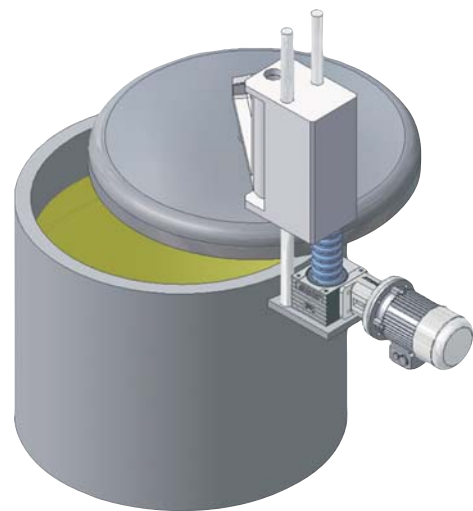

Opening and closing a container

Screw jack application examples

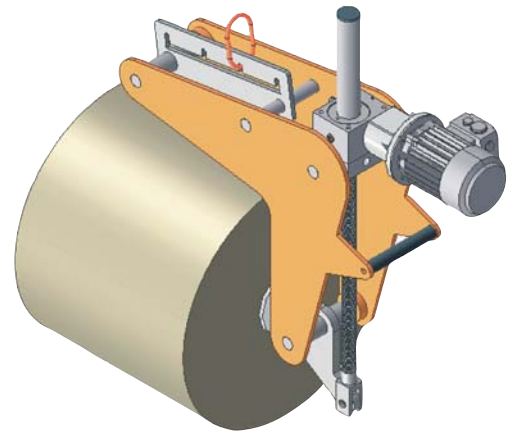
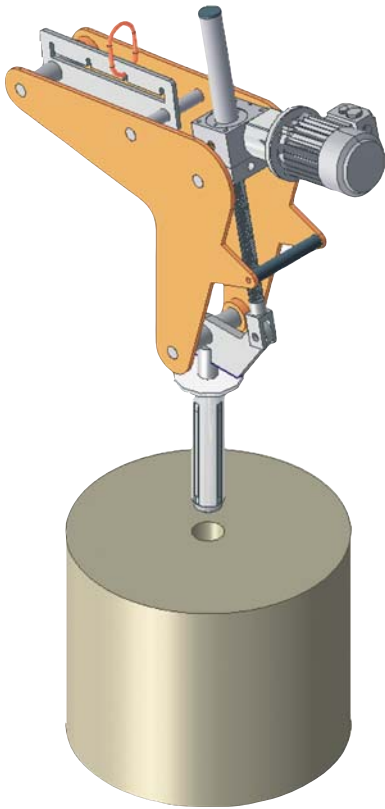

Film roll turning for horizontal and vertical loading and releasing

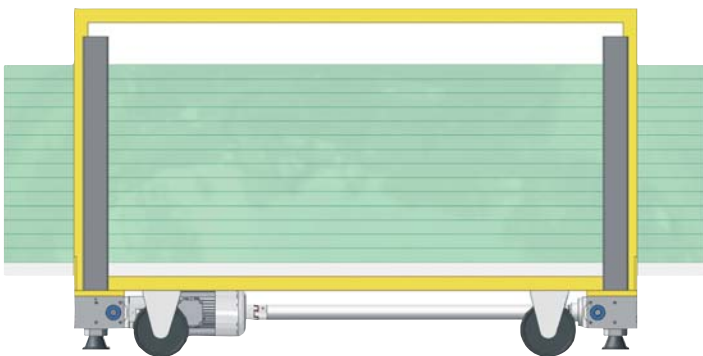

Panel transport trolley with precise height adjustment for a smooth transfer



Tradition and modernity all under one roof

We place great value on creative freedom and the courage to pursue new ideas. Our company location at Lustenau in the Vorarlberg Rhein valley reflects our entrepreneurial spirit and our philosophy.

At ZIMM we provide movement behind the scenes – as in a theatre.

For us, the focus is on the customer – we seek to provide solutions to his requirements with our innovative products and wide range of equipment – which has been our goal for more than 35 years.



left: Gunther Zimmermann (CEO)
right: Jürgen Zimmermann (Company founder)

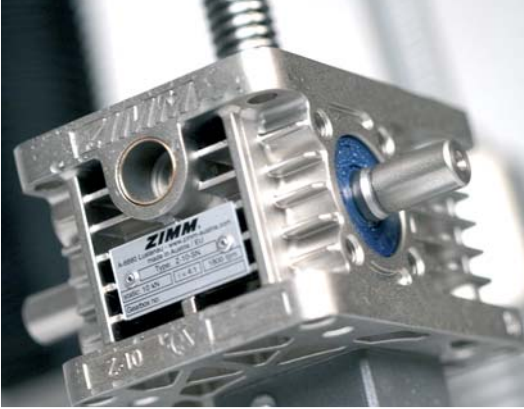

ZIMM – your partner for screw jack systems and transmission parts

- more than 35 years experience in drive technology
- present internationally in more than 40 countries in the world
- advice and support on site from factory-based and field service staff
- innovation by constant development of our product range with new and improved models
- very high product quality and a very good price-performance ratio
- short lead times thanks to intelligent logistics and stocking levels

Well-known companies trust ZIMM. You can rely on ZIMM – your capable partner for all aspects of drive technology.

Our experienced and qualified team offer full support at all times. We look forward to helping with your next project.

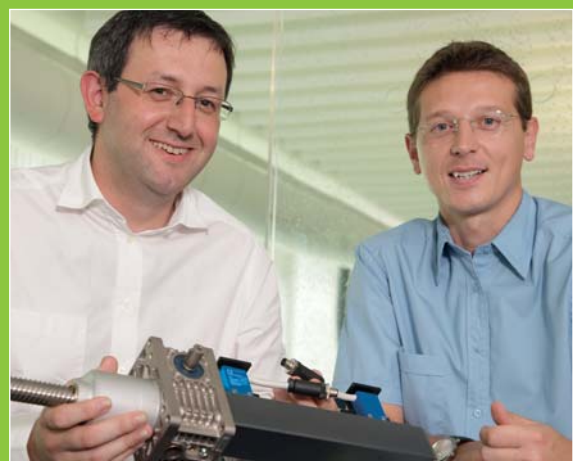

left: Peter Gridling, Manager, Screw Jack Systems
right: Martin Gfall, Manager, Transmission Parts

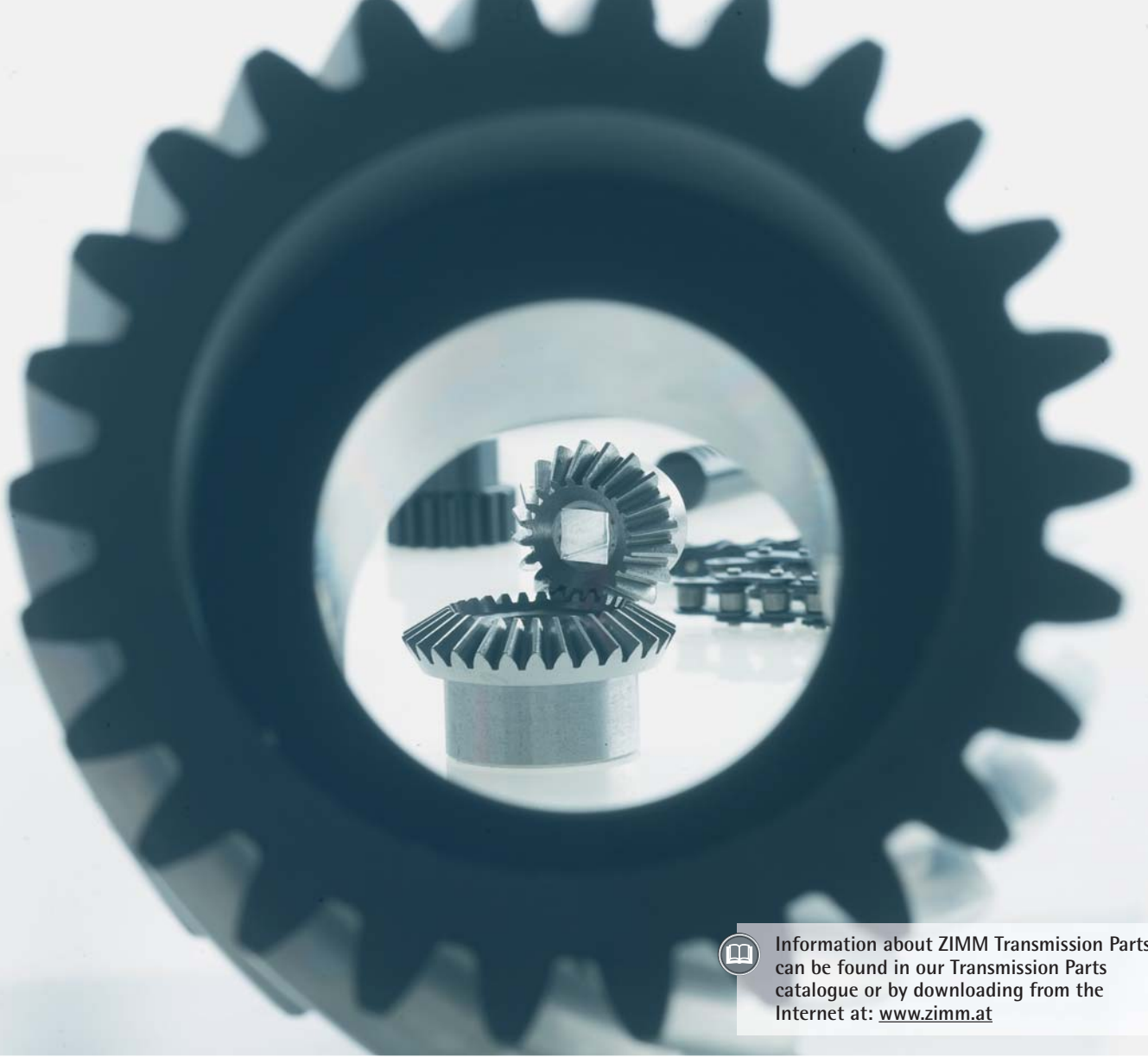

Information about ZIMM Transmission Parts can be found in our Transmission Parts catalogue or by downloading from the Internet at: www.zimm.at

ZIMM Transmission Parts

A wide selection of standard parts from the catalogue

- spur gears, internal ring gears, bevel gears,
- worm screws and worm wheels,
- splined shafts and hubs,
- toothed racks,
- toothed drive belts and pulleys,
- clamping bushes, clamping rings and clamping sets,
- trapezoidal screws and nuts,
- ball screws,
- couplings, connecting shafts,
- linear guides (profiles und rollers),
- precision guide shafts and linear ball bearings
- chains and chain sprockets

ROSTFREI Many components are also available in stainless steel on short lead times.

We will be happy to perform modifications to standard catalogue parts, such as drilling, slotting, turning and milling work.

We will also be happy to manufacture to your drawings.





ZIMM Actuators ZSA can be found in our Actuators catalogue or by downloading from the Internet at: www.zimm-solar.com

Photos: ALTEC and Andasun

ZIMM Actuators ZSA

Precisely following the sun – with tracking drives

The field of activity of our sister company ZIMM Solar GmbH is very large solar power arrays, such as those installed in Spain, Germany and the USA. So as to achieve the highest possible power generation, the photovoltaic cells track the sun at exactly the right angle from sunrise to sunset, using ZIMM Power Jack Systems "actuators". Precisely tracking the sun!

As well as photovoltaic installations, ZIMM actuators are also used for satellite tracking, wind turbines, cladding and shading systems, door drives and other industrial applications.

- Sturdy design accepts high tensile and compressive forces (available in 3 sizes)
- Quick and easy connection
- Resistant to wind and weather
- Low-maintenance for 20 years and more
- Alignment precision to 0.1 mm
- High reliability
- Flexible power supply arrangement (24 V DC, 230 V AC, 230/400 V AC, etc.)
- Integral rotary pulse encoders and limit switches
- Control options include CAN bus

Impressum | Copyright® by ZIMM Austria 2013

Owner, publisher and responsible for the content:

ZIMM Maschinenelemente GmbH + Co KG
Millennium Park 3, A-6890 Lustenau | Austria
Phone: 0043 (0)5577 806-0 | Fax: 0043 (0)5577 806-8
E-mail: info.zimm.at | www.zimm.at

ATU 35583506 | FN 15116 f, Feldkirch
ARA licence number 4334 | DVR 0510891

Partner with unlimited liability:
ZIMM Maschinenelemente GmbH, Lustenau
CEO: Gunther Zimmermann

Photos: Helmuth Heinz, Dietmar Wanko, Lars Wieser

Bank accounts**Austria:**

Raiffeisenlandesbank Bregenz
Account number: 11999 | Sort code 37000
IBAN AT 40 37000 00000011999 | BIC RVVGAT2B

Germany:

Raiffeisenlandesbank Kleinwalsertal AG
Account number: 123596 | Sort code 73361592

Switzerland:

UBS AG | account number 295-414585.01V | Clearing: 213
IBAN CH11 0029 5295 4145 8501 V | BIC UBSWCHZH80A

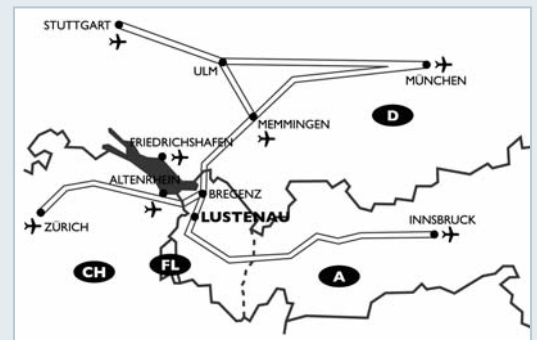
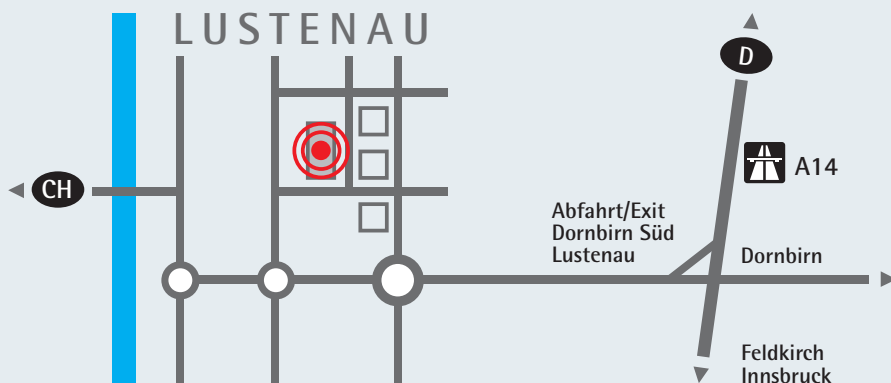
**Protection mark**

for restricting the use of documents to DIN 16016.

Except where indicated otherwise, reprinting, plagiarism, reprinting of extracts, copying of graphics and text are subject to the copyright® of ZIMM Maschinenelemente GmbH + Co KG, Millennium Park 3, 6890 Lustenau | Austria.

Storage, duplication, reproduction and distribution of the contents, in whole or in part, is permitted only with the written approval of ZIMM Maschinenelemente GmbH + Co KG, 6890 Lustenau. Breach of copyright creates liability to claims for damages. All rights are reserved in respect of granting of patents or industrial licences.

ISO quality management certificate

Certified according to the requirements of ISO 9001:2012
First certified: 17.12.1996 | Registration number: 00953/0

Patents

We have patents registered or pending for a range of functions and components.

Copyright and rights of use

All copyright and rights of use regarding information, artwork, photographs and drawings presented on our website and in our catalogues are reserved exclusively to us. Text and graphics are protected by copyright. Their use, duplication and re-use – especially where this involves distribution to third parties – requires our express permission in writing.

Exclusion of liability

Neither our website nor our catalogues ranks as commercial or legal advice. Such a commitment requires a specific enquiry and conclusion of a contract with us.

The contents of our catalogues and website are not binding and do not constitute an offer to conclude a contract. We accept no liability for the currency, accuracy or completeness of their contents. This applies in particular to contents of external websites accessed by links from our website. We are entitled to change the contents of our catalogues and website at any time. We accept no liability for and make no guarantee of the availability of our website or catalogues. **Drawings are valid only when they have been checked and approved by both partners in accordance with the order acknowledgement.**

Effectiveness at law of the exclusion of liability

If a legal relationship has arisen exclusively from the contents of our website or catalogues without any direct contact between us, this is subject exclusively to Austrian law, with exclusion of the tie-breaker rule. All legal disputes arising shall be subject to the exclusive jurisdiction of the court having competence for A-6890 Feldkirch.

Data protection declaration

We are subject to the provisions of the Austrian Federal Data Protection Act for protection of personal data. We will pass personal information and data relating to persons to other parties only where this is for the purpose of and in relation to contractual orders. Information may be passed to suppliers and subcontractors only where such companies which can offer sufficient guarantees of secure use of the data. We are permitted to pass data to companies directly or indirectly associated with us.

ZIMM Maschinenelemente GmbH + Co KG

General Terms and Conditions

ZIMM Maschinenelemente GmbH + Co KG, Millennium Park 3, 6890 Lustenau/Austria
Phone: 00 43 (0) 55 77/806-0, Fax: 00 43 (0) 55 77/806-8, E-mail: info@zimm.at, www.zimm.at

1. General:

All our contracts are subject to the following terms and conditions unless agreed to the contrary in writing: These terms and conditions are deemed acknowledged and agreed by signing the contract. Any terms and conditions – of any nature – contrary to our general terms and conditions shall be completely inapplicable and invalid, irrespective of the form in which they were brought to our knowledge. Deviations from these general terms and conditions shall be effective only if they have been agreed and confirmed by us in writing. Any agreement to abandon this formal requirement must equally be in writing and signed by both parties. Silence concerning any terms and conditions that deviate from our standard conditions shall not be regarded as consent.

2. Quotations | prices | contractual content

- 2.1. Our quotations remain valid for 60 days after submission, subject to changes in accordance with Point 2.5.
- 2.2. Information in our our catalogues is not contractually binding (see also Point 3).
- 2.3. All our prices are understood to be in Euros and exclusive of VAT. Unless agreed to the contrary, the prices to be invoiced will be our list prices at the time of concluding the contract. These prices are ex works, excluding packaging, freight and/or shipping. Where consignment and delivery have been contractually agreed, prices do not include costs for unloading and transportation to the working site. Risk and rights of use are transferred to our contractual partner at the time of shipment. Delivery is thus always ex works.
- 2.4. **Delivery lead times and dates** are binding provided they have been promised by us in writing. This commitment lapses if our contractual partner requests modification of the order after placing the order or if obstacles outside our control occur, due for instance to force majeure or late delivery by our suppliers.
- 2.5. **Changes to economic circumstances**
If new circumstances arise outside our control, such as materials, taxes, wage rates, strike, war, terrorist attacks, blockades, fire, natural catastrophes or acts of God, we are entitled to amend our quotations and contracts accordingly. This applies particularly in the event that the prices of copper or aluminium rise by more than 10%. In all these cases we are entitled, even after concluding the contract, to amend our prices and due dates.

3. Design and specification

Selection and dimensioning is the customer's responsibility, because we are not familiar with the design criteria such as installation location and type of application. On request we can provide support during selection and specification and make proposals with subassembly drawings and calculations based on your application parameters. This drawing including the parts list is subject to checking by you and approval by us. The drawing checked and approved by you is the basis for production and assembly.

4. Technical modifications during the contract

We are entitled to implement technical modifications after the conclusion of the contract, provided such modifications do not affect the contractual guaranteed performance of the goods.

5. Warranty and liability for defects

- 5.1. The warranty period is 1 year, without exception. Changes to the warranty period require our express commitment in writing.
- 5.2. Trial runs without load and under load in normal operating conditions (according to your design parameters) are necessary to ensure **reliable operation**. We perform our trials under no-load conditions, not under load, but under the customer's installation conditions.

These on-site trial runs are necessary to achieve system alignment and to eliminate any factors which may impair operation. We do not accept any liability for damage that is traceable back to the non-performance of on-site trials under load and representative working conditions. Furthermore we do not accept any liability, except where we have entered into a written assurance to the contrary, for installation of our products in any type of land vehicle, aircraft or water craft

- 5.3. Our contractual partners are obligated to verify goods after delivery and, if necessary, inform us in writing immediately, and in any case no later than within 14 days after delivery, about any **defects**. If no notice of defects is communicated within this time limit, the goods that are delivered are deemed approved and warranty claims –and damage claims shall be excluded.
- 5.4. Our **liability** shall be limited to intentional and severe gross negligence. Any liability for ordinary negligence, for consequential damages, financial loss, loss of profit, loss of interest or for damages resulting from claims of third parties shall be excluded.
- 5.5. **Mechatronic products**
Especially for applications that are installed outdoors, the equipment is subject to environmental conditions to an increased degree. If malfunctions arise, we require documentary evidence of the cause, such as environmental influences or product defects.
- 5.6. **Rectification of defects**
If product defects are accepted, the defective parts must be returned to us without delay, together with documentation of the defect. Your analysis of the cause of the defect is the basis for our laboratory testing and sustained defect prevention measures. The transport costs will be borne by the sender in each case.
6. **Retention of title**
 - 6.1. All goods delivered shall remain our sole property until complete payment of the purchase price.
 - 6.2. Our contractual partner is obliged to treat the goods carefully as long as retention of title applies to the delivered goods. If maintenance and/or inspection work is necessary, our contractual partner shall carry out such work regularly at his own expense.
 - 6.3. Installation or modification of the delivered contractual goods will not result in loss of title to those goods. Our contractual partner is not entitled to resell the delivered contractual goods as long as retention of title remains in force.
7. **Place of performance | Applicable law | Place of jurisdiction**
The exclusive place of performance for all contractual relations is A-6890 Lustenau. Austrian law applies exclusively, with exclusion of the tie-breaker rule.
All legal disputes arising from or relating to the business relations and contracts shall be subject to the exclusive jurisdiction of the court having competence for A-6800 Feldkirch.
8. **Severability clause**
Should any individual provisions in the above general terms and conditions be or become invalid, either in part or in full, this will not affect the validity of the other provisions. The invalid provision will be replaced by a ruling that is as close as possible in economic purpose to the invalid provision in a legally effective and practicable form.

ZIMM Maschinenelemente GmbH + Co KG

**Austria – your local ZIMM representative**

Ing. R. Longhi GmbH + Co
Ringstrasse 1
6923 Lauterach
Phone 0043 (0) 5574 / 799 83
Fax 0043 (0) 5574 / 799 83-15
longhi@longhi.at

Gerhard Bell
Billrothstrasse 32
4050 Traun
Phone 0043 (0) 664 / 422 79 12
Fax 0043 (0) 7229 / 755 46
g.bell@zimm.at

Reinhardt Mayer
Turmgasse 3a
8700 Leoben
Phone 0043 (0) 664 / 183 66 00
Fax 0043 (0) 3842 / 479 51
r.mayer@zimm.at

**Germany – your local ZIMM representative**

Achenbach Antriebstechnik
Am Stubben 7
21244 Buchholz i.d.N.
Phone 0049 (0) 4181 / 38 03 75
Fax 0049 (0) 4181 / 38 03 76
Mobile 0049 (0) 171 / 245 86 71
info@achenbachantriebstechnik.de
www.achenbachantriebstechnik.de

Ing.-Büro Risse
Ketscher Strasse 5a
08141 Reinsdorf/ OT Vielau
Phone 0049 (0) 375 / 60 67 04-0
Fax 0049 (0) 375 / 60 67 04-1
Mobile 0049 (0) 171 / 703 19 40
r.risse@ib-risse.de
www.ib-risse.de

Hagener Fördertechnik GmbH
Koksstrasse 10
58135 Hagen
Phone 0049 (0) 2331 / 94 80-0
Fax 0049 (0) 2331 / 94 80-99
Mobile 0049 (0) 171 / 770 18 65
info@hafoe.de
www.hafoe.de

KW Antriebs- & Automationstechnik GmbH
Koberger Strasse 39
90408 Nuremberg
Phone 0049 (0) 911 / 366 33 69-0
Fax 0049 (0) 911 / 366 33 69-15
info@kw-antriebstechnik.de
www.kw-antriebstechnik.de

Prantner IndustrieVertretung
Braikinbachweg 4
72766 Reutlingen
Phone 0049 (0) 7121 / 748 010
Fax 0049 (0) 7121 / 748 009
post@prantner-iv.de
www.prantner-iv.de

Bretzel GmbH
Antriebs- und Elektrotechnik
Industriestraße 9
65760 Eschborn
Phone 0049 (0) 6196 / 403 19-0
Fax 0049 (0) 6196 / 430 47
info@bretzel-gmbh.de
www.bretzel-gmbh.de

**Switzerland – your local ZIMM representative**

Alfred Imhof AG
Jurastrasse 10
4142 Münchenstein
Phone 0041 (0) 61 / 417 17 17
Fax 0041 (0) 61 / 417 17 00
info@imhof-sew.ch
www.imhof-sew.ch

You can find current addresses at
www.zimm.at

EUROPE



BELGIUM

SEW-EURODRIVE n.v./s.a.
Research Park Hassrode
Evenementenlaan 7
3001 Leuven
Phone 0032 (0) 16 / 386 311
Fax 0032 (0) 16 / 386 336
info@sew-eurodrive.be
www.sew-eurodrive.be



CZECH REPUBLIC



SLOVAKIA

BETZ s.r.o.
Trída Vítězství 68/4
35301 Mariánské Lázně
Phone 0042 (0) 354 / 620 095
Fax 0042 (0) 354 / 627 307
betz@betz.cz
www.betz.cz



DENMARK

ZF Danmark ApS
Taastrupgaardsvej 8-10
2630 Taastrup
Phone 0045 (0) 43 / 436 243
Fax 0045 (0) 43 / 432 643
zfdk@zf.com
www.zf-group.dk



FINLAND

EIE Maskin Oy
PL 80, Asematki 1
10601 Tammisaari
Phone 00358 (0) 19 / 223 91 00
Fax 00358 (0) 19 / 223 91 99
info@eie.fi
www.eie.fi



FRANCE

AGORA Technique S.a.r.l.
8 Bis Rue Volta
Parc Volta
94140 Alfortville
Phone 0033 (0) 1 / 451 843 70
Fax 0033 (0) 1 / 451 843 71
agora@agora-technique.com
www.agora-technique.com



GREAT BRITAIN

HepcoMotion
Lower Moor Business Park
Tiverton Way, Tiverton
Devon, EX16 6TG,
Phone 0044 (0) 1884 / 257 000
Fax 0044 (0) 1884 / 243 500
sales@hepcotion.com
www.hepcotion.com



HUNGARY

IRAMKO Drive Ltd.
Weiss Manfréd út 4.
1211 Budapest
Phone 0036 (0) 1 / 425 73 54
Fax 0036 (0) 1 / 425 73 55
info@iramko.com
www.iramko.com

ECKERLE Industrie Kft.
Dózsa György út 44
6200 Kiskőrös
Phone 0036 (0) 78 / 511 400
Fax 0036 (0) 78 / 511 401
info@hu.eckerle-gruppe.com
www.eckerle-gruppe.com



ITALY

FAVARI TRANSMISSIONI SRL
Via Stephenson 92
20157 Milan
Phone 0039 02 / 357 04 41
Fax 0039 02 / 332 007 36
favari@favari.it
www.favari.it



NETHERLANDS

Groneman BV
Amarilstraat 11, Postbus 24
7550 AA Hengelo (O)
Phone 0031 (0) 74 / 255 11 40
Fax 0031 (0) 74 / 255 11 09
info@groneman.nl
www.groneman.nl



NORWAY

EIE Maskin AS
Tvetenveien 164
0671 Oslo
Phone 0047 (0) 67 / 572 270
Fax 0047 (0) 67 / 572 280
info@elmeko.no
www.elmeko.no



POLAND

INMET-BTH
Ul. Jasna 1-5
43-190 Mikołów
Phone 0048 (0) 32 / 726 19 11
Phone 0048 (0) 32 / 738 19 48
Fax 0048 (0) 32 / 726 18 70
biuro@inmet.com.pl
www.inmetbth.eu

JORDAN matcon Sp. z o.o.

Kijewo 50
63-000 Sroda Wielkopolska
Phone 0048 (0) 61 / 286 07 01
Fax 0048 (0) 61 / 286 07 10
info@jordan-matcon.pl
www.jordan-matcon.pl



PORTUGAL

EQUINOTEC S.A.
Av. Villagarcia de Arosa 1120
4450-300 Matosinhos
Phone 00351 (0) 22 / 935 07 55
Fax 00351 (0) 22 / 935 10 24
info@equinotec.com
www.equinotec.com



ROMANIA

Patrascu & Gane Engineering
Company S.R.L.
Str. Vasile Gherghel, Nr. 18C
Sector 1
011523 Bucharest
Phone 0040 (0) 21 / 222 95 40
Fax 0040 (0) 21 / 222 95 13
office@pge.ro
www.pge.ro



SLOVENIA

LESNIK LENART, d.o.o.
Zgornji Jerjavci 33a
2230 Lenart
Phone 00386 (0) 2 / 729 24 03
Fax 00386 (0) 2 / 729 24 04
info@lesnik-slo.com
www.lesnik-slo.com



SPAIN

TECNOPOWER S.L.
Poligono Industrial Moli dels Frares
Calle C n° 10
08620 Sant Vicenc Dels Horts
Barcelona
Phone 0034 (0) 93 / 656 80 50
Fax 0034 (0) 93 / 656 80 26
tp@tecnopower.es
www.tecnopower.es



SWEDEN

EIE Maskin AB
Box 7
12124 Bandhagen
Phone 0046 (0) 8 / 727 88 00
Fax 0046 (0) 8 / 727 88 99
eie@eie.se
www.eie.se



TURKEY

STAR HIDROPAR
Mak. Parcalari San. LTD. STI.
B Block, No: 1611
Perpa Is Merkezi Kat 11
34384 Okmeydani-ISTANBUL
Phone 0090 (0) 212 / 222 40 84
Fax 0090 (0) 212 / 221 09 99
info@starhidropar.com.tr
www.starhidropar.com.tr

ASIA



CHINA

DPT - Dynamic Power
Transmission Co., Ltd.
Block 5, No 1699, Songze Road
Xujing Industrial Zone, Shanghai
P.R. China
Post Code: 201702
Phone 0086 (0) 21 / 598 839 78
Fax 0086 (0) 21 / 598 839 79
evaguan@zfgta.com.tw
www.gtadtc.com



ISRAEL

Chemlani Technology
31 Haifa Road
28226 Kiryat Ata
Phone 0972 4 / 841 53 95
Fax 0972 4 / 841 53 97
info@chemlani.co.il
www.chemlani.co.il



RUSSIA

Servotechnica ZAO
22, Vyborskaya str.
125130 Moscow
Phone 007 (0) 495 / 797 88 66
Fax 007 (0) 495 / 450 00 43
info@servotechnica.ru
www.servotechnica.ru

Stankoservice-Sokol 000
ul. Tschasowaya 28 Building 4
125315 Moscow
Phone 007 (0) 495 / 225 13 39
Fax 007 (0) 495 / 225 13 39
info@stserv.ru
www.stserv.ru



SOUTH KOREA

JUNGWOO F&B Corp.
118, Nae-dong, Ojeong-gu,
Bucheon-City, Gyeonggi-Do
Republic of Korea, 421-805
Phone 0082 (0) 32 / 683 62 00
Fax 0082 (0) 32 / 684 10 10
biz@jwfnb.co.kr
www.jwfnb.co.kr



TAIWAN

GTA - German Tech Auto Co., Ltd.
No.162, Hsin sheng Road
Taishan Hsiang
Taipei County 243
Taiwan R.O.C
Phone 00886 (0) 2 / 290 309 39
Fax 00886 (0) 2 / 290 306 36
chenray@zfgta.com.tw
www.gtadtc.com

AUSTRALIA and
NEW ZEALAND

AUSTRALIA

T.E.A. Transmissions Pty Ltd.
Tahiti Road
Tiaro, QLD 4650
Phone 0061 (0) 7 / 412 925 33
Fax 0061 (0) 7 / 412 924 37
sales@tea.net.au
www.tea.net.au



NEW ZEALAND

SaecoWilson Ltd.
88 Hastie Ave, Mangere
1122 Auckland
Phone 0064 (0) 9 / 634 75 40
Fax 0064 (0) 9 / 634 75 52
enquires@motion.co.nz
www.saecoprecision.co.nz

NORTH and
SOUTH AMERICA

USA



CANADA

DIEQUA Corporation
180 Covington Drive
Bloomington, Illinois 60108-3105
Phone 001 (0) 630 / 980 11 33
Fax 001 (0) 630 / 980 12 32
info@diequa.com
www.diequa.com



BRAZIL

LF Catelani Equipamentos
Rua Abilio Figueiredo, n92 - sl85
Jundiai - Sao Paulo - Brazil
Zipcode: 13208-140
Phone 0055 (0) 11 / 4497-1735
Fax 0055 (0) 11 / 4497-1735
Lf.equipamentos@gmail.com
www.zimmbrazil.com.br



ZIMM[®] Austria
Screw Jack Systems

ZIMM Maschinenelemente GmbH + Co KG

Millennium Park 3
6890 Lustenau/Austria
Phone: 00 43 (0) 55 77/806-0
Fax: 00 43 (0) 55 77/806-8
E-mail: info@zimm.at
Internet: www.zimm.at