

General function

R+W torque limiting couplings are ball detent style overload couplings. They protect drive and driven mechanical components from damage associated with torque overloads. Backlash free torque transmission is accomplished by a series of steel balls (4) nested in hardened detents (5). See figure 1. Disc springs push against an actuation ring (3) keeping the balls nested. The disengagement torque is adjustable by means of an adjustment ring (1). In the event of an overload, the actuation ring moves axially allowing the balls to come out of the detents separating the drive and driven elements. The movement of the actuation ring can be sensed by means of a mechanical switch or proximity sensor triggering the drive to shut down.

Single-position / Multi-position

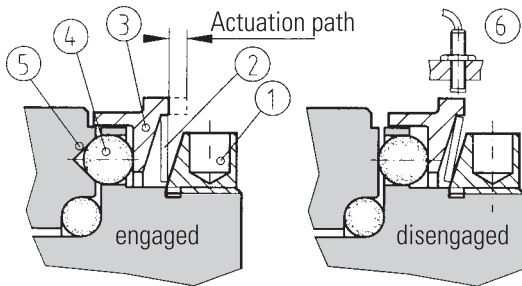

In a torque overload, for the single-position design (standard) and multi-position design, the spring disengages to allow the balls to come out of their detents separating the drive and driven elements. Very low residual spring pressure remains so that the coupling will re-engage once the torque is reduced below the overload setting. See diagram 1 too.

Re-engagement may only be effected at low speed.

Full-disengage

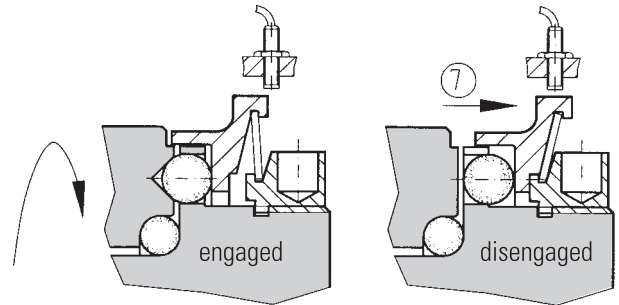

With this design, when a torque overload is detected, the disc spring completely flips over and places no residual spring pressure on the actuation ring. The drive and driven elements are completely separated.

Re-engagement of the coupling is not automatic and must be performed manually (Figure 3).

Full-disengage

Re-engagement of the Full-disengage design

The R+W full-disengage torque limiting coupling can be re-engaged in six different positions or every 60 degrees with low "press-in" force (E). Marks on the actuation ring and body (13) of the coupling must line up and indicate the re-engagement points.

CAUTION: Re-engagement should only be performed when the coupling is still and not rotating!

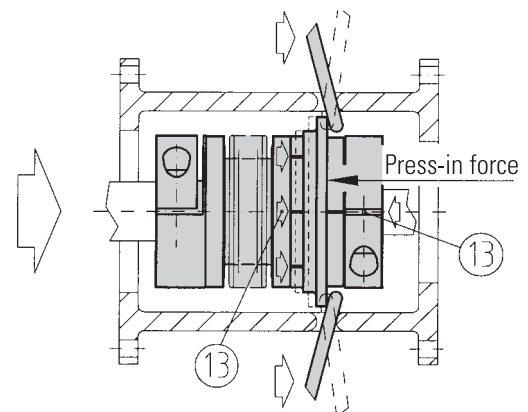

max. misalignments SK 2 - SK 5

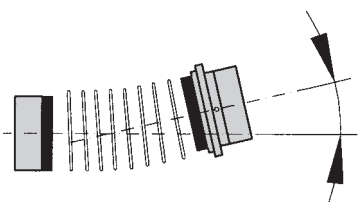

Angular misalignment ΔKw

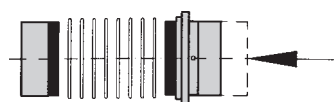

Axial misalignment ΔKa

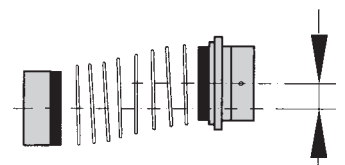

Lateral misalignment ΔKr

CAUTION:

Exact alignment of the R+W metal bellow coupling considerably increases the service life of the coupling. Reducing or eliminating lateral misalignment eliminates the radial loading of the adjacent bearings, increasing service life and reducing heat. For drives running at high speed it is recommended to align the coupling with a dial indicator.

Max. misalignment values see table. Axial misalignment between 1-2 mm (max.).

Mounting-instructions

- All torque limiters are supplied to ISO bore tolerance grade H7. For models SK1 to SK 5 the fit tolerance of the hub/shaft connection must be between 0.01 and 0.05 mm.
- Ensure that the coupling mounts smoothly onto the shaft prior to final installation.
- Lightly oil the shaft prior to installation. Do not use sliding grease, or oils and grease with molybdenum disulfide or other high-pressure additives. Any keyways in the shaft will not affect the functioning of the clamped connection.

Model SK1 / SKP

Model SK1 has an integrated bearing ① for support of the attached component (for example a pulley or sprocket wheel).

Do not exceed the maximum radial force ② (see table)

By centering the load between the dimension (S), addition separate bearing support is not required.

For offset mounting, additional bearings are required .

This is recommended, for example, if the attached component has a very small diameter or the drive element has a very large width.

Depending on the installation situation, ball bearings, needle bearings or bushings may be used.

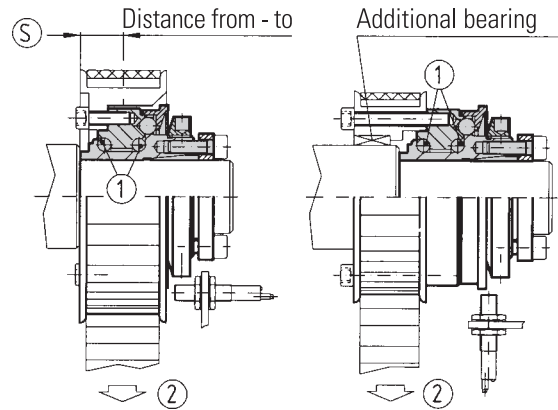

Series max. (N)	2	4,5	10	15	20/30	40/60	80/150	200	300	500	800	1500
Radial load capacity, max. (N)	100	200	500	1400	1800	2300	3000	3500	4500	5600	8000	12000
(S) from-to	5-8	6-10	6-12	7-14	8-18	8-18	12-20	12-22	12-23	12-25	14-34	20-42

Mounting and dismounting: Models SK 1 and SKP

SKP with key

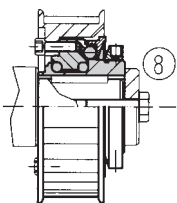

Mounting:

Slide the coupling onto the shaft. Lock it in position, with an end plate (8) for example.

Dismounting:

Remove the end plate and slide the coupling off the shaft using an appropriate tool.

SK 1 with clamping hub

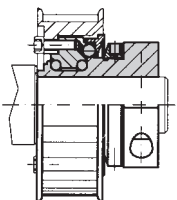

Mounting:

Slide the coupling onto the shaft to the proper axial position. Using a torque wrench tighten the clamp screw to the proper tightening torque as indicated.

Series 2-10 page 7, series 15 and higher see SK 2 page 8.

Dismounting:

Simply loosen the clamp screw and remove the coupling.

SK 1 with tapered bushing

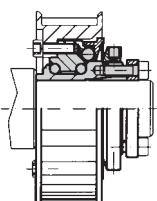

Mounting:

Slide the coupling onto the shaft to the proper axial position. Using a torque wrench, uniformly tighten the clamping screws using a cross-wise tightening pattern until all the clamping screws are evenly tightened to the correct tightening torque as given on page 6. While tightening the coupling may move slightly towards the tapered bushing.

CAUTION: Further tightening of the clamping screws may destroy the tapered bushing connection.

Dismounting:

Loosen the clamping screw. Insert the three jack screws into the taped holes on the tapered segment apply even pressure to remove the tapered segment. Remove the coupling.

Mounting-instructions

SK 2 with clamping hub

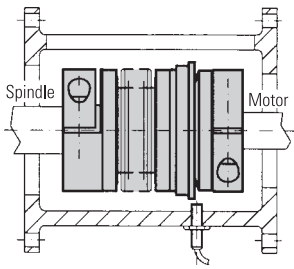

Mounting:

Prior to mounting make sure that the shaft to be connected do not exceed the angular or lateral misalignment limits for the coupling size to be used. This data can be found in the catalog. Slide the coupling on the first shaft end to the proper axial position. Using a torque wrench, tighten the clamp screw to the correct tightening torque as indicated (page 8). Insert the second shaft into the other end of the coupling to the proper axial position. Make sure that the coupling is free of any axial forces before tightening. Tighten the clamp screw as above using a torque wrench.

Dismounting:

Simply loosen the clamp screw and remove the coupling.

SK 3 with tapered bushing

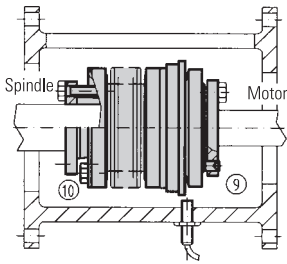

Mounting:

Prior to mounting make sure that the shaft to be connected do not exceed the angular or lateral misalignment limits for the coupling size to be used. This data can be found in the catalog. Slide the coupling onto the first shaft to the proper axial position. Using a torque wrench, uniformly tighten the clamping screws using a cross-wise tightening pattern until all the clamping screws are evenly tightened to the correct tightening torque (see page 9).

Dismounting:

Loosen the clamping screws. Use the three jackscrews conveniently mounted in the taper segment to evenly back out the tapered segment. Remove the coupling.

SK 5 with press-fit tapered clamping hubs

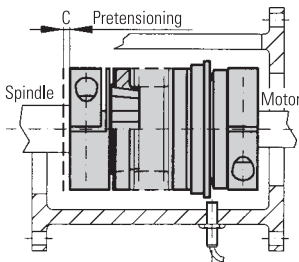

Mounting:

Prior to mounting it is necessary to consider the overall length of the assembled coupling. The press-fit coupling requires a specific pre-tensioning (C) between the two coupling halves to ensure backlash free operation. Mount the "female" coupling half containing the bellows onto the first shaft end to the proper axial position. Using a torque wrench tighten the clamp screw to the proper tightening torque. Mount the "male" coupling segment onto the second shaft end. The proper axial position is when the two couplings come together and coupling is compressed by the proper pre-tension distance (C). See Table 2. When the coupling segment is properly positioned tighten the clamp screw to the proper torque.

Dismounting:

Pull the coupling apart. Simply loosen the clamp screws and remove the coupling from the shaft.

Disengagement torque setting

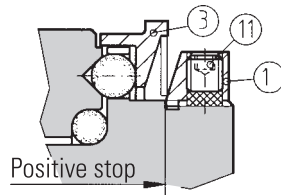
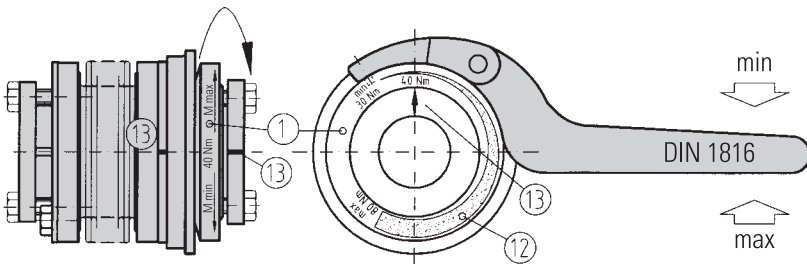

- 1 adjusting nut
- 11 fastening screw
- 12 adjustment range
- 13 marking
- 3 steel actuation ring

With SK 2/5 couplings, the groove of the clamping hub serves as a marking (3)

R+W torque limiters are factory set to the customer specified disengagement torque, which is marked onto the coupling. The adjustment range (min/max) is also marked on the adjustment ring. The customer can adjust the disengagement torque as long as it falls into the range indicated on the adjustment ring.

The adjustment range may not be left during setting.

To adjust the disengagement torque, loosen the locking screws (11) and rotate the adjustment ring using a spanner wrench to the desired new setting. Tighten the locking screws and test the coupling.

CAUTION: R+W torque limiters incorporate disc springs that exhibit a special spring characteristic. It is important to stay in the max-min range of the courding.

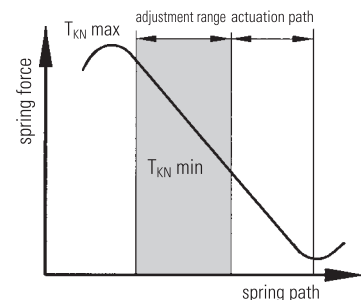

Disengagement behaviour

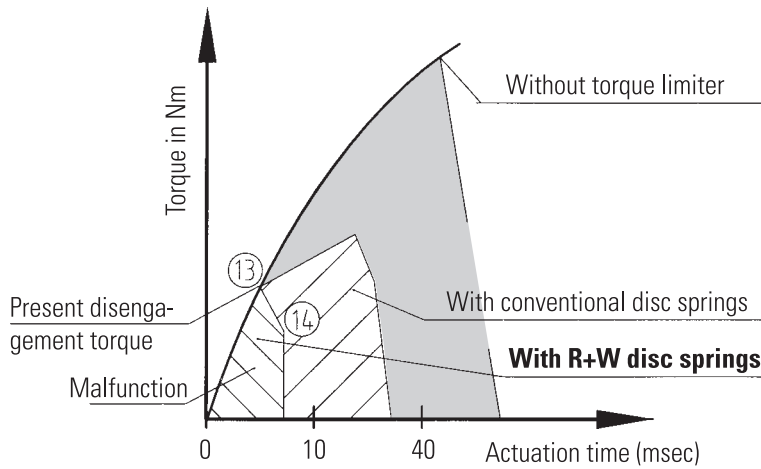

Spring characteristic

Degressive spring characteristic

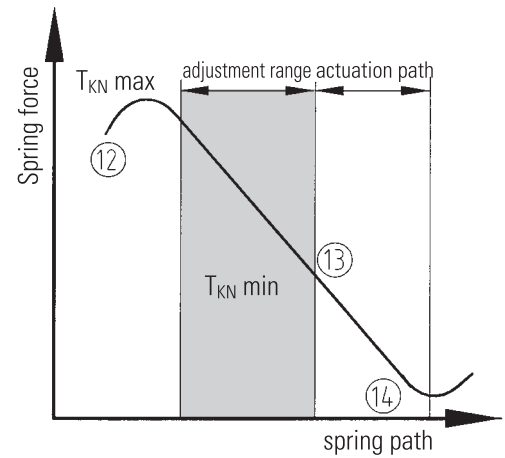

Spring package:

R + W torque limiters function by means of a disc spring with a degressive characteristic (12) developed exclusively for this application. Upon the couplings actuation, this characteristic (13) brings about an immediate drop in the torque (14) and an interruption of the force flux.

The spring force of the disc spring drops to a lower value after the disengagement process.

This advantage guarantees extremely short actuation times (1-3 ms), low wear and very low residual friction (between 2-5 %).

Speed:

The service life of the coupling is essentially determined by the number of rotations after disengagement.

Wear:

No wear occurs during engaged operating condition. In the event of an overload the drive should be stopped through a mechanical limit switch or proximity switch immediately.

Maintenance:

When properly engaged, the torque limiters are wear free, and therefore require no maintenance. The ball detent mechanism within each coupling is permanently lubricated. Prior technical approval is suggested, for applications using our products other than specified.

Seal:

Optional a sealing of the coupling is possible:

Features:

- protection from dirt and liquid contamination
- appropriate for food service and light washdown environments
- clean room applications
- No escape of grease possible

